



MM54C175/MM74C175 Quad D Flip-Flop

General Description

The MM54C175/MM74C175 consists of four positive-edge triggered D type flip-flops implemented with monolithic CMOS technology. Both true and complemented outputs from each flip-flop are externally available. All four flip-flops are controlled by a common clock and a common clear. Information at the D inputs meeting the set-up time requirements is transferred to the Q outputs on the positive-going edge of the clock pulse. The clearing operation, enabled by a negative pulse at Clear input, clears all four Q outputs to logical "0" and Q's to logical "1".

All inputs are protected from static discharge by diode clamps to V_{CC} and GND.

Features

- Wide supply voltage range 3V to 15V
 - Guaranteed noise margin 1.0V
 - High noise immunity
 - Low power TTL compatibility 0.45 V_{CC} (typ.)
- Fan out of 2
driving 74L

Connection Diagram & Truth Table

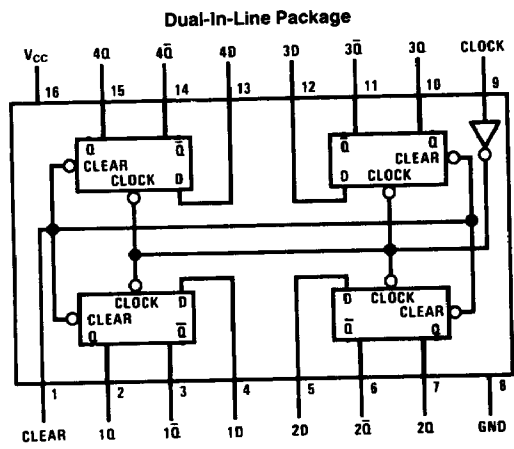

TL/F/5900-1

Order Number MM54C175* or MM74C175*

*Please look into Section 8, Appendix D for availability of various package types.

Each Flip-Flop

Inputs			Outputs	
Clear	Clock	D	Q	Q̄
L	X	X	L	H
H	↑	H	H	L
H	↑	L	L	H
H	H	X	NC	NC
H	L	X	NC	NC

H = High level
 L = Low level
 X = Irrelevant
 ↑ = Transition from low to high level
 NC = No change

Absolute Maximum Ratings (Note 1)

If Military/Aerospace specified devices are required, contact the National Semiconductor Sales Office/Distributors for availability and specifications.

Voltage at Any Pin	-0.3V to $V_{CC} + 0.3V$
Operating Temperature Range	
MM54C175	-55°C to +125°C
MM74C175	-40°C to +85°C

Storage Temperature Range	-65°C to +150°C
Power Dissipation (P_D)	
Dual-In-Line	700 mW
Small Outline	500 mW
Operating V_{CC} Range	3V to 15V
Absolute Maximum V_{CC}	18V
Lead Temperature (Soldering, 10 seconds)	260°C

DC Electrical Characteristics Min/Max limits apply across temperature range unless otherwise specified

Symbol	Parameter	Conditions	Min	Typ	Max	Units
CMOS TO CMOS						
$V_{IN(1)}$	Logical "1" Input Voltage	$V_{CC} = 5V$ $V_{CC} = 10V$	3.5 8.0			V V
$V_{IN(0)}$	Logical "0" Input Voltage	$V_{CC} = 5V$ $V_{CC} = 10V$			1.5 2.0	V V
$V_{OUT(1)}$	Logical "1" Output Voltage	$V_{CC} = 5V, I_O = -10 \mu A$ $V_{CC} = 10V, I_O = -10 \mu A$	4.5 9.0			V V
$V_{OUT(0)}$	Logical "0" Output Voltage	$V_{CC} = 5V, I_O = 10 \mu A$ $V_{CC} = 10V, I_O = 10 \mu A$			0.5 1.0	V V
$I_{IN(1)}$	Logical "1" Input Current	$V_{CC} = 15V, V_{IN} = 15V$		0.005	1.0	μA
$I_{IN(0)}$	Logical "0" Input Current	$V_{CC} = 15V, V_{IN} = 0V$	-1.0	-0.005		μA
I_{CC}	Supply Current	$V_{CC} = 15V$		0.05	300	μA

CMOS/LPTTL INTERFACE

$V_{IN(1)}$	Logical "1" Input Voltage	54C, $V_{CC} = 4.5V$ 74C, $V_{CC} = 4.75V$	$V_{CC} - 1.5$ $V_{CC} - 1.5$			V V
$V_{IN(0)}$	Logical "0" Input Voltage	54C, $V_{CC} = 4.5V$ 74C, $V_{CC} = 4.75V$			0.8 0.8	V V
$V_{OUT(1)}$	Logical "1" Output Voltage	54C, $V_{CC} = 4.5V, I_O = -360 \mu A$ 74C, $V_{CC} = 4.75V, I_O = -360 \mu A$	2.4 2.4			V V
$V_{OUT(0)}$	Logical "0" Output Voltage	54C, $V_{CC} = 4.5V, I_O = 360 \mu A$ 74C, $V_{CC} = 4.75V, I_O = 360 \mu A$			0.4 0.4	V V

OUTPUT DRIVE (See 54C/74C Family Characteristics Data Sheet) (Short Circuit Current)

I_{SOURCE}	Output Source Current (P-Channel)	$V_{CC} = 5V, T_A = 25^\circ C,$ $V_{OUT} = 0V$	-1.75	-3.3		mA
I_{SOURCE}	Output Source Current (P-Channel)	$V_{CC} = 10V, T_A = 25^\circ C,$ $V_{OUT} = 0V$	-8.0	-15		mA
I_{SINK}	Output Sink Current (N-Channel)	$V_{CC} = 5V, T_A = 25^\circ C,$ $V_{OUT} = V_{CC}$	1.75	3.6		mA
I_{SINK}	Output Sink Current (N-Channel)	$V_{CC} = 10V, T_A = 25^\circ C,$ $V_{OUT} = V_{CC}$	8.0	16		mA

Note 1: "Absolute Maximum Ratings" are those values beyond which the safety of the device cannot be guaranteed. Except for "Operating Temperature Range" they are not meant to imply that the devices should be operated at these limits. The table of "Electrical Characteristics" provides conditions for actual device operation.

AC Electrical Characteristics* $T_A = 25^\circ\text{C}$, $C_L = 50\text{ pF}$, unless otherwise noted

Symbol	Parameter	Conditions	Min	Typ	Max	Units
t_{pd}	Propagation Delay Time to a Logical "0" or Logical "1" from Clock to Q or \bar{Q}	$V_{CC} = 5\text{V}$ $V_{CC} = 10\text{V}$		190 75	300 110	ns ns
t_{pd}	Propagation Delay Time to a Logical "0" from Clear to Q	$V_{CC} = 5\text{V}$ $V_{CC} = 10\text{V}$		180 70	300 110	ns ns
t_{pd}	Propagation Delay Time to a Logical "1" from Clear to Q	$V_{CC} = 5\text{V}$ $V_{CC} = 10\text{V}$		230 90	400 150	ns ns
t_S	Time Prior to Clock Pulse that Data Must be Present	$V_{CC} = 5\text{V}$ $V_{CC} = 10\text{V}$	100 40	45 16		ns ns
t_H	Time After Clock Pulse that Data Must be Held	$V_{CC} = 5\text{V}$ $V_{CC} = 10\text{V}$	0 0	-11 -4		ns ns
t_W	Minimum Clock Pulse Width	$V_{CC} = 5.0\text{V}$ $V_{CC} = 10\text{V}$		130 45	250 100	ns ns
t_W	Minimum Clear Pulse Width	$V_{CC} = 5.0\text{V}$ $V_{CC} = 10\text{V}$		120 45	250 100	ns ns
t_r	Maximum Clock Rise Time	$V_{CC} = 5\text{V}$ $V_{CC} = 10\text{V}$	15 5.0	450 125		μs μs
t_f	Maximum Clock Fall Time	$V_{CC} = 5\text{V}$ $V_{CC} = 10\text{V}$	15 5.0	50 50		μs μs
f_{MAX}	Maximum Clock Frequency	$V_{CC} = 5\text{V}$ $V_{CC} = 10\text{V}$	2.0 5.0	3.5 10		MHz MHz
C_{IN}	Input Capacitance	Clear Input (Note 2) Any Other Input		10 5.0		pF pF
C_{PD}	Power Dissipation Capacitance	Per Package (Note 3)		130		pF

*AC Parameters are guaranteed by DC correlated testing.

Note 1: "Absolute Maximum Ratings" are those values beyond which the safety of the device cannot be guaranteed. Except for "Operating Temperature Range" they are not meant to imply that the devices should be operated at these limits. The table of "Electrical Characteristics" provides conditions for actual device operation.

Note 2: Capacitance is guaranteed by periodic testing.

Note 3: C_{PD} determines the no load AC power consumption of any CMOS device. For complete explanation see 54C/74C Family Characteristics Application Note AN-90.

Switching Time Waveforms

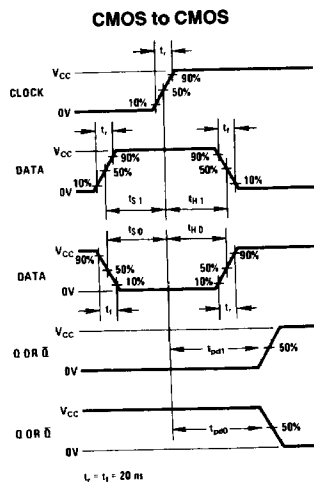

TL/F/5900-6

Logic Diagram

Typical One of Four

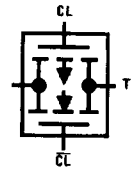
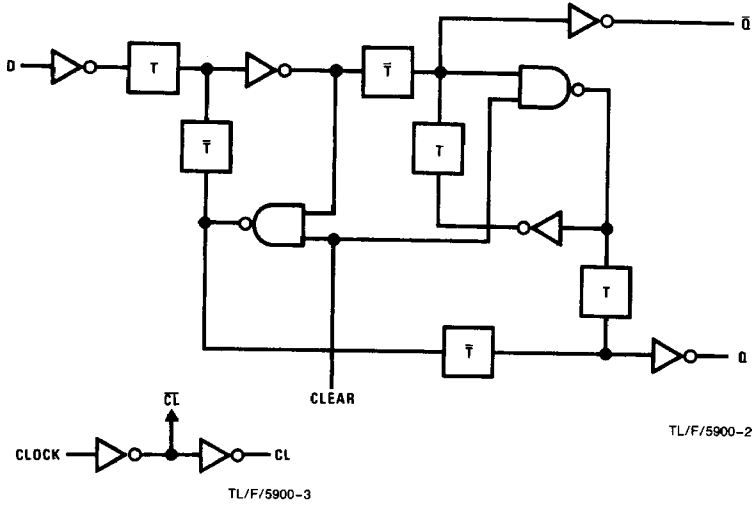

TL/F/5900-4

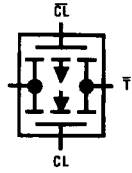

TL/F/5900-5