

Document No.	853-1504
ECN No.	00732
Date of Issue	October 17, 1990
Status	Product Specification
ACL Products	

74AC/ACT11646

Octal transceiver/register with direction pin (3-State)

FEATURES

- Octal bidirectional bus interface
- 3-State buffers
- Independent registers for A and B buses
- Multiplexed real-time and stored data
- Output capability: ± 24 mA
- CMOS (AC) and TTL (ACT) voltage level inputs
- 50 Ω incident wave switching
- Center-pin V_{CC} and ground configuration to minimize high-speed switching noise
- I_{CC} category: MSI

DESCRIPTION

The 74AC/ACT11646 high-performance CMOS devices combine very high speed and high output drive comparable to the most advanced TTL families.

The 74AC/ACT11646 device is an octal transceiver/register featuring non-inverting 3-State bus compatible outputs in both send and receive directions, D-type flip-flops, and control circuitry arranged for multiplexed transmission of data directly from the input bus or from internal

(continued)

PIN CONFIGURATION

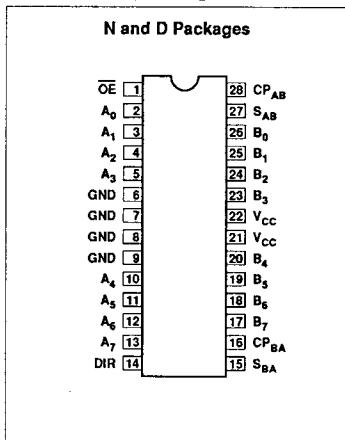

QUICK REFERENCE DATA

SYMBOL	PARAMETER	CONDITIONS		TYPICAL		UNIT
		$T_{amb} = 25^{\circ}\text{C}; \text{GND} = 0\text{V}; V_{CC} = 5.0\text{V}$		AC	ACT	
t_{PLH}/t_{PHL}	Propagation delay A_n to B_n , or B_n to A_n	$C_L = 50\text{pF}$		5.9	7.3	ns
C_{PD}	Power dissipation capacitance per transceiver ¹	$f = 1\text{MHz};$	Enabled	59	63	pF
		$C_L = 50\text{pF}$	Disabled	15	14	
C_{IN}	Input capacitance	$V_I = 0\text{V}$ or V_{CC}		4.5	4.5	pF
C_{IO}	I/O capacitance	$V_O = 0\text{V}$ or V_{CC} ; Disabled		12	12	pF
I_{LATCH}	Latch-up current	Per Jedec JC40.2 Standard 17		500	500	mA
f_{MAX}	Maximum clock frequency, CP_X to A or B	$C_L = 50\text{pF}$		125	125	MHz

Note:

1. C_{PD} is used to determine the dynamic power dissipation (P_D in μW):

$$P_D = C_{PD} \times V_{CC}^2 \times f_I + \sum (C_L \times V_{CC}^2 \times f_O) \text{ where:}$$

f_I = input frequency in MHz, C_L = output load capacitance in pF,

f_O = output frequency in MHz, V_{CC} = supply voltage in V,

$\sum (C_L \times V_{CC}^2 \times f_O)$ = sum of outputs

ORDERING INFORMATION

PACKAGES	TEMPERATURE RANGE	ORDER CODE
28-pin plastic DIP (300mil-wide)	-40°C to +85°C	74AC11646N 74ACT11646N
28-pin plastic SOL (300mil-wide)	-40°C to +85°C	74AC11646D 74ACT11646D

LOGIC SYMBOL

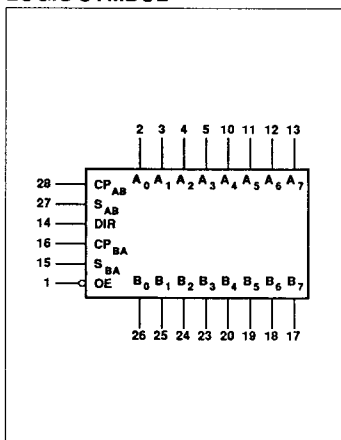

LOGIC SYMBOL (IEEE/IEC)

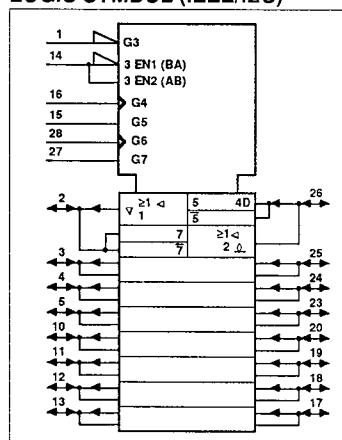

Octal transceiver/register with direction pin (3-State)

74AC/ACT11646

registers. Data on the A or B bus will be clocked into the registers as the appropriate clock pin goes to a High logic level. Output Enable (\overline{OE}) and DIR pins are provided to control the transceiver function. In the transceiver mode, data present at the High-impedance port may be stored in either the A or B register or both.

The Select inputs (S_x) can multiplex stored and real-time (transparent mode) data. The DIR input determines which bus will receive data when the Output Enable is active (Low). In the isolation mode (\overline{OE} is High), A data may be stored in the B register and/or B data may be stored in the A register.

When an output function is disabled, the input function is still enabled and may be used to store and transmit data. Only one of the two buses, A or B, may be driven at a time. Figure 1 demonstrates the four fundamental bus-management functions that can be performed.

PIN DESCRIPTION

PIN NUMBER	SYMBOL	NAME AND FUNCTION
1	\overline{OE}	Output enable input (active Low)
28	CP_{AB}	A-to-B clock input
16	CP_{BA}	B-to-A clock input
27	S_{AB}	A-to-B select input
15	S_{BA}	B-to-A select input
14	DIR	Data flow directional control input
2, 3, 4, 5, 10, 11, 12, 13	$A_0 - A_7$	A side inputs/outputs (3-state)
26, 25, 24, 23, 20, 19, 18, 17	$B_0 - B_7$	B side inputs/outputs (3-state)
6, 7, 8, 9	GND	Ground (0V)
21, 22	V_{CC}	Positive supply voltage

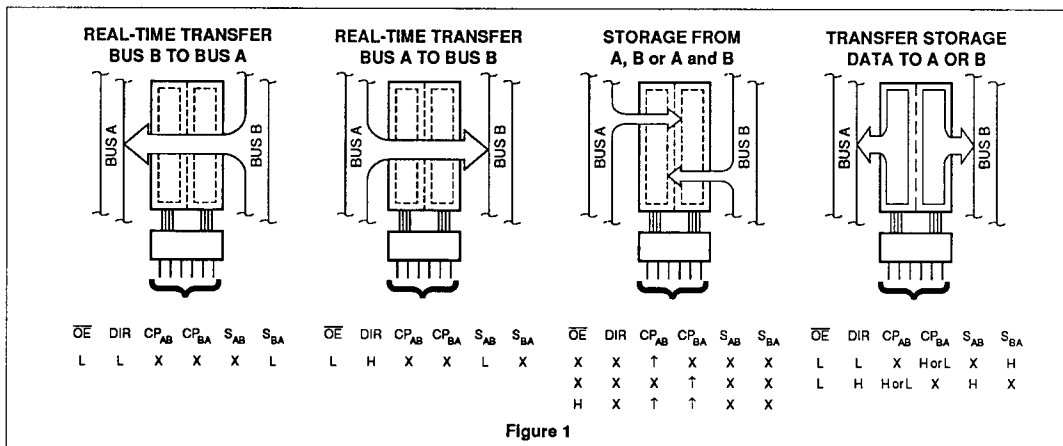

Figure 1

Octal transceiver/register with direction pin (3-State)

74AC/ACT11646

FUNCTION TABLE

INPUTS						DATA I/O*		OPERATING MODE
OE	DIR	CP _{AB}	CP _{BA}	S _{AB}	S _{BA}	A ₀ - A ₇	B ₀ - B ₇	
X	X	↑	X	X	X	Input	un*	Store A, B unspecified*
X	X	X	X	X	X	un*	Input	Store B, A unspecified*
H	X	↑	↑	X	X	Input	Input	Store A and B Data Isolation, hold storage
H	X	H or L	H or L	X	X			
L	L	X	X	X	L	Output	Input	Real time B data to A bus
L	L	X	H or L	X	H			Stored B Data to A Bus
L	H	X	X	L	X	Input	Output	Real time A data to B bus
L	H	H or L	X	H	X			Stored A data to B bus

* The data output functions may be enabled or disabled by various signals at the OE and DIR inputs. Data input functions are always enabled, i.e. data at the bus pins will be stored on every Low-to-High transition of the clock.

un = unspecified

H = Highvoltage level

L = Low voltage level

X = Don't care

↑ = Low-to-High clock transition

LOGIC DIAGRAM

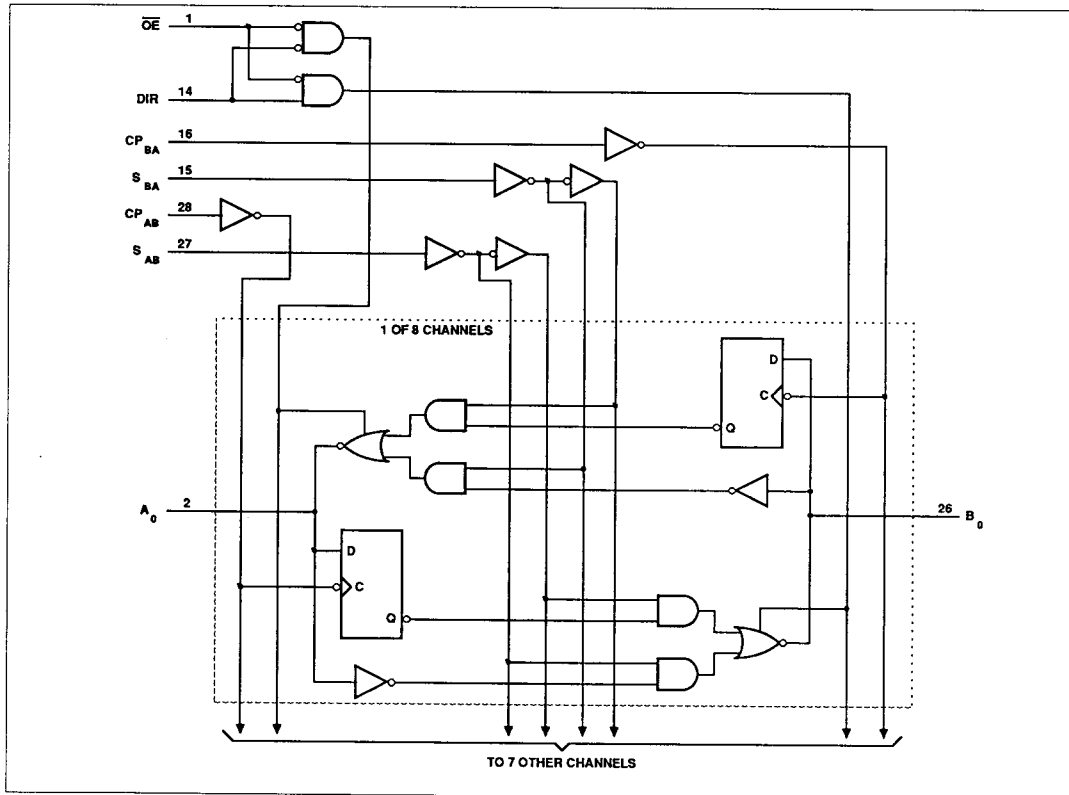

Octal transceiver/register with direction pin (3-State)

74AC/ACT11646

RECOMMENDED OPERATING CONDITIONS

SYMBOL	PARAMETER	74AC11646			74ACT11646			UNIT
		Min	Nom	Max	Min	Nom	Max	
V_{CC}	DC supply voltage	3.0 ¹	5.0	5.5	4.5	5.0	5.5	V
V_I	Input voltage	0		V_{CC}	0		V_{CC}	V
V_O	Output voltage	0		V_{CC}	0		V_{CC}	V
$\Delta t/\Delta v$	Input transition rise or fall rate	0		10	0		10	ns/V
T_{amb}	Operating free-air temperature range	-40		+85	-40		+85	°C

NOTE:

- No electrical or switching characteristics are specified at $V_{CC} < 3V$. Operation between 2V and 3V is not recommended, but within that range, a device output will maintain a previously established logic state.

ABSOLUTE MAXIMUM RATINGS¹

SYMBOL	PARAMETER	TEST CONDITIONS	RATING	UNIT
V_{CC}	DC supply voltage		-0.5 TO +7.0	V
I_{IK} or V_I	DC input diode current ²	$V_I < 0$	-20	mA
		$V_I > V_{CC}$	20	
	DC input voltage		-0.5 to $V_{CC} + 0.5$	V
I_{OK} or V_O	DC output diode current ²	$V_O < 0$	-50	mA
		$V_O > V_{CC}$	50	
	DC output voltage		-0.5 to $V_{CC} + 0.5$	V
I_O	DC output source or sink current per output pin	$V_O = 0$ to V_{CC}	±50	mA
I_{CC} or I_{GND}	DC V_{CC} current		±200	mA
	DC ground current		±200	
T_{STG}	Storage temperature		-65 to 150	°C
P_{TOT}	Power dissipation per package	Above 70°C; derate linearly by 8mW/K	500	mW
	Power dissipation per package Plastic surface mount (SO)	Above 70°C; derate linearly by 8mW/K	400	mW

NOTES:

- Stresses beyond those listed may cause permanent damage to the device. These are stress ratings only and functional operation of the device at these or any other conditions beyond those indicated under "recommended operating conditions" is not implied. Exposure to absolute-maximum-rated conditions for extended periods may affect device reliability.
- The input and output voltage ratings may be exceeded if the input and output current ratings are observed.

Octal transceiver/register with direction pin (3-State)

74AC/ACT11646

DC ELECTRICAL CHARACTERISTICS

SYMBOL	PARAMETER	TEST CONDITIONS	V _{CC} V	74AC11646				74ACT11646				UNIT	
				T _{amb} = +25°C		T _{amb} = -40°C to +85°C		T _{amb} = +25°C		T _{amb} = -40°C to +85°C			
				Min	Max	Min	Max	Min	Max	Min	Max		
V _{IH}	High-level input voltage		3.0	2.10		2.10						V	
			4.5	3.15		3.15		2.0		2.0			
			5.5	3.85		3.85		2.0		2.0			
V _{IL}	Low-level input voltage		3.0		0.90		0.90					V	
			4.5		1.35		1.35		0.8		0.8		
			5.5		1.65		1.65		0.8		0.8		
V _{OH}	High-level output voltage	V _I = V _{IL} or V _{IH}	I _{OH} = -50μA	3.0	2.9		2.9					V	
				4.5	4.4		4.4		4.4		4.4		
				5.5	5.4		5.4		5.4		5.4		
			I _{OH} = -4mA	3.0	2.58		2.48						
				4.5	3.94		3.8		3.94		3.8		
				5.5	4.94		4.8		4.94		4.8		
I _{OH} = -75mA ¹	5.5			3.85				3.85					
V _{OL}	Low-level output voltage	V _I = V _{IL} or V _{IH}	I _{OL} = 50μA	3.0		0.1		0.1				V	
				4.5		0.1		0.1		0.1			0.1
				5.5		0.1		0.1		0.1			0.1
			I _{OL} = 12mA	3.0		0.36		0.44					
				4.5		0.36		0.44		0.36			0.44
				5.5		0.36		0.44		0.36			0.44
I _{OL} = 75mA ¹	5.5				1.65				1.65				
I _I	Input leakage current	V _I = V _{CC} or GND	5.5		±0.1		±1.0		±0.1		±1.0	μA	
I _{OZ}	3-State output off-state current	V _I = V _{IL} or V _{IH} , V _O = V _{CC} or GND	5.5		±0.5		5.0		±0.5		5.0	μA	
I _{CC}	Quiescent supply current	V _I = V _{CC} or GND, I _O = 0mA	5.5		8.0		80		8.0		80	μA	
ΔI _{CC}	Supply current, TTL inputs High ²	One input at 3.4V, other inputs at V _{CC} or GND	5.5						0.9		1.0	mA	

NOTES:

1. Not more than one output should be tested at a time, and the duration of the test should not exceed 10ms.
2. This is the increase in supply current for each input that is at one of the specified TTL voltage levels rather than 0V or V_{CC}.

Octal transceiver/register with direction pin (3-State)

74AC/ACT11646

AC ELECTRICAL CHARACTERISTICS AT 3.3V \pm 0.3V

SYMBOL	PARAMETER	WAVEFORM	74AC11646					UNIT
			T _{amb} = +25°C			T _{amb} = -40°C to +85°C		
			Min	Typ	Max	Min	Max	
f _{MAX}	Maximum clock frequency	1	65	80		65		MHz
t _{PLH} t _{PHL}	Propagation delay CP _{AB} or CP _{BA} to A _n or B _n	1	1.5 1.5	11.8 13.7	15.0 16.8	1.5 1.5	17.0 18.3	ns
t _{PLH} t _{PHL}	Propagation delay A _n or B _n to B _n or A _n	3	1.5 1.5	9.1 10.7	12.1 13.4	1.5 1.5	13.8 14.5	ns
t _{PLH} t _{PHL}	Propagation delay (A _n or B _n High) S _{BA} or S _{AB} to A _n or B _n	2	1.5 1.5	9.8 12.0	12.9 14.5	1.5 1.5	14.4 15.8	ns
t _{PLH} t _{PHL}	Propagation delay (A _n or B _n Low) S _{BA} or S _{AB} to A _n or B _n	3	1.5 1.5	10.7 12.4	13.8 15.0	1.5 1.5	15.4 16.4	ns
t _{PZH} t _{PZL}	Output Enable time OE to A _n or B _n	5	1.5 1.5	13.0 16.1	16.4 20.4	1.5 1.5	18.7 21.8	ns
t _{PZH} t _{PZL}	Output Enable time DIR to A _n or B _n	5	1.5 1.5	13.7 16.8	17.1 21.0	1.5 1.5	19.4 23.6	ns
t _{PHZ} t _{PLZ}	Output disable time OE to A _n or B _n	5	1.5 1.5	7.9 7.2	9.6 8.9	1.5 1.5	10.3 9.6	ns
t _{PHZ} t _{PLZ}	Output disable time DIR to A _n or B _n	5	1.5 1.5	7.9 7.3	9.7 9.1	1.5 1.5	10.5 9.9	ns
t _s	Setup time (High or Low) A _n or B _n to CP _{AB} or CP _{BA}	4	6.5			6.5		ns
t _h	Hold time (High or Low) A _n or B _n to CP _{AB} or CP _{BA}	4	1.0			1.0		ns
t _w	Pulse width (High or Low) CP _{AB} or CP _{BA}	1	7.7			7.7		ns

Octal transceiver/register with direction pin (3-State)

74AC/ACT11646

AC ELECTRICAL CHARACTERISTICS AT 5.0V \pm 0.5V

SYMBOL	PARAMETER	WAVEFORM	74AC11646					UNIT
			$T_{amb} = +25^{\circ}\text{C}$			$T_{amb} = -40^{\circ}\text{C to } +85^{\circ}\text{C}$		
			Min	Typ	Max	Min	Max	
f_{MAX}	Maximum clock frequency	1	100	125		100		MHz
t_{PLH} t_{PHL}	Propagation delay CP _{AB} or CP _{BA} to A _n or B _n	1	1.5 1.5	7.0 8.2	9.7 11.0	1.5 1.5	11.0 12.2	ns
t_{PLH} t_{PHL}	Propagation delay A _n or B _n to B _n or A _n	3	1.5 1.5	5.5 6.3	7.9 8.9	1.5 1.5	8.8 9.8	ns
t_{PLH} t_{PHL}	Propagation delay (A _n or B _n High) S _{BA} or S _{AB} to A _n or B _n	2	1.5 1.5	5.9 7.2	8.4 9.8	1.5 1.5	9.4 10.7	ns
t_{PLH} t_{PHL}	Propagation delay (A _n or B _n Low) S _{BA} or S _{AB} to A _n or B _n	3	1.5 1.5	6.3 7.3	8.9 9.9	1.5 1.5	9.9 11.0	ns
t_{PZH} t_{PZL}	Output Enable time OE to A _n or B _n	5	1.5 1.5	7.8 8.5	10.7 11.9	1.5 1.5	12.0 13.1	ns
t_{PZH} t_{PZL}	Output Enable time DIR to A _n or B _n	5	1.5 1.5	8.4 9.1	11.2 12.3	1.5 1.5	12.6 13.7	ns
t_{PHZ} t_{PLZ}	Output disable time OE to A _n or B _n	5	1.5 1.5	5.9 5.9	8.4 7.7	1.5 1.5	8.9 8.3	ns
t_{PHZ} t_{PLZ}	Output disable time DIR to A _n or B _n	5	1.5 1.5	6.3 5.7	8.2 7.5	1.5 1.5	8.7 8.1	ns
t_s	Setup time (High or Low) A _n or B _n to CP _{AB} or CP _{BA}	4	4.5			4.5		ns
t_h	Hold time (High or Low) A _n or B _n to CP _{AB} or CP _{BA}	4	1.0			1.0		ns
t_w	Pulse width (High or Low) CP _{AB} or CP _{BA}	1	5.0			5.0		ns

Octal transceiver/register with direction pin (3-State)

74AC/ACT11646

AC ELECTRICAL CHARACTERISTICS AT 5.0V ±0.5V

SYMBOL	PARAMETER	WAVEFORM	74ACT11646					UNIT
			T _{amb} = +25°C			T _{amb} = -40°C to +85°C		
			Min	Typ	Max	Min	Max	
f _{MAX}	Maximum clock frequency	1	100	125		100		MHz
t _{PLH} t _{PHL}	Propagation delay CP _{AB} or CP _{BA} to A _n or B _n	1	1.5 1.5	8.8 10.0	11.9 13.4	1.5 1.5	13.5 14.9	ns
t _{PLH} t _{PHL}	Propagation delay A _n or B _n to B _n or A _n	3	1.5 1.5	7.3 7.2	10.1 11.0	1.5 1.5	11.5 12.0	ns
t _{PLH} t _{PHL}	Propagation delay (A _n or B _n High) S _{BA} or S _{AB} to A _n or B _n	2	1.5 1.5	6.7 9.1	10.3 12.1	1.5 1.5	11.5 13.5	ns
t _{PLH} t _{PHL}	Propagation delay (A _n or B _n Low) S _{BA} or S _{AB} to A _n or B _n	3	1.5 1.5	8.0 8.1	10.9 11.9	1.5 1.5	12.4 13.1	ns
t _{PZH} t _{PZL}	Output Enable time OE to A _n or B _n	5	1.5 1.5	7.7 9.2	12.8 13.8	1.5 1.5	14.4 15.3	ns
t _{PZH} t _{PZL}	Output Enable time DIR to A _n or B _n	5	1.5 1.5	10.2 10.9	13.7 14.8	1.5 1.5	15.3 16.5	ns
t _{PHZ} t _{PLZ}	Output disable time OE to A _n or B _n	5	1.5 1.5	8.6 7.8	10.7 9.7	1.5 1.5	11.6 10.6	ns
t _{PHZ} t _{PLZ}	Output disable time DIR to A _n or B _n	5	1.5 1.5	7.9 7.3	10.5 9.5	1.5 1.5	11.3 10.3	ns
t _s	Setup time (High or Low) A _n or B _n to CP _{AB} or CP _{BA}	4		4.5			4.5	ns
t _h	Hold time (High or Low) A _n or B _n to CP _{AB} or CP _{BA}	4		2.5			2.5	ns
t _w	Pulse width (High or Low) CP _{AB} or CP _{BA}	1		5.0			5.0	ns

AC WAVEFORMS

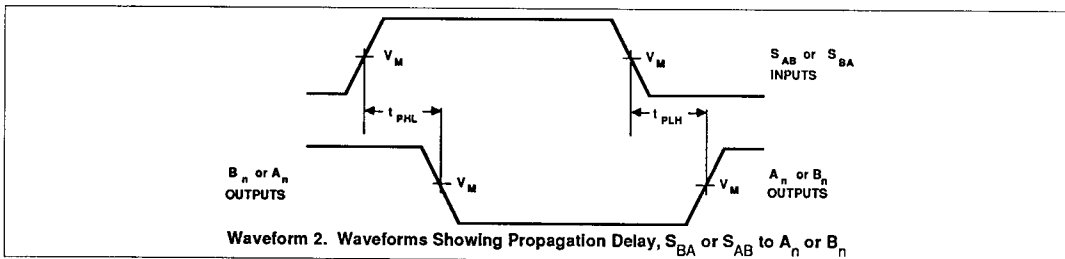
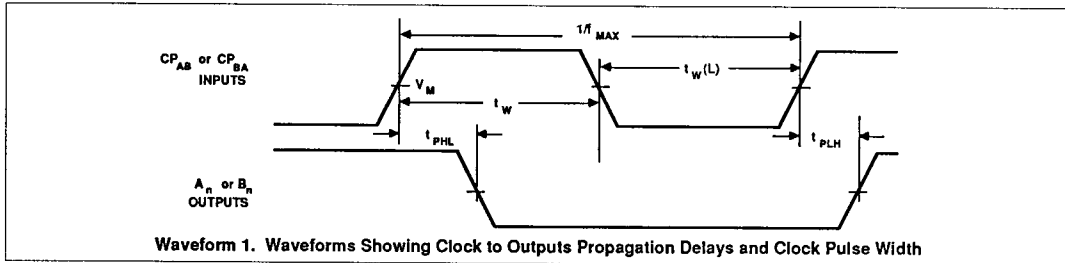

Octal transceiver/register with direction pin (3-State)

74AC/ACT11646

AC WAVEFORMS (Continued)

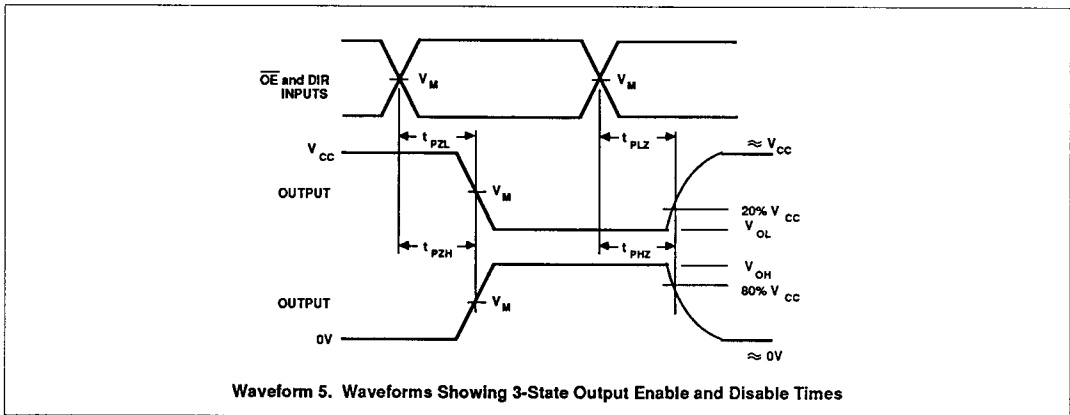
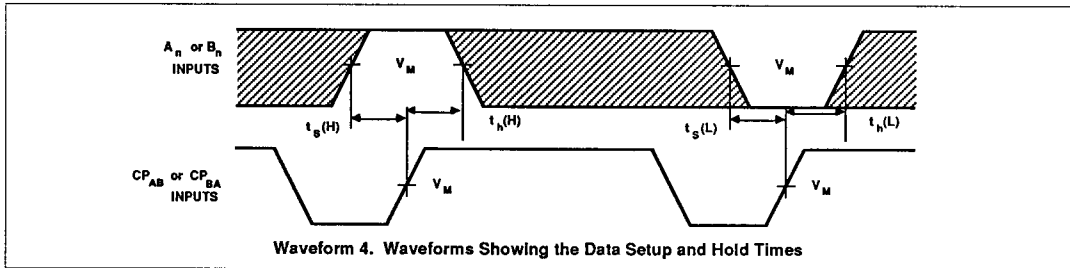
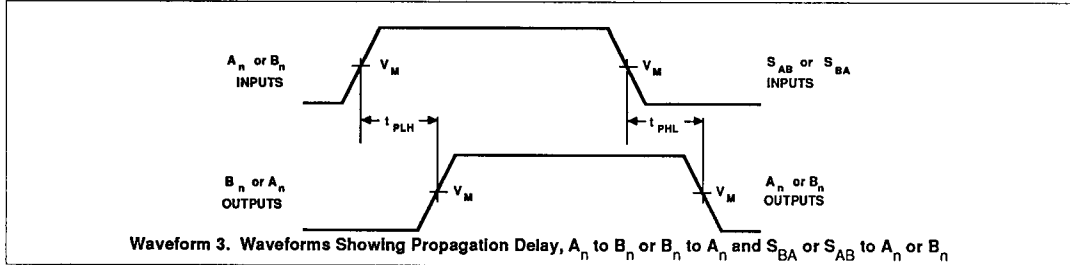

Octal transceiver/register with direction pin (3-State)

74AC/ACT11646

WAVEFORM CONDITIONS

	INPUTS	OUTPUTS
AC	$V_{IN} = \text{GND to } V_{CC},$ $V_M = 50\% V_{CC}$	$V_{OUT} = V_{OL} \text{ to } V_{OH}$ $V_M = 50\% V_{CC}$
ACT	$V_{IN} = \text{GND to } 3.0V,$ $V_M = 1.5V$	

TEST CIRCUIT

