

A-21-03

RJ24, RJ26 SERIES

MIL-R-22097 Qualified

Multi-Turn

Cermet Trimming

Potentiometers

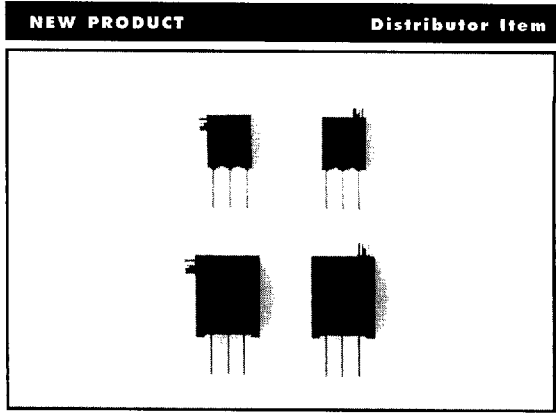

FEATURES/BENEFITS

- Teflon Rotor
- ISO 9000 Certified Factory

STYLES

RJ24	3/8" Square, Top or Side Adjustment
RJ26	1/4" Square, Top or Side Adjustment

ELECTRICAL

Standard Resistance Range, Ohms	10 to 1Meg	
Standard Resistance Tolerance	±10%	
Input Voltage, Maximum	200V dc or rms not to exceed power rating	
Slider Current, Maximum	100mA or within rated power, whichever is less	
Power Rating, Watts	RJ24:	0.5 at 85°C derating to 0 at 150°C
	RJ26:	0.25 at 85°C derating to 0 at 150°C
End Resistance, Maximum	2 Ohms or 2%	
Actual Electrical Travel, Turns, Nominal	RJ24:	20
	RJ26:	11
Dielectric Strength	RJ24:	900V rms
	RJ26:	600V rms
Insulation Resistance, Minimum	1,000 Megohms	
Resolution	Essentially infinite	
Contact Resistance Variation, Maximum	3% or 3 Ohms, whichever is greater	

Specifications subject to change without notice.

ENVIRONMENTAL (PER MIL-R-22097)

Seal	85°C Fluorinert® (No Leaks)
Temperature Coefficient, Maximum	F = ±100ppm/°C C = 250ppm/°C
Operating Temperature Range	-65°C to +150°C
Thermal Shock	5 cycles, -65°C to +150°C (1% ΔR _T , 1% ΔVR) MIL-STD-202, Method 107, Test Condition B
Moisture Resistance	Ten 24 hour cycles (1% ΔR _T , IR 100 Megohms Min.) Method 106, 96 hours
Shock, 6ms Sawtooth	100G's (1% ΔR _T , 1% ΔVR) MIL-STD-202, Method 213, Test Condition I
Vibration	20G's, 10 to 2,000 Hz (1% ΔR _T , 1% ΔVR) MIL-STD-202, Method 204, Test Condition D
High Temperature Exposure	250 hours at 150°C (2% ΔR _T , 2% ΔVR)
Rotational Life	200 cycles (2% ΔR _T)
Load Life at 0.5 Watts	1,000 hours at 85°C (2% ΔR _T) MIL-STD-202, Method 108, Test Condition D
Resistance to Solder Heat	350°C for 3 sec. (1% ΔR _T)

Fluorinert® is a registered trademark of 3M Company.

MECHANICAL

Mechanical Stops	Clutch action, both ends
Torque, Operating, Maximum	RJ24: 5 oz.-in. (0.035 N-m) RJ26: 3 oz.-in. (0.021 N-m)
Weight, Maximum	RJ24: .04 oz. (1.3 grams) RJ26: .014 oz. (.6 grams)

ORDERING INFORMATION

Model RJ24:

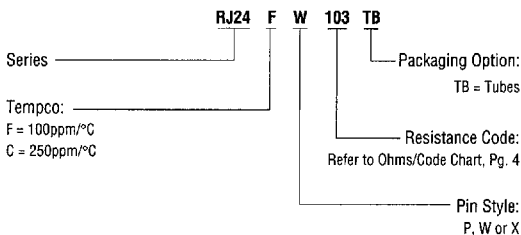

Model RJ26:

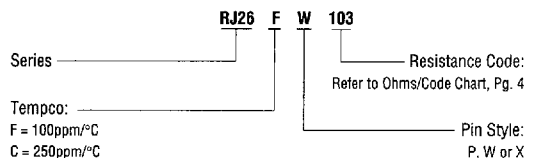

TOP ADJUSTMENT - RJ24FW

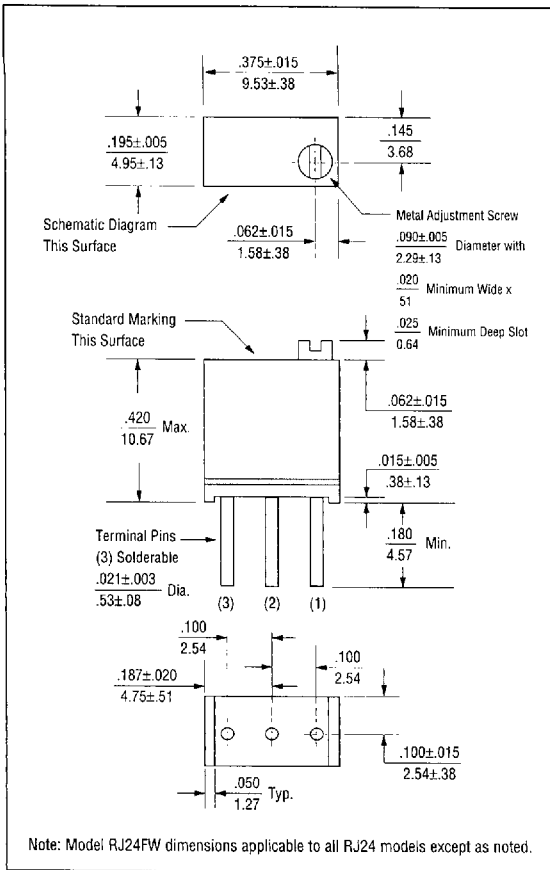

SIDE ADJUSTMENT - RJ24FX

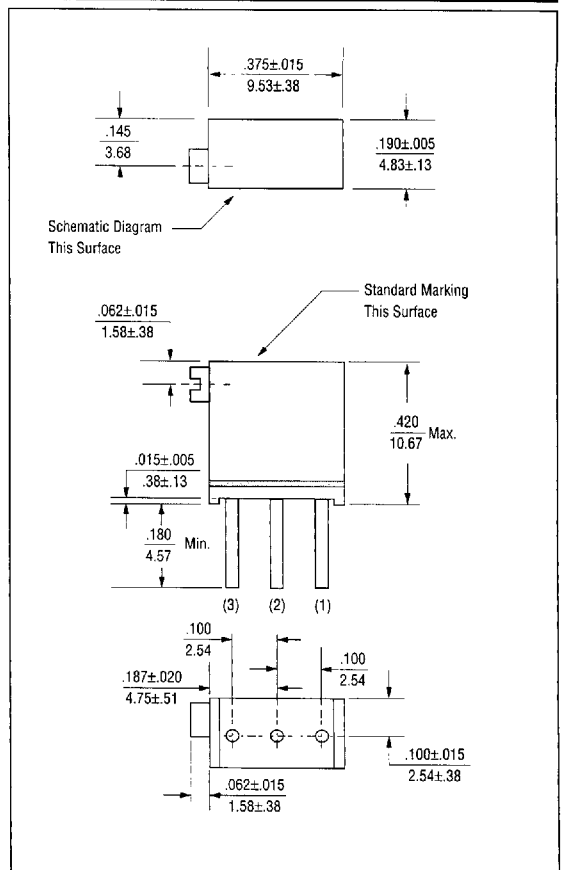

SIDE ADJUSTMENT - RJ24FP

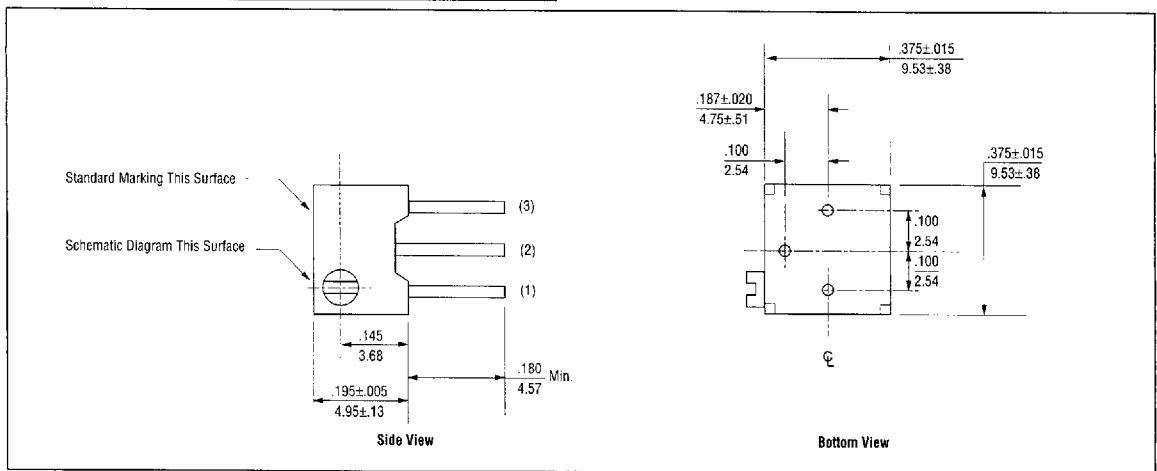

TOP ADJUSTMENT - RJ26FW

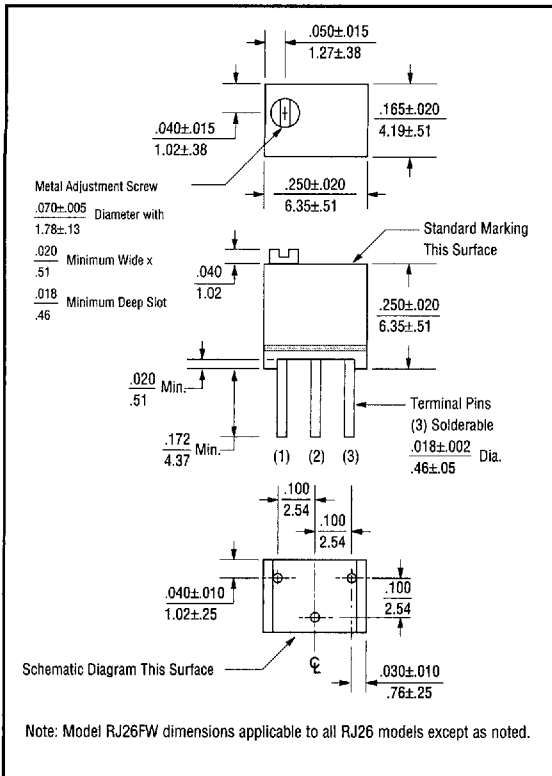

SIDE ADJUSTMENT - RJ26FX

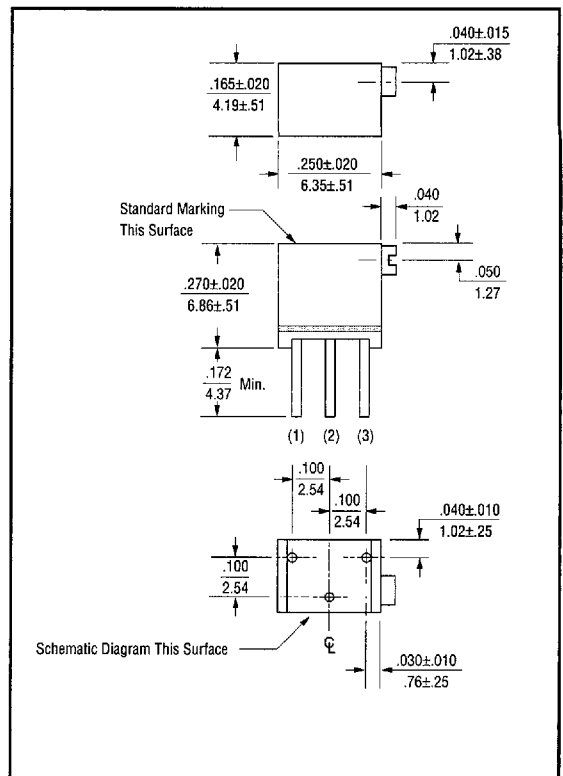

SIDE ADJUSTMENT - RJ26FP

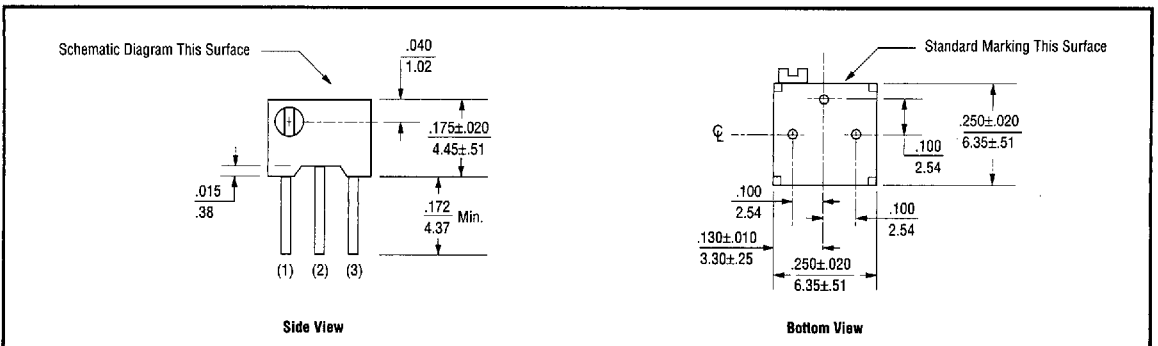

CIRCUIT DIAGRAM

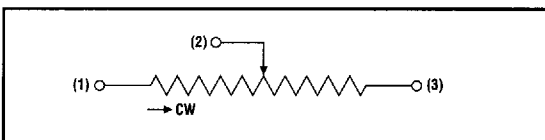

NOTES

Metric equivalents, based on 1 inch = 25.4mm and are provided for general information only.

Tolerances unless otherwise specified:
 Linear = $\pm .005$ inches (.13mm)
 Angular = ± 2 degrees

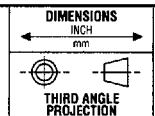

STANDARD RESISTANCE VALUES

Ohms	10	20	50	100	200	500	1,000	2,000	5,000	10,000	20,000	25,000	50,000	100,000	250,000	500,000	1,000,000
Code	100	200	500	101	201	501	102	202	502	103	203	253	503	104	254	504	105

PACKAGING FOR MODEL RJ24**Standard:** Boxes

Capacity, Units = 100

Option: Tubes

All Units oriented with #1 pin to same side

Pin Style		P	W	X
Magazine: Width	=	0.57"	0.28"	0.28"
Height	=	0.66"	0.93"	0.93"
Length	=	20.9"	20.6"	24.4
Capacity, Units	=	100	100	100

PACKAGING FOR MODEL RJ26**Standard:** Tubes

All Units oriented with #1 pin to same side

Pin Style		P,W	X
Magazine: Width	=	0.38"	0.38"
Height	=	0.62"	0.62"
Length	=	14.5"	16.9"
Capacity, Units	=	50	50