

CKTS	DIM A	DIM B
2	.200/5.08	.100/2.54
3	.300/7.62	.200/5.08
4	.400/10.16	.300/7.62
5	.500/12.70	.400/10.16
6	.600/15.24	.500/12.70
7	.700/17.78	.600/15.24
8	.800/20.32	.700/17.78
9	.900/22.86	.800/20.32
10	1.000/25.40	.900/22.86
11	1.100/27.94	1.000/25.40
12	1.200/30.48	1.100/27.94
13	1.300/33.02	1.200/30.48
14	1.400/35.56	1.300/33.02
15	1.500/38.10	1.400/35.56
16	1.600/40.64	1.500/38.10
17	1.700/43.18	1.600/40.64
18	1.800/45.72	1.700/43.18
19	1.900/48.26	1.800/45.72
20	2.000/50.80	1.900/48.26
21	2.100/53.34	2.000/50.80
22	2.200/55.88	2.100/53.34
23	2.300/58.42	2.200/55.88
24	2.400/60.96	2.300/58.42
25	2.500/63.50	2.400/60.96
26	2.600/66.04	2.500/63.50
27	2.700/68.58	2.600/66.04
28	2.800/71.12	2.700/68.58
29	2.900/73.66	2.800/71.12
30	3.000/76.20	2.900/73.66
31	3.100/78.74	3.000/76.20
32	3.200/81.28	3.100/78.74
33	3.300/83.82	3.200/81.28
34	3.400/86.36	3.300/83.82
35	3.500/88.90	3.400/86.36
36	3.600/91.44	3.500/88.90

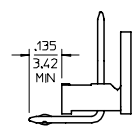

KINKED PIN OPTION
SEE NOTE 5

- NOTES:
- MATERIAL: GLASS FILLED NYLON, 94V-0, COLOR: BLACK
 - FINISH:
 - (154) *OVERALL TIN: .000100/0.00254 MIN. OVER .000050/0.00127 MIN NICKEL.
 - (208) SELECT GOLD: .000015/0.00038 MIN. *SELECT TIN: .000100/0.00254 MIN. OVERALL NICKEL UNDERPLATE: .000050/0.00127 MIN.
 - (228) SELECT GOLD: .000030/0.00076 MIN. *SELECT TIN: .000100/0.00254 MIN. OVERALL NICKEL UNDERPLATE: .000050/0.00127 MIN.
 - *THE PRIMARY SHIPPING CARTON WILL BE LABELED "COMPLIANT TO ROHS DIRECTIVE 2002/95/EC AND ELV ANNEX II OF DIRECTIVE 2000/53/EC". CARTONS WITHOUT THIS LABEL MAY CONTAIN PRODUCT WITH TIN-LEAD PLATING
 - PRODUCT SPECIFICATION: PS-10-07.
 - PACKAGING INFORMATION: SEE TABLES
 - KINK PIN SPECIFICATION: SEE SMES-42003
 - HEADERS ARE NOT STACKABLE ON .100/2.54 CENTERS.
 - SOLDERABILITY PER SMES-152.
 - PIN PUSH OUT FORCE: 3 LBS, MIN.

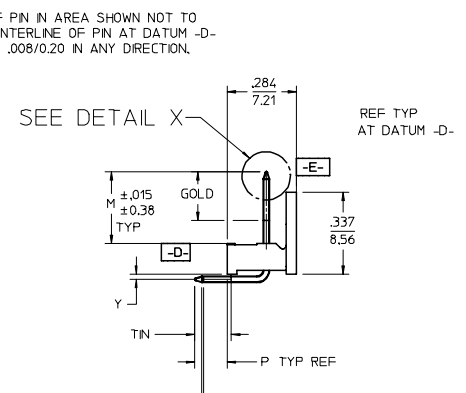
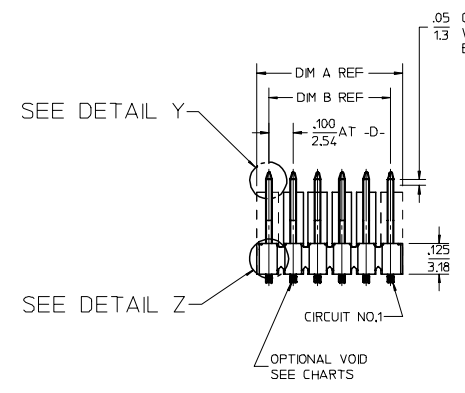
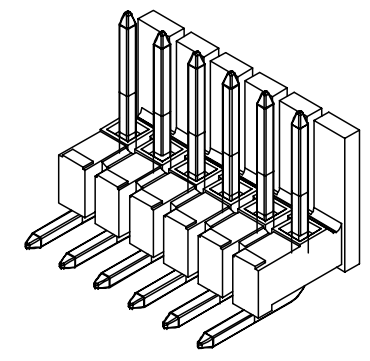
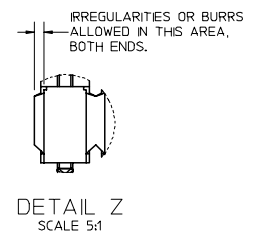
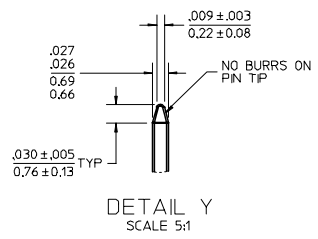
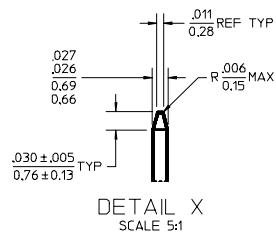
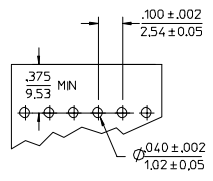

RECOMMENDED PC BOARD LAYOUT

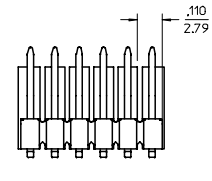

REMOVED BACK WALL OPTION
SEE CHART

UPDATE P/N EC NO: UCP2006-2979 DRWN:PRIDDER 2006/06/13 CHKD:ADERR 2006/06/20 APPR:FSM:TH 2006/06/28	QUALITY SYMBOLS =0 =0	GENERAL TOLERANCES (UNLESS SPECIFIED)		DIMENSION STYLE IN/MM		SCALE	DESIGN UNITS	THIRD ANGLE PROJECTION	
		mm	INCH	DRAWN BY	DATE	2:1	INCH		
REV	DESCRIPTION	4 PLACES	± ---	± ---	JSCHAFFER	2003/09/23	TITLE .100 POLARIZING BREAKAWAY HEADER ASSY OPPOSITE BEND	SHEET NO. 1 OF 4	
		3 PLACES	± ---	± .010	CHECKED BY	DATE			
		2 PLACES	± 0.25	± .014	KSAMIEC	2003/09/23			
		1 PLACE	± 0.36	± ---	APPROVED BY	DATE			
		ANGULAR	± 1/2°		MARGULIS	2003/09/23	MOLEX MOLEX INCORPORATED		
		DRAFT WHERE APPLICABLE MUST REMAIN WITHIN DIMENSIONS		MATERIAL NO. SEE CHART		DOCUMENT NO. SD-42624-001			
		SIZE B	THIS DRAWING CONTAINS INFORMATION THAT IS PROPRIETARY TO MOLEX INCORPORATED AND SHOULD NOT BE USED WITHOUT WRITTEN PERMISSION						

A-42624-0002/0036

HEADER NUMBER:	41410
PIN NUMBER:	42663-CKA154
PIN LENGTH: L	.705 / (17.91)
MATING LENGTH: M	.295 / (7.49)
GOLD POINT: G	N/A
PIN HEIGHT: Y	.022 / (0.56)
PC TAIL LENGTH: P	.120 / (3.05)
TIN: T	OVERALL
CKTS:	2-36
KINKS:	NO
REMOVED BACKWALLS:	NO
VOIDED CKTS:	NONE
PACKAGING:	BULK 40873-0056

CKTS	MATERIAL NUMBER	ENG NUMBER	CKTS	MATERIAL NUMBER	ENG NUMBER
02		A-42624-0002	20		A-42624-0020
03		A-42624-0003	21		A-42624-0021
04		A-42624-0004	22		A-42624-0022
05		A-42624-0005	23		A-42624-0023
06		A-42624-0006	24		A-42624-0024
07		A-42624-0007	25		A-42624-0025
08		A-42624-0008	26		A-42624-0026
09		A-42624-0009	27		A-42624-0027
10		A-42624-0010	28		A-42624-0028
11		A-42624-0011	29		A-42624-0029
12		A-42624-0012	30		A-42624-0030
13		A-42624-0013	31		A-42624-0031
14		A-42624-0014	32		A-42624-0032
15		A-42624-0015	33		A-42624-0033
16		A-42624-0016	34		A-42624-0034
17		A-42624-0017	35		A-42624-0035
18		A-42624-0018	36	22-25-2367	A-42624-0036
19		A-42624-0019			

A-42624-0107/0141

HEADER NUMBER:	41410
PIN NUMBER:	42663-CAN154
PIN LENGTH: L	.720 / (18.29)
MATING LENGTH: M	.295 / (7.49)
GOLD POINT: G	N/A
PIN HEIGHT: Y	.022 / (0.56)
PC TAIL LENGTH: P	.135 / (3.43)
TIN: T	OVERALL
CKTS:	2-36
KINKS:	YES
REMOVED BACKWALLS:	NO
VOIDED CKTS:	NONE
PACKAGING:	BULK 40873-0056

CKTS	MATERIAL NUMBER	ENG NUMBER	CKTS	MATERIAL NUMBER	ENG NUMBER
02	42624-0107	A-42624-0107	20	42624-0125	A-42624-0125
03	42624-0108	A-42624-0108	21	42624-0126	A-42624-0126
04	42624-0109	A-42624-0109	22	42624-0127	A-42624-0127
05	42624-0110	A-42624-0110	23	42624-0128	A-42624-0128
06	42624-0111	A-42624-0111	24	42624-0129	A-42624-0129
07	42624-0112	A-42624-0112	25	42624-0130	A-42624-0130
08	42624-0113	A-42624-0113	26	42624-0131	A-42624-0131
09	42624-0114	A-42624-0114	27	42624-0132	A-42624-0132
10	42624-0115	A-42624-0115	28	42624-0133	A-42624-0133
11	42624-0116	A-42624-0116	29	42624-0134	A-42624-0134
12	42624-0117	A-42624-0117	30	42624-0135	A-42624-0135
13	42624-0118	A-42624-0118	31	42624-0136	A-42624-0136
14	42624-0119	A-42624-0119	32	42624-0137	A-42624-0137
15	42624-0120	A-42624-0120	33	42624-0138	A-42624-0138
16	42624-0121	A-42624-0121	34	42624-0139	A-42624-0139
17	42624-0122	A-42624-0122	35	42624-0140	A-42624-0140
18	42624-0123	A-42624-0123	36	42624-0141	A-42624-0141
19	42624-0124	A-42624-0124			

REV:	<u>ECR/ECN INFORMATION:</u>	<u>TITLE:</u>	<u>SHEET No.</u>
J3	EC No: UCP2006-2979	.100 POLARIZING BREAKAWAY HEADER ASSY OPPOSITE BEND	- 2 -
	DATE: 2006-06-12		
<u>DOCUMENT NUMBER:</u>	<u>CREATED / REVISED BY:</u>	<u>CHECKED BY:</u>	<u>APPROVED BY:</u>
SD-42624-001	PRIDDER	ADERR	FSMITH

A-42624-0281/0312					
HEADER NUMBER:		41410			
PIN NUMBER:		42663-CKB208 (20MI GOLD)			
PIN LENGTH: L		.705 / (17.91)			
MATING LENGTH: M		.295 / (7.49)			
GOLD POINT: G		.180 / (4.57)			
PIN HEIGHT: Y		.022 / (0.56)			
PC TAIL LENGTH: P		.120 / (3.05)			
TIN: T		.135 / (3.43)			
CKTS:		5-36			
KINKS:		NO			
REMOVED BACKWALLS:		NO			
VOIDED CKTS:		5,16			
PACKAGING:		BULK 40873-0056			
CKTS	MATERIAL NUMBER	ENG NUMBER	CKTS	MATERIAL NUMBER	ENG NUMBER
02			20		A-42624-0296
03			21		A-42624-0297
04			22		A-42624-0298
05		A-42624-0281	23		A-42624-0299
06		A-42624-0282	24	22-25-2246	A-42624-0300
07		A-42624-0283	25		A-42624-0301
08		A-42624-0284	26		A-42624-0302
09		A-42624-0285	27		A-42624-0303
10		A-42624-0286	28		A-42624-0304
11		A-42624-0287	29		A-42624-0305
12		A-42624-0288	30		A-42624-0306
13		A-42624-0289	31		A-42624-0307
14		A-42624-0290	32		A-42624-0308
15		A-42624-0291	33		A-42624-0309
16		A-42624-0292	34		A-42624-0310
17		A-42624-0293	35		A-42624-0311
18		A-42624-0294	36		A-42624-0312
19		A-42624-0295			

A- 42624-0313/0346					
HEADER NUMBER:		41410			
PIN NUMBER:		42663-CAN154			
PIN LENGTH: L		.720 / (17.29)			
MATING LENGTH: M		.295 / (7.49)			
GOLD POINT: G		N/A			
PIN HEIGHT: Y		.022 / (0.56)			
PC TAIL LENGTH: P		.135 / (3.43)			
TIN: T		OVERALL			
CKTS:		3-36			
KINKS:		YES			
REMOVED BACKWALLS:		YES			
VOIDED CKTS:		NONE			
PACKAGING:		BULK 40873-0056			
CKTS	MATERIAL NUMBER	ENG NUMBER	CKTS	MATERIAL NUMBER	ENG NUMBER
02			20	42624-0330	A-42624-0330
03	42624-0313	A-42624-0313	21	42624-0331	A-42624-0331
04	42624-0314	A-42624-0314	22	42624-0332	A-42624-0332
05	42624-0315	A-42624-0315	23	42624-0333	A-42624-0333
06	42624-0316	A-42624-0316	24	42624-0334	A-42624-0334
07	42624-0317	A-42624-0317	25	42624-0335	A-42624-0335
08	42624-0318	A-42624-0318	26	42624-0336	A-42624-0336
09	42624-0319	A-42624-0319	27	42624-0337	A-42624-0337
10	42624-0320	A-42624-0320	28	42624-0338	A-42624-0338
11	42624-0321	A-42624-0321	29	42624-0339	A-42624-0339
12	42624-0322	A-42624-0322	30	42624-0340	A-42624-0340
13	42624-0323	A-42624-0323	31	42624-0341	A-42624-0341
14	42624-0324	A-42624-0324	32	42624-0342	A-42624-0342
15	42624-0325	A-42624-0325	33	42624-0343	A-42624-0343
16	42624-0326	A-42624-0326	34	42624-0344	A-42624-0344
17	42624-0327	A-42624-0327	35	42624-0345	A-42624-0345
18	42624-0328	A-42624-0328	36	42624-0346	A-42624-0346
19	42624-0329	A-42624-0329			

J3	<u>ECR/ECN INFORMATION:</u>		<u>TITLE:</u> .100 POLARIZING BREAKAWAY HEADER ASSY OPPOSITE BEND	<u>SHEET No.</u> - 3 -
	EC No: UCP2006-2979			
	DATE: 2006-06-12			
<u>DOCUMENT NUMBER:</u> SD-42624-001		<u>CREATED / REVISED BY:</u> PRIDDER	<u>CHECKED BY:</u> ADERR	<u>APPROVED BY:</u> FSMITH

A-42624-0377/0411					
HEADER NUMBER:		41410			
PIN NUMBER:		42663-CNA154			
PIN LENGTH: L		.720 / (18.29)			
MATING LENGTH: M		.295 / (7.49)			
GOLD POINT: G		N/A			
PIN HEIGHT: Y		.022 / (0.56)			
PC TAIL LENGTH: P		.135 / (3.43)			
TIN: T		OVERALL			
CKTS:		2-36			
KINKS:		NO			
REMOVED BACKWALLS:		NO			
VOIDED CKTS:		NONE			
PACKAGING:		BULK 40873-0056			
CKTS	MATERIAL NUMBER	ENG NUMBER	CKTS	MATERIAL NUMBER	ENG NUMBER
02	42624-0377	A-42624-0377	20	A-42624-0395	42624-0395
03	42624-0378	A-42624-0378	21	A-42624-0396	42624-0396
04	42624-0379	A-42624-0379	22	A-42624-0397	42624-0397
05	42624-0380	A-42624-0380	23	A-42624-0398	42624-0398
06	42624-0381	A-42624-0381	24	A-42624-0399	42624-0399
07	42624-0382	A-42624-0382	25	A-42624-0400	42624-0400
08	42624-0383	A-42624-0383	26	A-42624-0401	42624-0401
09	42624-0384	A-42624-0384	27	A-42624-0402	42624-0402
10	42624-0385	A-42624-0385	28	A-42624-0403	42624-0403
11	42624-0386	A-42624-0386	29	A-42624-0404	42624-0404
12	42624-0387	A-42624-0387	30	A-42624-0405	42624-0405
13	42624-0388	A-42624-0388	31	A-42624-0406	42624-0406
14	42624-0389	A-42624-0389	32	A-42624-0407	42624-0407
15	42624-0390	A-42624-0390	33	A-42624-0408	42624-0408
16	42624-0391	A-42624-0391	34	A-42624-0409	42624-0409
17	42624-0392	A-42624-0392	35	A-42624-0410	42624-0410
18	42624-0393	A-42624-0393	36	A-42624-0411	42624-0411
19	42624-0394	A-42624-0394			

A-42624-0412/0446					
HEADER NUMBER:		41410			
PIN NUMBER:		42663-CNA122			
PIN LENGTH: L		.720 / (18.29)			
MATING LENGTH: M		.295 / (7.49)			
GOLD POINT: G		N/A			
PIN HEIGHT: Y		.022 / (0.56)			
PC TAIL LENGTH: P		.135 / (3.43)			
TIN: T		OVERALL			
CKTS:		2-36			
KINKS:		NO			
REMOVED BACKWALLS:		NO			
VOIDED CKTS:		NONE			
PACKAGING:		BULK 40873-0056			
CKTS	MATERIAL NUMBER	ENG NUMBER	CKTS	MATERIAL NUMBER	ENG NUMBER
02	42624-0412	A-42624-0412	20	42624-0430	A-42624-0430
03	42624-0413	A-42624-0413	21	42624-0431	A-42624-0431
04	42624-0414	A-42624-0414	22	42624-0432	A-42624-0432
05	42624-0415	A-42624-0415	23	42624-0433	A-42624-0433
06	42624-0416	A-42624-0416	24	42624-0434	A-42624-0434
07	42624-0417	A-42624-0417	25	42624-0435	A-42624-0435
08	42624-0418	A-42624-0418	26	42624-0436	A-42624-0436
09	42624-0419	A-42624-0419	27	42624-0437	A-42624-0437
10	42624-0420	A-42624-0420	28	42624-0438	A-42624-0438
11	42624-0421	A-42624-0421	29	42624-0439	A-42624-0439
12	42624-0422	A-42624-0422	30	42624-0440	A-42624-0440
13	42624-0423	A-42624-0423	31	42624-0441	A-42624-0441
14	42624-0424	A-42624-0424	32	42624-0442	A-42624-0442
15	42624-0425	A-42624-0425	33	42624-0443	A-42624-0443
16	42624-0426	A-42624-0426	34	42624-0444	A-42624-0444
17	42624-0427	A-42624-0427	35	42624-0445	A-42624-0445
18	42624-0428	A-42624-0428	36	42624-0446	A-42624-0446
19	42624-0429	A-42624-0429			

REV: J3	<u>ECR/ECN INFORMATION:</u>		<u>TITLE:</u> .100 POLARIZING BREAKAWAY HEADER ASSY OPPOSITE BEND	<u>SHEET No.</u> - 4 -
	<u>EC No:</u> UCP2006-2979			
	<u>DATE:</u> 2006-06-12			
<u>DOCUMENT NUMBER:</u> SD-42624-001		<u>CREATED / REVISED BY:</u> PRIDDER	<u>CHECKED BY:</u> ADERR	<u>APPROVED BY:</u> FSMITH