

1N3305
thru
1N3350

50 WATT SILICON ZENER DIODES

Available in Voltages from 6.8 V thru 200 V

FEATURES:

- ZENER VOLTAGE 6.8 TO 200 V
- LOW ZENER IMPEDANCE
- HIGHLY RELIABLE AND RUGGED
- HERMETICALLY SEALED
- MATTE TIN PLATED
- CUSTOM DESIGNS AVAILABLE ~ CONSULT FACTORY

POLARITY: Standard polarity anode to case. Reverse polarity (cathode to case) indicated by suffix R. (EX. 1N3305RB).

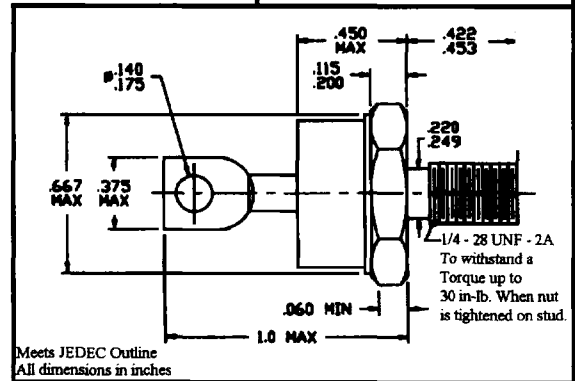
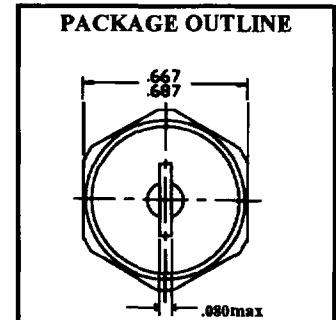
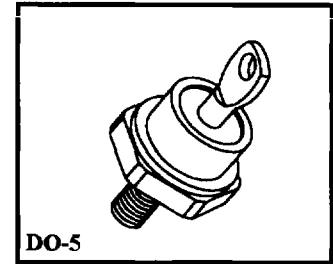

MAXIMUM RATINGS:

Junction and Storage Temperatures -65°C to $+175^{\circ}\text{C}$
 DC Power Dissipation: 50 Watts
 Power Derating: 0.5 W° above 75°C
 Forward Voltage @ 10 A: 1.5 Volts Max

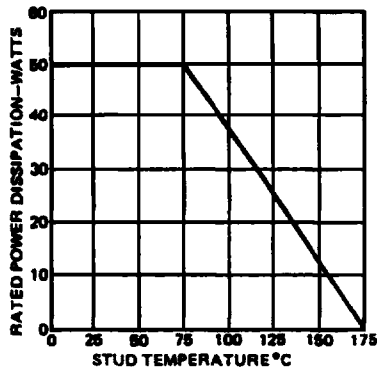

Power Derating Curve

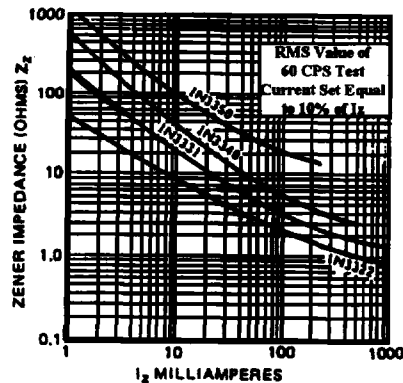

Typical Zener Impedance vs. Zener Current

NEW ENGLAND SEMICONDUCTOR

1N3305 thru 1N3350

TYPE [^]	NOMINAL ZENER VOLTAGE $V_Z @ I_{ZT}$ VOLTS	MAX. DYNAMIC IMPEDANCE				MAX. REVERSE LEAKAGE			MAX. ZENER CURRENT I_{ZM} mA	TYP. TEMP COEFF. I_{ZT} %/°C
		$Z_{ZT} @ I_{ZT}$		$Z_{ZK} @ I_{ZK}$		$I_R @ V_{R1}^*$	V_{R2}^{**}			
		OHMS	mA	OHMS	mA	μA	VOLTS	VOLTS		
1N3305	6.8	0.20	1850	70	5	150	4.5	4.3	6600	.040
1N3306	7.5	0.30	1700	70	5	75	5.0	4.7	5900	.045
1N3307	8.2	0.40	1500	70	5	50	5.4	5.2	5200	.048
1N3308	9.1	0.50	1370	70	5	25	6.1	5.7	4800	.051
1N3309	10.0	0.60	1200	80	5	10	6.7	6.3	4300	.055
1N3310	11.0	0.80	1100	80	5	5	8.4	8.0	3900	.060
1N3311	12.0	1.00	1000	80	5	5	9.1	8.6	3600	.065
1N3312	13.0	1.10	960	80	5	5	9.9	9.4	3300	.065
1N3313	14.0	1.20	890	80	5	5	10.6	10.1	3000	.070
1N3314	15.0	1.40	830	80	5	5	11.4	10.8	2800	.070
1N3315	16.0	1.60	780	80	5	5	12.2	11.5	2650	.070
1N3316	17.0	1.80	740	80	5	5	13.0	12.2	2500	.075
1N3317	18.0	2.00	700	80	5	5	13.7	13.0	2300	.075
1N3318	19.0	2.20	660	80	5	5	14.4	13.7	2200	.075
1N3319	20.0	2.40	630	80	5	5	15.2	14.4	2100	.075
1N3320	22.0	2.50	570	80	5	5	16.7	15.8	1900	.080
1N3321	24.0	2.60	520	80	5	5	18.2	17.3	1750	.080
1N3322	25.0	2.70	500	90	5	5	19.0	18.0	1550	.080
1N3323	27.0	2.80	460	90	5	5	20.6	19.4	1500	.085
1N3324	30.0	3.00	420	90	5	5	22.8	21.6	1400	.085
1N3325	33.0	3.20	380	90	5	5	25.1	23.8	1300	.085
1N3326	36.0	3.50	350	90	5	5	27.4	25.9	1150	.085
1N3327	39.0	4.00	320	90	5	5	29.7	28.1	1050	.090
1N3328	43.0	4.50	290	90	5	5	32.7	31.0	975	.090
1N3329	45.0	4.50	280	100	5	5	34.2	32.4	930	.090
1N3330	47.0	5.00	270	100	5	5	35.8	33.8	880	.090
1N3331	50.0	5.00	250	100	5	5	38.0	36.0	830	.090
1N3332	51.0	5.20	245	100	5	5	38.8	36.7	810	.090
1N3333	52.0	5.50	240	100	5	5	39.5	37.4	790	.090
1N3334	56.0	6.00	220	110	5	5	42.6	40.3	740	.090
1N3335	62.0	7.00	200	120	5	5	47.1	44.6	660	.090
1N3336	68.0	8.00	180	140	5	5	51.7	49.0	600	.090
1N3337	75.0	9.00	170	150	5	5	56.0	54.0	540	.090
1N3338	82.0	11.00	150	160	5	5	62.2	59.0	490	.090
1N3339	91.0	15.00	140	180	5	5	69.2	65.5	420	.090
1N3340	100.0	20.00	120	200	5	5	76.0	72.0	400	.090
1N3341	105.0	25.00	120	210	5	5	79.8	75.6	380	.095
1N3342	110.0	30.00	110	220	5	5	83.6	79.2	365	.095
1N3343	120.0	40.00	100	240	5	5	91.2	86.4	335	.095
1N3344	130.0	50.00	95	270	5	5	98.8	93.6	310	.095
1N3345	140.0	60.00	90	325	5	5	106.4	100.8	290	.095
1N3346	150.0	75.00	85	400	5	5	114.0	108.0	270	.095
1N3347	160.0	80.00	80	450	5	5	121.6	115.2	250	.095
1N3348	175.0	85.00	70	500	5	5	133.0	126.0	230	.095
1N3349	180.0	90.00	68	525	5	5	136.8	129.6	220	.095
1N3350	200.0	100.0	65	600	5	5	152.0	144.0	200	.100

[^]Suffix 'A' indicates ± 10% tolerance.

** V_{R2} - test voltage for I_R

[^]Suffix 'B' indicates ± 5% tolerance.

* V_{R1} - test voltage for I_R

[^]No suffix indicates ± 20% tolerance.

No I_R specified for this device