



L6919C

5 BIT PROGRAMMABLE DUAL-PHASE CONTROLLER WITH DYNAMIC VID MANAGEMENT

- 2 PHASE OPERATION WITH SYNCHRONOUS RECTIFIER CONTROL
- ULTRA FAST LOAD TRANSIENT RESPONSE
- INTEGRATED HIGH CURRENT GATE DRIVERS: UP TO 2A GATE CURRENT
- TTL-COMPATIBLE 5 BIT PROGRAMMABLE OUTPUT FROM 0.800V TO 1.550V WITH 25mV STEPS
- DYNAMIC VID MANAGEMENT
- 0.6% OUTPUT VOLTAGE ACCURACY
- 10% ACTIVE CURRENT SHARING ACCURACY
- DIGITAL 2048 STEP SOFT-START
- OVERVOLTAGE PROTECTION
- OVERCURRENT PROTECTION REALIZED USING THE LOWER MOSFET'S $R_{DS(ON)}$ OR A SENSE RESISTOR
- OSCILLATOR EXTERNALLY ADJUSTABLE AND INTERNALLY FIXED AT 200kHz
- POWER GOOD OUTPUT AND INHIBIT FUNCTION
- REMOTE SENSE BUFFER
- PACKAGE: SO-28

APPLICATIONS

- POWER SUPPLY FOR SERVERS AND WORKSTATIONS
- POWER SUPPLY FOR HIGH CURRENT MICROPROCESSORS
- DISTRIBUTED POWER SUPPLY

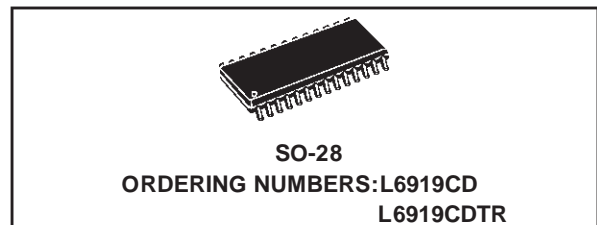

DESCRIPTION

The device is a power supply controller specifically designed to provide a high performance DC/DC conversion for high current microprocessors. The device implements a dual-phase step-down controller with a 180° phase-shift between each phase. A precise 5-bit digital to analog converter (DAC) allows adjusting the output voltage from 0.800V to 1.550V with 25mV binary steps managing On-The-Fly VID code changes.

The high precision internal reference assures the selected output voltage to be within $\pm 0.6\%$. The high peak current gate drive affords to have fast switching to the external power mos providing low switching losses.

The device assures a fast protection against load over current and load over/under voltage. An internal crowbar is provided turning on the low side mosfet if an over-voltage is detected. In case of over-current, the system works in Constant Current mode.

BLOCK DIAGRAM

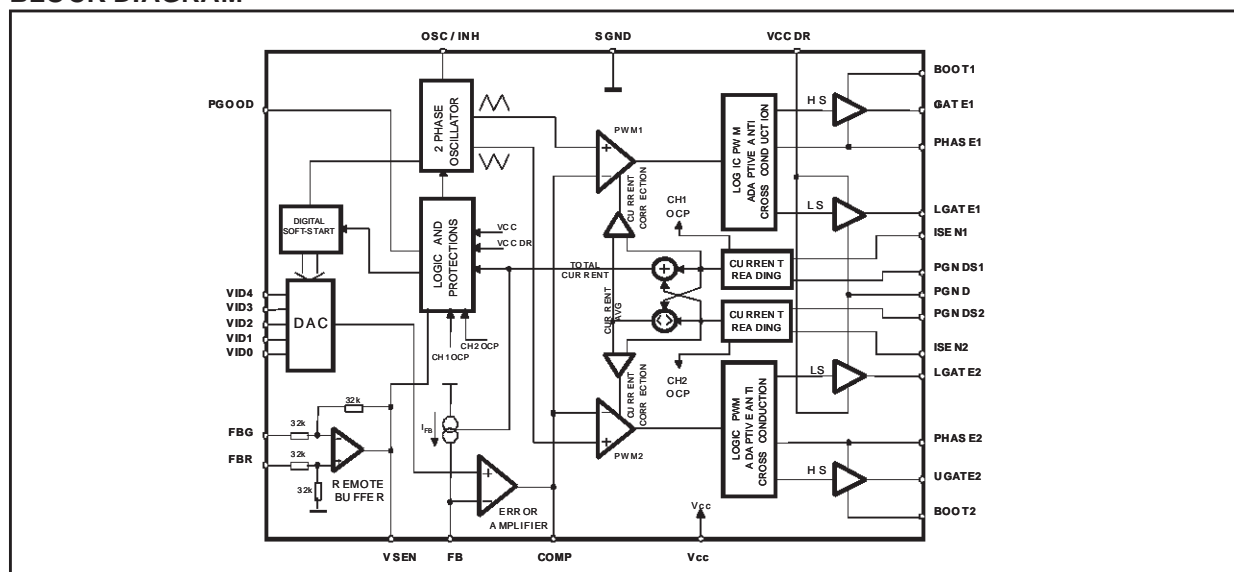

L6919C

ABSOLUTE MAXIMUM RATINGS

Symbol	Parameter	Value	Unit
V_{CC}, V_{CCDR}	to PGND	15	V
$V_{BOOT}-V_{PHASE}$	Boot Voltage	15	V
$V_{UGATE1}-V_{PHASE1}$ $V_{UGATE2}-V_{PHASE2}$		15	V
	LGATE1, PHASE1, LGATE2, PHASE2 to PGND	-0.3 to $V_{CC}+0.3$	V
	VID0 to VID4	-0.3 to 5	V
	All other pins to PGND	-0.3 to 7	V
V_{phase}	Sustainable Peak Voltage $t < 20ns @ 600kHz$	26	V

THERMAL DATA

Symbol	Parameter	Value	Unit
$R_{th j-amb}$	Thermal Resistance Junction to Ambient	60	°C/W
T_{max}	Maximum junction temperature	150	°C
$T_{storage}$	Storage temperature range	-40 to 150	°C
T_j	Junction Temperature Range	0 to 125	°C
P_{MAX}	Max power dissipation at $T_{amb} = 25^{\circ}C$	2	W

PIN CONNECTION

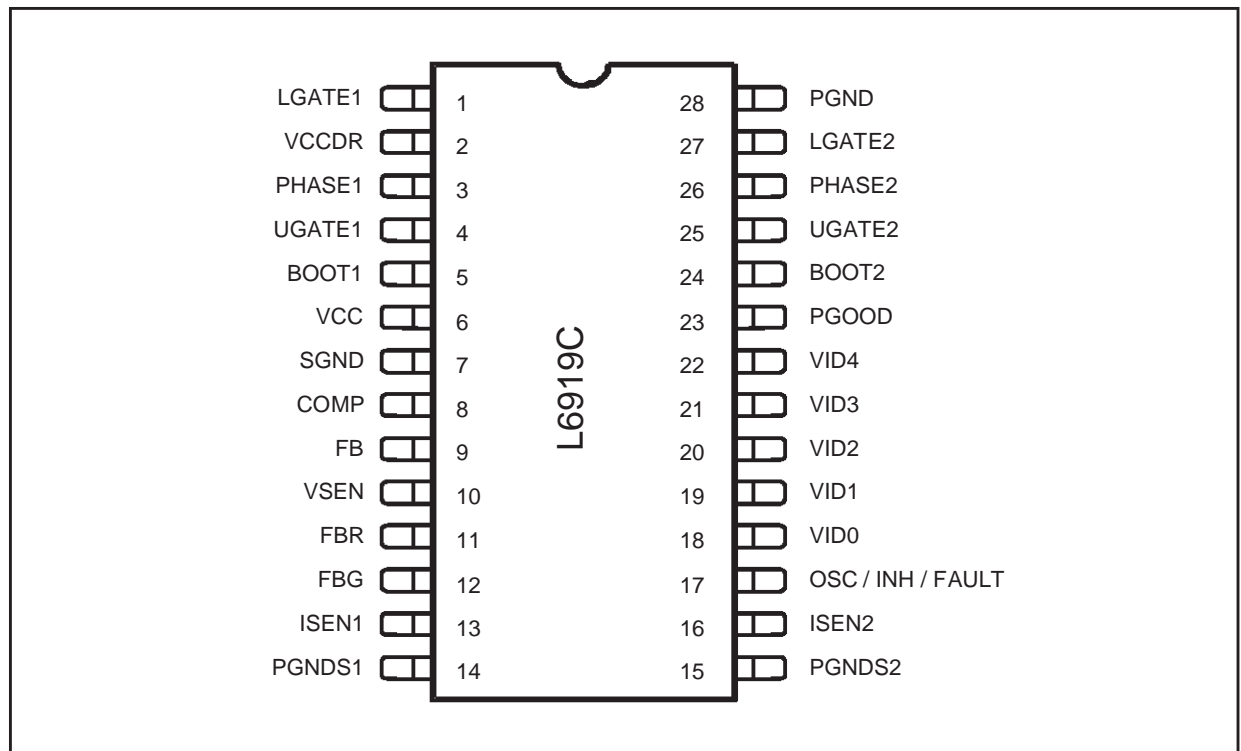

ELECTRICAL CHARACTERISTICS

$V_{CC} = 12V \pm 10\%$, $T_J = 0$ to 70°C unless otherwise specified

Symbol	Parameter	Test Condition	Min	Typ	Max	Unit
V_{CC} SUPPLY CURRENT						
I _{CC}	V _{CC} supply current	HGATE _x and LGATE _x open V _{CCDR} =V _{BOOT} =12V	7.5	10	12.5	mA
I _{CCDR}	V _{CCDR} supply current	LGATE _x open; V _{CCDR} =12V	2	3	4	mA
I _{BOOTx}	Boot supply current	HGATE _x open; PHASE _x to PGND V _{CC} =V _{BOOT} =12V	0.5	1	1.5	mA
POWER-ON						
	Turn-On V _{CC} threshold	V _{CC} Rising; V _{CCDR} =5V	8	9.2	10.4	V
	Turn-Off V _{CC} threshold	V _{CC} Falling; V _{CCDR} =5V	6.5	7.5	8.5	V
	Turn-On V _{CCDR} Threshold	V _{CCDR} Rising V _{CC} =12V	4.2	4.4	4.6	V
	Turn-Off V _{CCDR} Threshold	V _{CCDR} Falling V _{CC} =12V	4.0	4.2	4.4	V
OSCILLATOR/INHIBIT/FAULT						
f _{OSC}	Initial Accuracy	OSC = OPEN OSC = OPEN; T _J =0°C to 125°C	185 180	200	215 220	kHz kHz
f _{OSC,ROSC}	Total Accuracy	R _T to GND=74kΩ	360	400	440	kHz
INH	Inhibit threshold	I _{SINK} =5mA	0.5			V
d _{MAX}	Maximum duty cycle	OSC = OPEN; I _{FB} = 0	75	80		%
		OSC = OPEN; I _{FB} = 60μA	38	46		%
ΔV _{osc}	Ramp Amplitude		1.8	2	2.2	V
FAULT	Voltage at pin OSC	OVP or UVP Active	4.75	5.0	5.25	V
REFERENCE AND DAC						
	Output Voltage Accuracy	VID0, VID1, VID2, VID3, VID4 see Table1; FBR = V _{OUT} ; FBG = GND	-0.6	-	0.6	%
I _{DAC}	VID pull-up Current	VID _x = GND	4	5	6	μA
	VID pull-up Voltage	VID _x = OPEN	3.2	-	3.5	V
ERROR AMPLIFIER						
	DC Gain			80		dB
SR	Slew-Rate	COMP=10pF		15		V/μs
DIFFERENTIAL AMPLIFIER (REMOTE BUFFER)						
	DC Gain			1		V/V
CMRR	Common Mode Rejection Ratio			40		dB

ELECTRICAL CHARACTERISTICS (continued) $V_{CC} = 12V \pm 10\%$, $T_J = 0$ to 70°C unless otherwise specified

Symbol	Parameter	Test Condition	Min	Typ	Max	Unit
SR	Slew Rate	$V_{SEN}=10\text{pF}$		15		$\text{V}/\mu\text{s}$
DIFFERENTIAL CURRENT SENSING						
I_{ISEN1} , I_{ISEN2}	Bias Current	$I_{LOAD} = 0$	45	50	55	μA
I_{PGNDSx}	Bias Current		45	50	55	μA
I_{ISEN1} , I_{ISEN2}	Bias Current at Over Current Threshold		80	85	90	μA
I_{FB}	Active Droop Current	$I_{LOAD} \leq 0\%$ $I_{LOAD} = 100\%$	47.5	0 50	1 52.5	μA μA
GATE DRIVERS						
t_{RISE} HGATE	High Side Rise Time	$V_{BOOTx}-V_{PHASEx}=10\text{V}$; C_{HGATEx} to $PHASEx=3.3\text{nF}$		15	30	ns
I_{HGATEx}	High Side Source Current	$V_{BOOTx}-V_{PHASEx}=10\text{V}$		2		A
R_{HGATEx}	High Side Sink Resistance	$V_{BOOTx}-V_{PHASEx}=12\text{V}$;	1.5	2	2.5	Ω
t_{RISE} LGATE	Low Side Rise Time	$V_{CCDR}=10\text{V}$; C_{LGATEx} to $PGNDx=5.6\text{nF}$		30	55	ns
I_{LGATEx}	Low Side Source Current	$V_{CCDR}=10\text{V}$		1.8		A
R_{LGATEx}	Low Side Sink Resistance	$V_{CCDR}=12\text{V}$	0.7	1.1	1.5	Ω
PROTECTIONS						
PGOOD	Upper Threshold (V_{SEN}/DAC Output)	V_{SEN} Rising	108	112	116	%
PGOOD	Lower Threshold (V_{SEN}/DAC Output)	V_{SEN} Falling	84	88	92	%
OVP	Over Voltage Threshold (V_{SEN})	V_{SEN} Rising	1.917	1.976	2.035	V
UVP	Under Voltage Trip (V_{SEN}/DAC Output)	V_{SEN} Falling	65	70	75	%
VPGOOD	PGOOD Voltage Low	$I_{PGOOD} = -4\text{mA}$	0.3	0.4	0.5	V

Table 1. Voltage Identification (VID) Codes

VID4	VID3	VID2	VID1	VID0	Output Voltage (V)	VID4	VID3	VID2	VID1	VID0	Output Voltage (V)
0	0	0	0	0	1.550	1	0	0	0	0	1.150
0	0	0	0	1	1.525	1	0	0	0	1	1.125
0	0	0	1	0	1.500	1	0	0	1	0	1.100
0	0	0	1	1	1.475	1	0	0	1	1	1.075
0	0	1	0	0	1.450	1	0	1	0	0	1.050
0	0	1	0	1	1.425	1	0	1	0	1	1.025
0	0	1	1	0	1.400	1	0	1	1	0	1.000
0	0	1	1	1	1.375	1	0	1	1	1	0.975
0	1	0	0	0	1.350	1	1	0	0	0	0.950
0	1	0	0	1	1.325	1	1	0	0	1	0.925
0	1	0	1	0	1.300	1	1	0	1	0	0.900
0	1	0	1	1	1.275	1	1	0	1	1	0.875
0	1	1	0	0	1.250	1	1	1	0	0	0.850
0	1	1	0	1	1.225	1	1	1	0	1	0.825
0	1	1	1	0	1.200	1	1	1	1	0	0.800
0	1	1	1	1	1.175	1	1	1	1	1	Shutdown

Reference Schematic

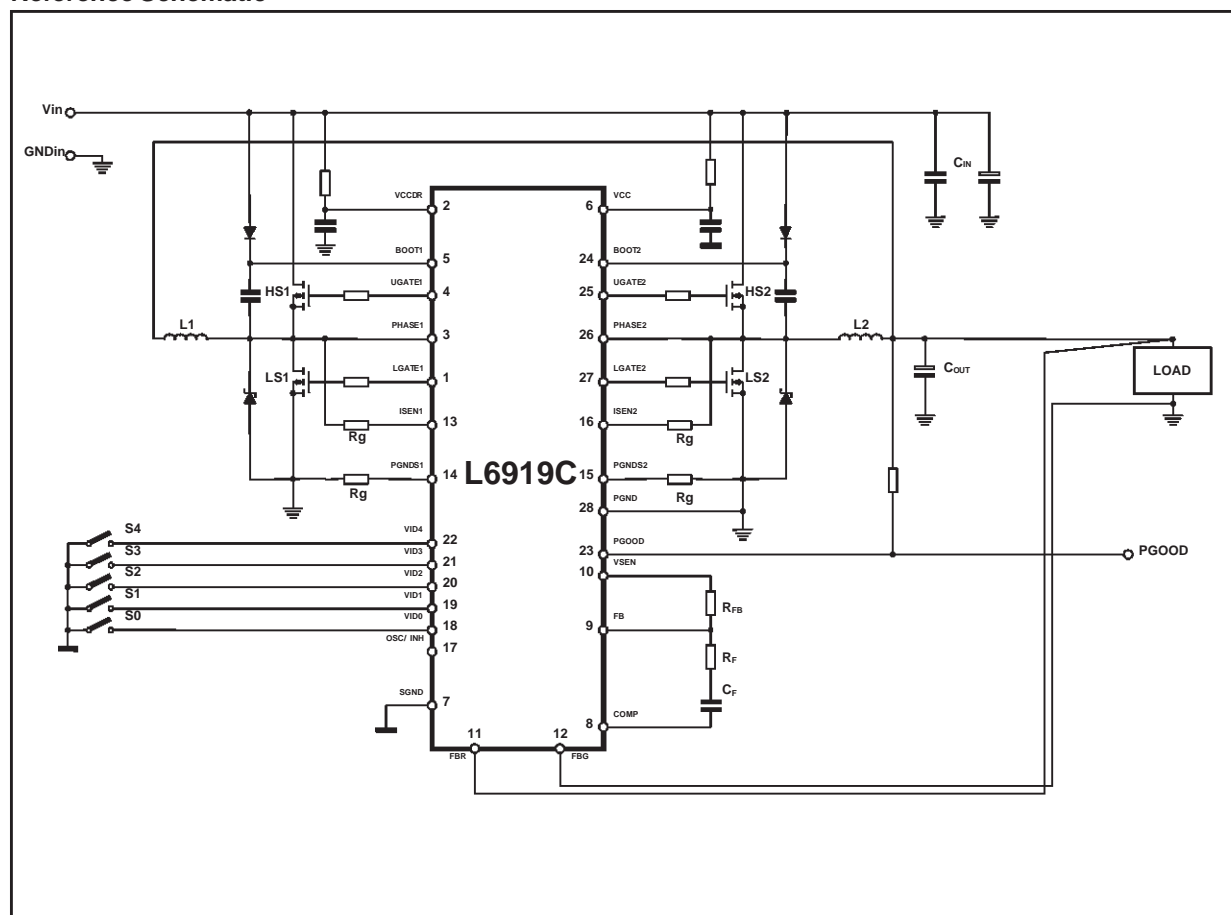

PIN FUNCTION

N	Name	Description
1	LGATE1	Channel 1 low side gate driver output.
2	VCCDR	LS Mosfet driver supply. It can be varied from 5V to 12V.
3	PHASE1	This pin is connected to the source of the upper mosfet and provides the return path for the high side driver of channel 1.
4	UGATE1	Channel 1 high side gate driver output.
5	BOOT1	Channel 1 bootstrap capacitor pin. Through this pin is supplied the high side driver and the upper mosfet. Connect through a capacitor to the PHASE1 pin and through a diode to Vcc (cathode vs. boot).
6	VCC	Device supply voltage. The operative supply voltage is 12V.
7	GND	All the internal references are referred to this pin. Connect it to the PCB signal ground.
8	COMP	This pin is connected to the error amplifier output and is used to compensate the control feedback loop.
9	FB	This pin is connected to the error amplifier inverting input and is used to compensate the voltage control feedback loop. A current proportional to the sum of the current sensed in both channel is sourced from this pin (50µA at full load, 70µA at the 140% Constant Current threshold). Connecting a resistor between this pin and VSEN pin allows programming the droop effect.
10	VSEN	Connected to the output voltage it is able to manage Over&Under-voltage conditions and the PGOOD signal. It is internally connected with the output of the Remote Sense Buffer for Remote Sense of the regulated voltage. If no Remote Sense is implemented, connect it directly to the regulated voltage in order to manage OVP, UVP and PGOOD.
11	FBR	Remote sense buffer non-inverting input. It has to be connected to the positive side of the load to perform a remote sense. If no remote sense is implemented, connect directly to the output voltage (in this case connect also the VSEN pin directly to the output regulated voltage).
12	FBG	Remote sense buffer inverting input. It has to be connected to the negative side of the load to perform a remote sense. Pull-down to ground if no remote sense is implemented.
13	ISEN1	Channel 1 current sense pin. The output current may be sensed across a sense resistor or across the low-side mosfet R _{dsON} . This pin has to be connected to the low-side mosfet drain or to the sense resistor through a resistor R _g in order to program the over current intervention for this phase at 140% as follow: $I_{OCPx} = \frac{35\mu A \cdot R_g}{R_{sense}}$ Where 35µA is the current offset information relative to the Over Current condition (offset at OC threshold minus offset at zero load). The net connecting the pin to the sense point must be routed as close as possible to the PGNDS1 net in order to couple in common mode any picked-up noise.
14	PGNDS1	Channel 1 Power Ground sense pin. The net connecting the pin to the sense point must be routed as close as possible to the ISEN1 net in order to couple in common mode any picked-up noise.
15	PGNDS2	Channel 2 Power Ground sense pin. The net connecting the pin to the sense point must be routed as close as possible to the ISEN2 net in order to couple in common mode any picked-up noise.

PIN FUNCTION (continued)

N	Name	Description
16	ISEN2	<p>Channel 2 current sense pin. The output current may be sensed across a sense resistor or across the low-side mosfet R_{dsON}. This pin has to be connected to the low-side mosfet drain or to the sense resistor through a resistor R_g in order to program the over current intervention for this phase at 140% as follow:</p> $I_{OCPx} = \frac{35\mu A \cdot R_g}{R_{sense}}$ <p>Where $35\mu A$ is the current offset information relative to the Over Current condition (offset at OC threshold minus offset at zero load). The net connecting the pin to the sense point must be routed as close as possible to the PGNDS2 net in order to couple in common mode any picked-up noise.</p>
17	OSC/ INH/ FAULT	<p>Oscillator switching frequency pin. Connecting an external resistor from this pin to GND, the external frequency is increased according to the equation:</p> $f_s = 200kHz + \frac{14.82 \cdot 10^6}{R_{OSC}(k\Omega)}$ <p>Connecting a resistor from this pin to Vcc (12V), the switching frequency is reduced according to the equation:</p> $f_s = 200kHz + \frac{12.91 \cdot 10^7}{R_{OSC}(k\Omega)}$ <p>If the pin is not connected, the switching frequency is 200KHz. Forcing the pin to a voltage lower than 0.6V, the device stop operation and enter the inhibit state. The pin is forced high when an Over/Under Voltage is detected. This condition is latched; to recover it is necessary turn off and on VCC.</p>
18-22	VID4-0	<p>Voltage IDentification pins. These input are internally pulled-up and TTL compatible. They are used to program the output voltage as specified in Table 1 and to set the power good thresholds. Connect to GND to program a '0' while leave floating to program a '1'.</p>
23	PGOOD	<p>This pin is an open collector output and is pulled low if the output voltage is not within the above specified thresholds. If not used may be left floating.</p>
24	BOOT2	<p>Channel 2 bootstrap capacitor pin. Through this pin is supplied the high side driver and the upper mosfet. Connect through a capacitor to the PHASE2 pin and through a diode to Vcc (cathode vs. boot).</p>
25	UGATE2	<p>Channel 2 high side gate driver output.</p>
26	PHASE2	<p>This pin is connected to the source of the upper mosfet and provides the return path for the high side driver of channel 2.</p>
27	LGATE2	<p>Channel 2 low side gate driver output.</p>
28	PGND	<p>Power ground pin. This pin is common to both sections and it must be connected through the closest path to the low side mosfets source pins in order to reduce the noise injection into the device.</p>

DEVICE DESCRIPTION

The device is an integrated circuit realized in BCD technology. It provides complete control logic and protections for a high performance dual-phase step-down DC-DC converter optimized for microprocessor power supply. It is designed to drive N Channel MOSFETs in a dual-phase synchronous-rectified buck topology. A 180 deg phase shift is provided between the two phases allowing reduction in the input capacitor current ripple, reducing also the size and the losses. The output voltage of the converter can be precisely regulated, programming the VID pins, from 0.800V to 1.550V with 25mV binary steps, with a maximum tolerance of ±0.6% over temperature and line voltage variations. The device manages On-The-Fly VID Code changes stepping to the new configuration following the VID table with no need for external components. The device provides an average current-mode control with fast transient response. It includes a 200kHz free-running oscillator. The error amplifier features a 15V/μs slew rate that permits high converter bandwidth for fast transient performances. Current information is read across the lower mosfets R_{dsON} or across a sense resistor in fully differential mode. The current information corrects the PWM output in order to equalize the average current carried by each phase. Current sharing between the two phases is then limited at ±10% over static and dynamic conditions. The device protects against Over-Current, with an OC threshold for each phase, entering in constant current mode. Since the current is read across the low side mosfets, the constant current keeps constant the bottom of the inductors current triangular waveform. When an under voltage is detected the device latches and the FAULT pin is driven high. The device performs also Over-Voltage protection that disables immediately the device turning ON the lower driver and driving high the FAULT pin.

OSCILLATOR

The switching frequency is internally fixed to 200kHz. The internal oscillator generates the triangular waveform for the PWM charging and discharging with a constant current an internal capacitor. The current delivered to the oscillator is typically 17μA (F_{sw}=200KHz) and may be varied using an external resistor (R_{OSC}) connected between OSC pin and GND or V_{cc}. Since the OSC pin is maintained at fixed voltage (Typ. 1.235V), the frequency is varied proportionally to the current sunk (forced) from (into) the pin considering the internal gain of 12KHz/μA.

In particular connecting it to GND the frequency is increased (current is sunk from the pin), while connecting R_{OSC} to V_{cc}=12V the frequency is reduced (current is forced into the pin), according to the following relationships:

$$R_{OSC} \text{ vs. GND: } f_s = 200\text{kHz} + \frac{1.237}{R_{OSC}(\text{K}\Omega)} \cdot 12 \frac{\text{kHz}}{\mu\text{A}} = 200\text{kHz} + \frac{14.82 \cdot 10^6}{R_{OSC}(\text{K}\Omega)}$$

$$R_{OSC} \text{ vs. 12V: } f_s = 200\text{kHz} - \frac{12 - 1.237}{R_{OSC}(\text{K}\Omega)} \cdot 12 \frac{\text{kHz}}{\mu\text{A}} = 200\text{kHz} - \frac{12.918 \cdot 10^7}{R_{OSC}(\text{K}\Omega)}$$

Note that forcing a 17μA current into this pin, the device stops switching because no current is delivered to the oscillator.

Figure 1. R_{osc} vs. Switching Frequency

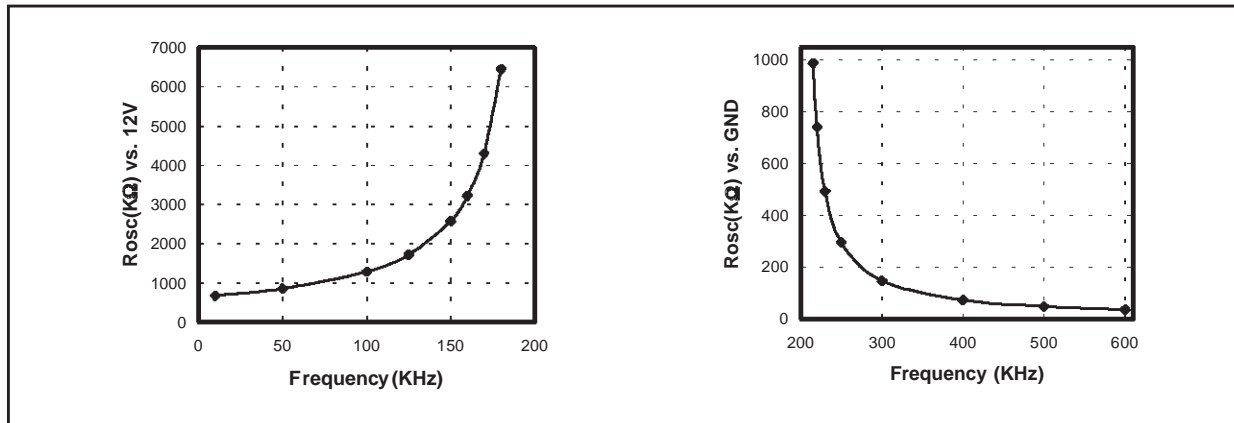

DIGITAL TO ANALOG CONVERTER

The built-in digital to analog converter allows the adjustment of the output voltage from 0.800V to 1.550V with 25mV as shown in the previous table 1. The internal reference is trimmed to ensure output voltage precision of $\pm 0.6\%$ and a zero temperature coefficient around 70°C. The internal reference voltage for the regulation is programmed by the voltage identification (VID) pins. These are TTL compatible inputs of an internal DAC that is realized by means of a series of resistors providing a partition of the internal voltage reference. The VID code drives a multiplexer that selects a voltage on a precise point of the divider. The DAC output is delivered to an amplifier obtaining the V_{PROG} voltage reference (i.e. the set-point of the error amplifier). Internal pull-ups are provided (realized with a 5 μ A current generator up to 3.3V Typ); in this way, to program a logic "1" it is enough to leave the pin floating, while to program a logic "0" it is enough to short the pin to GND. Programming the "11111" code, the device enters the NOCPU mode: all mosfets are turned OFF and protections are disabled. The condition is latched.

The voltage identification (VID) pin configuration also sets the power-good thresholds (PGOOD) and the Over / Under Voltage protection (OVP/UVP) thresholds.

DYNAMIC VID TRANSITION

The device is able to manage On-The-Fly VID Code changes that allow Output Voltage modification during normal device operation. The device checks every clock cycle (synchronously with the PWM ramp) for VID code modifications. Once the new code is stable for more than one clock cycle, the reference steps up or down in 25mV increments every clock cycle until the new VID code is reached. During the transition, VID code changes are ignored; the device re-starts monitoring VID after the transition has finished. PGOOD, signal is masked during the transition and it is re-activated after the transition has finished while OVP / UVP are still active.

Figure 2. Dynamic VID transition

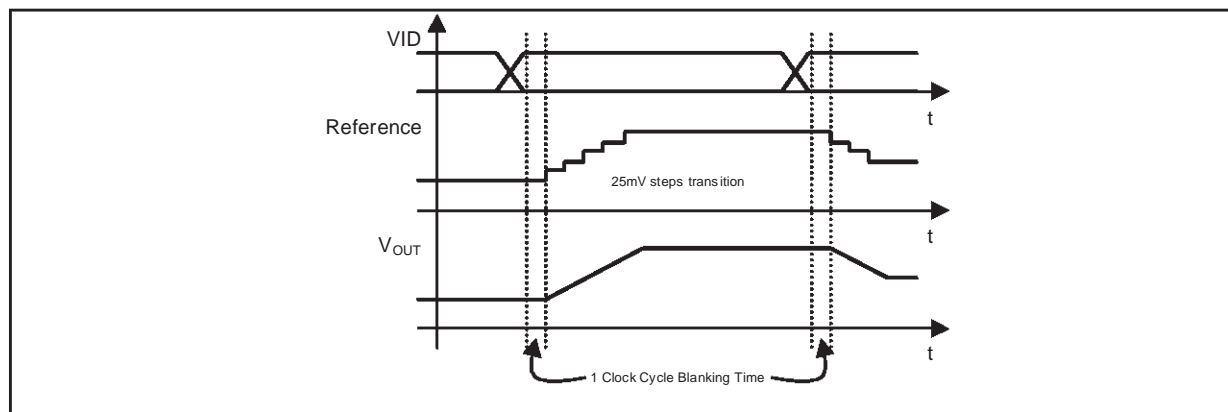

SOFT START AND INHIBIT

At start-up a ramp is generated increasing the loop reference from 0V to the final value programmed by VID in 2048 clock periods as shown in figure 3.

Before soft start, the lower power MOS are turned ON after that VCCDR reaches 2V (independently by V_{cc} value) to discharge the output capacitor and to protect the load from high side mosfet failures. Once soft start begins, the reference is increased; also the upper MOS begins to switch and the output voltage starts to increase with closed loop regulation. At the end of the digital soft start, the Power Good comparator is enabled and the PGOOD signal is then driven high (See fig. 3). The Under Voltage comparator enabled when the reference voltage reaches 0.8V. The Soft-Start will not take place, if both VCC and VCCDR pins are not above their own turn-on thresholds. During normal operation, if any under-voltage is detected on one of the two supplies the device shuts down. Forcing the OSC/INH/FAULT pin to a voltage lower than 0.6V (Typ.), the device enters in INHIBIT mode: all the power mosfets are turned off and protections are disabled.

Setting the INH pin free, causes the device to restart.

Figure 3. Soft Start

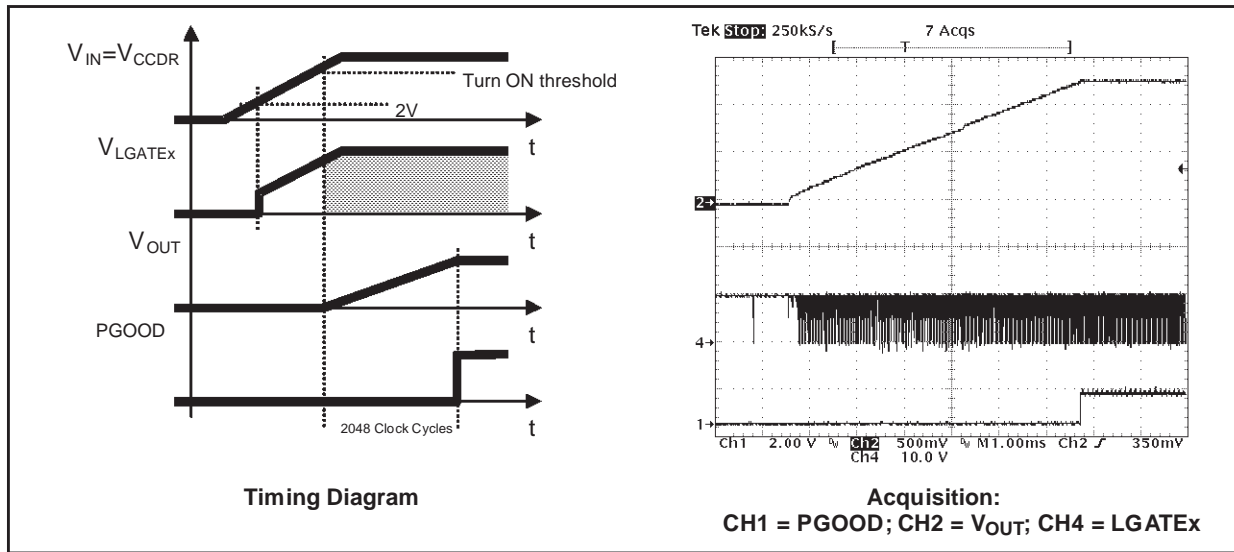
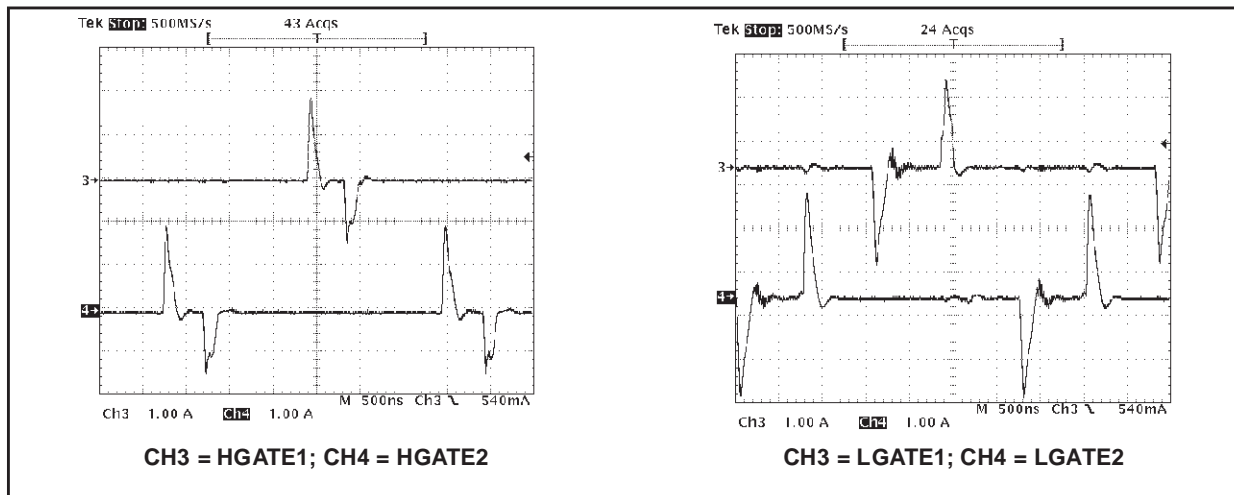

Figure 4. Drivers peak current: High Side (left) and Low Side (right)



DRIVER SECTION

The integrated high-current drivers allow using different types of power MOS (also multiple MOS to reduce the $R_{ds(ON)}$), maintaining fast switching transition.

The drivers for the high-side mosfets use BOOTx pins for supply and PHASEx pins for return. The drivers for the low-side mosfets use VCCDRV pin for supply and PGND pin for return. A minimum voltage of 4.6V at VC-CDRV pin is required to start operations of the device.

The controller embodies a sophisticated anti-shoot-through system to minimize low side body diode conduction time maintaining good efficiency saving the use of Schottky diodes. The dead time is reduced to few nanoseconds assuring that high-side and low-side mosfets are never switched on simultaneously: when the high-side mosfet turns off, the voltage on its source begins to fall; when the voltage reaches 2V, the low-side mosfet gate drive is applied with 30ns delay. When the low-side mosfet turns off, the voltage at LGATEx pin is sensed. When it drops below 1V, the high-side mosfet gate drive is applied with a delay of 30ns. If the current flowing in the inductor is negative, the source of high-side mosfet will never drop. To allow the turning on of the low-side mosfet even in this case, a watchdog controller is enabled: if the source of the high-side mosfet don't drop for more than 240ns, the low side mosfet is switched on so allowing the negative current of the inductor to recirculate. This mechanism allows the system to regulate even if the current is negative.

The BOOTx and VCCDR pins are separated from IC's power supply (VCC pin) as well as signal ground (SGND pin) and power ground (PGND pin) in order to maximize the switching noise immunity. The separated supply for the different drivers gives high flexibility in mosfet choice, allowing the use of logic-level mosfet. Several combination of supply can be chosen to optimize performance and efficiency of the application. Power conversion is also flexible; 5V or 12V bus can be chosen freely.

The peak current is shown for both the upper and the lower driver of the two phases in figure 3. A 10nF capacitive load has been used. For the upper drivers, the source current is 1.9A while the sink current is 1.5A with $V_{BOOT} - V_{PHASE} = 12V$; similarly, for the lower drivers, the source current is 2.4A while the sink current is 2A with $V_{CCDR} = 12V$.

CURRENT READING AND OVER CURRENT

The current flowing through each phase is read using the voltage drop across the low side mosfets R_{dsON} or across a sense resistor (R_{SENSE}) and internally converted into a current. The Trans conductance ratio is issued by the external resistor R_g placed outside the chip between ISENx and PGNDsx pins toward the reading points. The full differential current reading rejects noise and allows to place sensing element in different locations without affecting the measurement's accuracy. The current reading circuitry reads the current during the time in which the low-side mosfet is on (OFF Time). During this time, the reaction keeps the pin ISENx and PGNDsx at the same voltage while during the time in which the reading circuitry is off, an internal clamp keeps these two pins at the same voltage sinking from the ISENx pin the necessary current (Needed if low-side mosfet R_{dsON} sense is implemented to avoid absolute maximum rating overcome on ISENx pin).

The proprietary current reading circuit allows a very precise and high bandwidth reading for both positive and negative current. This circuit reproduces the current flowing through the sensing element using a high speed Track & Hold Trans conductance amplifier. In particular, it reads the current during the second half of the OFF time reducing noise injection into the device due to the mosfet turn-on (See fig. 5). Track time must be at least 200ns to make proper reading of the delivered current

Figure 5. Current Reading Timing (Left) and Circuit (Right)

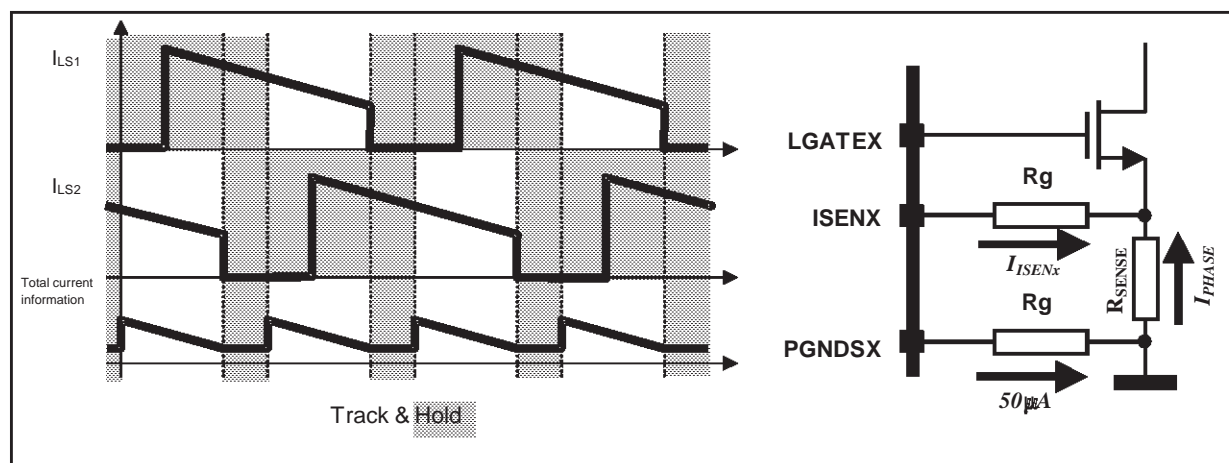

This circuit sources a constant 50µA current from the PGNDsx pin and keeps the pins ISENx and PGNDsx at the same voltage. Referring to figure 4, the current that flows in the ISENx pin is then given by the following equation:

$$I_{ISENx} = 50\mu A + \frac{R_{SENSE} \cdot I_{PHASE}}{R_g} = 50\mu A + I_{INFOx}$$

Where R_{SENSE} is an external sense resistor or the $r_{ds,on}$ of the low side mosfet and R_g is the transconductance resistor used between ISENx and PGNDsx pins toward the reading points; I_{PHASE} is the current carried by each phase and, in particular, the current measured in the middle of the oscillator period

The current information reproduced internally is represented by the second term of the previous equation as

follow:

$$I_{INFOx} = \frac{R_{SENSE} \cdot I_{PHASE}}{R_g}$$

Since the current is read in differential mode, also negative current information is kept; this allow the device to check for dangerous returning current between the two phases assuring the complete equalization between the phase's currents. From the current information of each phase, information about the total current delivered ($I_{FB} = I_{INFO1} + I_{INFO2}$) and the average current for each phase ($I_{AVG} = (I_{INFO1} + I_{INFO2})/2$) is taken. I_{INFOx} is then compared to I_{AVG} to give the correction to the PWM output in order to equalize the current carried by the two phases. The transconductance resistor R_g can be designed in order to have current information of $25\mu A$ per phase at full nominal load; the over current intervention threshold is set at 140% of the nominal ($I_{INFOx} = 35\mu A$). According to the above relationship, the over current threshold (I_{OCPx}) for each phase, which has to be placed at one half of the total delivered maximum current, results:

$$I_{OCPx} = \frac{35\mu A \cdot R_g}{R_{SENSE}} \quad R_g = \frac{I_{OCPx} \cdot R_{SENSE}}{35\mu A}$$

Since the device senses the output current across the low-side mosfets (or across a sense resistors in series with them) the device limits the bottom of the inductor current triangular waveform: an over current is detected when the current flowing into the sense element is greater than I_{OCPx} ($I_{INFOx} > 35\mu A$).

Introducing now the maximum ON time dependence with the delivered current (where T is the switching period $T=1/f_{SW}$):

$$T_{ON,MAX} = 0.80 - (I_{FB} \cdot 5.73k) \cdot T = 0.80 - \left(\frac{R_{SENSE}}{R_g} \cdot I_{OUT} \cdot 5.73k \right) \cdot T \begin{cases} 0.80 \cdot T & I_{FB} = 0\mu A \\ 0.40 \cdot T & I_{FB} = 70\mu A \end{cases}$$

This linear dependence has a value at zero load of $0.80 \cdot T$ and at maximum current of $0.40 \cdot T$ typical and results in two different behaviors of the device:

1. T_{ON} Limited Output Voltage.

This happens when the maximum ON time is reached before the current in each phase reaches I_{OCPx} ($I_{INFOx} < 35\mu A$).

Figure 6a shows the maximum output voltage that the device is able to regulate considering the T_{ON} limitation imposed by the previous relationship. If the desired output characteristic crosses the T_{ON} limited maximum output voltage, the output resulting voltage will start to drop after crossing. In this case, the device doesn't perform constant current limitation but only limits the maximum ON time following the previous relationship. The output voltage follows the resulting characteristic (dotted in Figure 6b) until UVP is detected or anyway until $I_{FB} = 70\mu A$.

Figure 6. T_{ON} Limited Operation

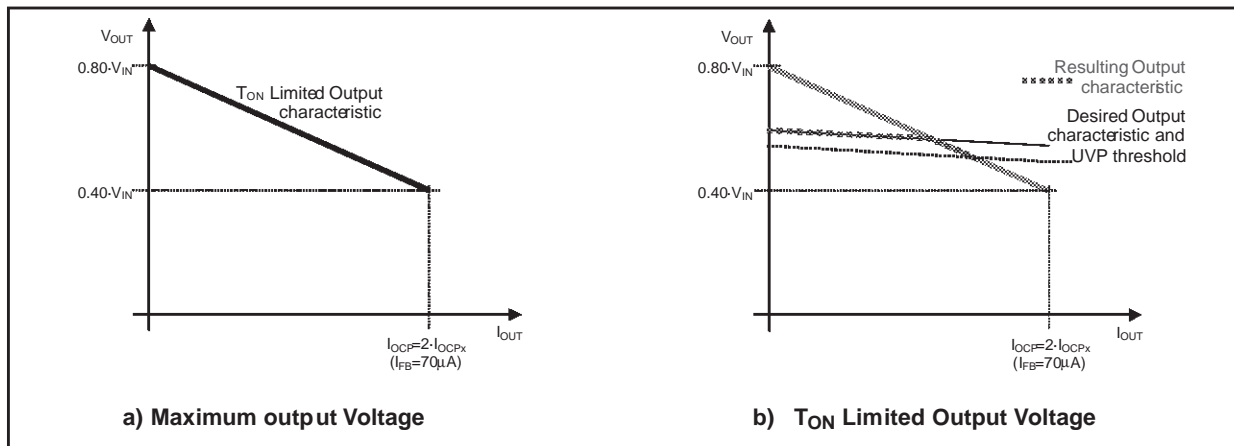

2. Constant Current Operation

This happens when ON time limitation is reached after the current in each phase reaches I_{OCPx} ($I_{INFOx} > 35\mu A$).

The device enters in Quasi-Constant-Current operation: the low-side mosfets stays ON until the current read becomes lower than I_{OCPx} ($I_{INFOx} < 35\mu A$) skipping clock cycles. The high side mosfets can be turned ON with a T_{ON} imposed by the control loop at the next available clock cycle and the device works in the usual way until another OCP event is detected.

This means that the average current delivered can slightly increase also in Over Current condition since the current ripple increases. In fact, the ON time increases due to the OFF time rise because of the current has to reach the I_{OCPx} bottom. The worst-case condition is when the ON time reaches its maximum value.

When this happens, the device works in Constant Current and the output voltage decrease as the load increase. Crossing the UVP threshold causes the device to latch (FAULT pin is driven high).

Figure 7 shows this working condition

Figure 7. Constant Current operation

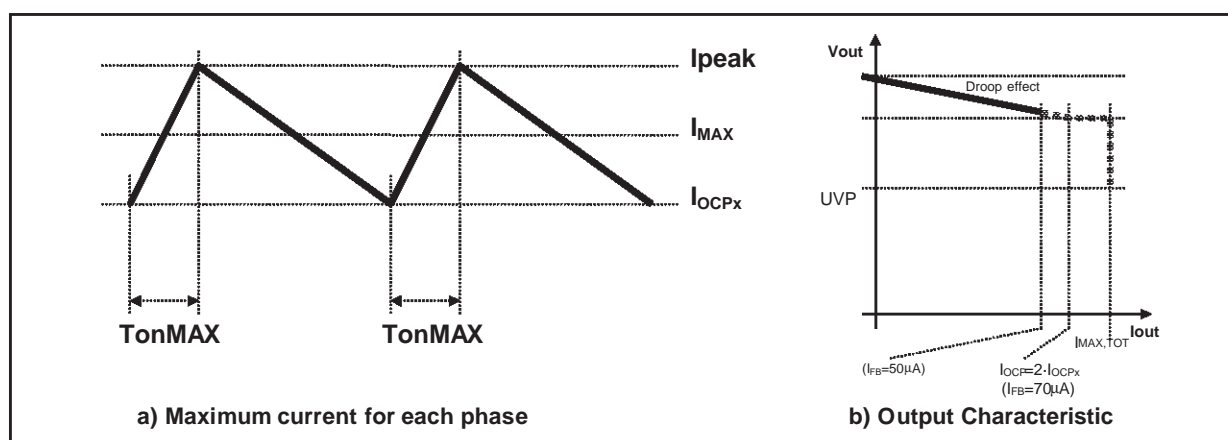

It can be observed that the peak current (I_{peak}) is greater than the I_{OCPx} but it can be determined as follow:

$$I_{peak} = I_{OCPx} + \frac{V_{IN} - V_{out_{MIN}}}{L} \cdot T_{on_{MAX}} = I_{OCPx} + \frac{V_{IN} - V_{out_{MIN}}}{L} \cdot 0.40 \cdot T$$

Where $V_{out_{MIN}}$ is the minimum output voltage (VID-30% as follow).

The device works in Constant-Current, and the output voltage decreases as the load increase, until the output voltage reaches the Under-Voltage threshold ($V_{out_{MIN}}$). When this threshold is crossed, all mosfets are turned off, the FAULT pin is driven high and the device stops working. Cycle the power supply to restart operation. The maximum average current during the Constant-Current behavior results:

$$I_{MAX,TOT} = 2 \cdot I_{MAX} + 2 \cdot \left(I_{OCPx} + \frac{I_{peak} - I_{OCPx}}{2} \right)$$

In this particular situation, the switching frequency results reduced. The ON time is the maximum allowed ($T_{on_{MAX}}$) while the OFF time depends on the application:

$$T_{OFF} = L \cdot \frac{I_{peak} - I_{OCPx}}{V_{OUT}} \quad f = \frac{1}{T_{ONmax} + T_{OFF}}$$

Over current is set anyway when I_{INFOx} reaches $35\mu A$ ($I_{FB} = 70\mu A$). The full load value is only a convention to work with convenient values for I_{FB} . Since the OCP intervention threshold is fixed, to modify the percentage with respect to the load value, it can be simply considered that, for example, to have an OCP threshold of 170%, this will correspond to $I_{INFOx} = 35\mu A$ ($I_{FB} = 70\mu A$). The full load current will then correspond to $I_{INFOx} = 20.6\mu A$ ($I_{FB} = 41.1\mu A$).

Integrated Droop Function

The device uses a droop function to satisfy the requirements of high performance microprocessors, reducing the size and the cost of the output capacitor.

This method "recovers" part of the drop due to the output capacitor ESR in the load transient, introducing a dependence of the output voltage on the load current

As shown in figure 8, the ESR drop is present in any case, but using the droop function the total deviation of the output voltage is minimized. In practice the droop function introduces a static error (V_{DROOP} in figure 8) proportional to the output current. Since the device has an average current mode regulation, the information about the total current delivered is used to implement the Droop Function. This current (equal to the sum of both I_{INFOx}) is sourced from the FB pin. Connecting a resistor between this pin and V_{OUT} , the total current information flows only in this resistor because the compensation network between FB and COMP has always a capacitor in series (See fig. 9). The voltage regulated is then equal to:

$$V_{OUT} = V_{ID} - R_{FB} \cdot I_{FB}$$

Since I_{FB} depends on the current information about the two phases, the output characteristic vs. load current is given by:

$$V_{OUT} = V_{ID} - R_{FB} \cdot \frac{R_{SENSE}}{R_g} \cdot I_{OUT}$$

Figure 8. Output transient response without (a) and with (b) the droop function

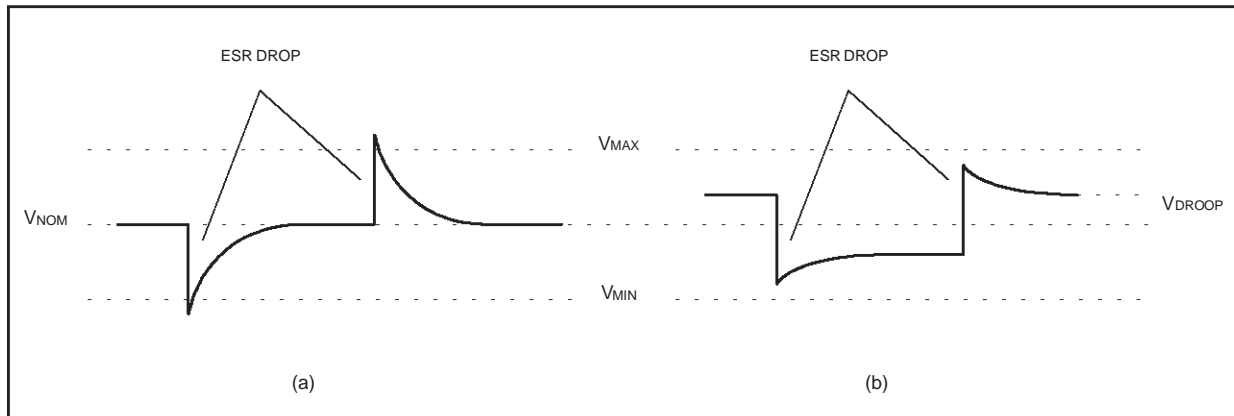
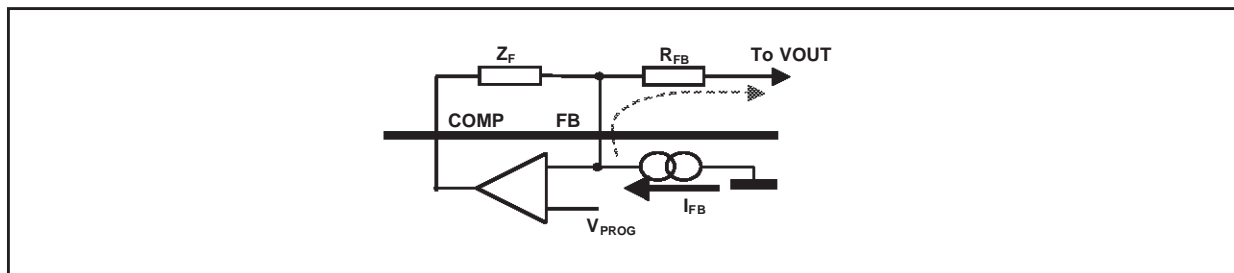

Figure 9. Active Droop Function Circuit



The feedback current is equal to $50\mu A$ at nominal full load ($I_{FB} = I_{INFO1} + I_{INFO2}$) and $70\mu A$ at the OC intervention threshold, so the maximum output voltage deviation is equal to:

$$\Delta V_{FULL_POSITIVE_LOAD} = -R_{FB} \cdot 50\mu A \qquad \Delta V_{OC_INTERVENTION} = -R_{FB} \cdot 70\mu A$$

Droop function is provided only for positive load; if negative load is applied, and then $I_{INFOx} < 0$, no current is sunk from the FB pin. The device regulates at the voltage programmed by the VID.

OUTPUT VOLTAGE MONITOR AND PROTECTIONS

The output voltage is monitored by pin VSEN. If it is not within $\pm 12\%$ (Typ.) of the programmed value, the power good output is forced low. Power good is an open drain output and it is enabled only after the soft start is finished (2048 clock cycles after start-up).

The device provides over voltage protection; when the voltage sensed by the VSEN pin reaches 1.976V (typ.), the controller permanently switches on both the low-side mosfets and switches off both the high-side mosfets in order to protect the CPU. The OSC/INH/FAULT pin is driven high (5V) and power supply (Vcc) turn off and on is required to restart operations. The over Voltage percentage is set by the ratio between the OVP threshold (set at 1.976V) and the reference programmed by VID.

$$\text{OVP}[\%] = \frac{1.976\text{V}}{\text{ReferenceVoltage(VID)}} - 100$$

Under voltage protection is also provided. If the output voltage drops below the 70% of the reference voltage for more than one clock period the device turns off and the FAULT is driven high.

Both Over Voltage and Under Voltage are active also during soft start (Under Voltage after than V_{OUT} reaches 0.8V). During soft-start the reference voltage used to determine the UV threshold is the increasing voltage driven by the 2048 soft start digital counter.

REMOTE VOLTAGE SENSE

A remote sense buffer is integrated into the device to allow output voltage remote sense implementation without any additional external components. In this way, the output voltage programmed is regulated between the remote buffer inputs compensating motherboard trace losses or connector losses if the device is used for a VRM module. The very low offset amplifier senses the output voltage remotely through the pins FBR and FBG (FBR is for the regulated voltage sense while FBG is for the ground sense) and reports this voltage internally at VSEN pin with unity gain eliminating the errors.

If remote sense is not required, the output voltage is sensed by the VSEN pin connecting it directly to the output voltage. In this case the FBG and FBR pins must be connected anyway to the regulated voltage.

INPUT CAPACITOR

The input capacitor is designed considering mainly the input RMS current that depends on the duty cycle as reported in figure 10. Considering the dual-phase topology, the input RMS current is highly reduced comparing with a single phase operation.

Figure 10. Input RMS Current vs. Duty Cycle (D) and Driving Relationships

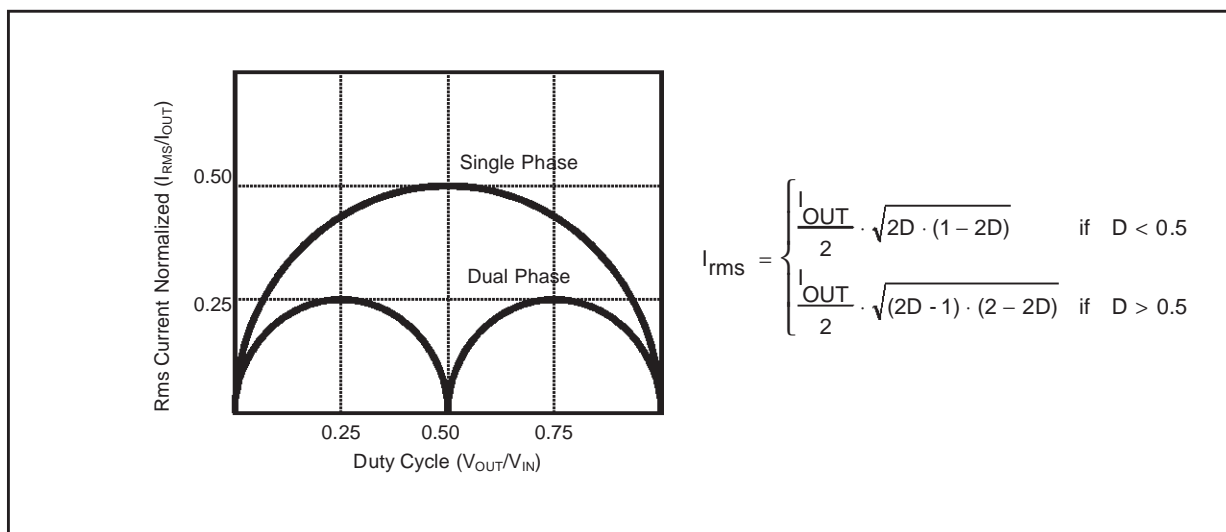

It can be observed that the input rms value is one half of the single-phase equivalent input current in the worst case condition that happens for $D = 0.25$ and $D = 0.75$.

The power dissipated by the input capacitance is then equal to:

$$P_{RMS} = ESR \cdot (I_{RMS})^2$$

Input capacitor is designed in order to sustain the ripple relative to the maximum load duty cycle. To reach the high RMS value needed by the CPU power supply application and also to minimize components cost, the input capacitance is realized by more than one physical capacitor. The equivalent RMS current is simply the sum of the single capacitor's RMS current.

Input bulk capacitor must be equally divided between high-side drain mosfets and placed as close as possible to reduce switching noise above all during load transient. Ceramic capacitor can also introduce benefits in high frequency noise decoupling, noise generated by parasitic components along power path.

OUTPUT CAPACITOR

Since the microprocessors require a current variation beyond 50A doing load transients, with a slope in the range of tenth A/ μ s, the output capacitor is a basic component for the fast response of the power supply.

Dual phase topology reduces the amount of output capacitance needed because of faster load transient response (switching frequency is doubled at the load connections). Current ripple cancellation due to the 180° phase shift between the two phases also reduces requirements on the output ESR to sustain a specified voltage ripple.

When a load transient is applied to the converter's output, for first few microseconds the current to the load is supplied by the output capacitors. The controller recognizes immediately the load transient and increases the duty cycle, but the current slope is limited by the inductor value.

The output voltage has a first drop due to the current variation inside the capacitor (neglecting the effect of the ESL):

$$\Delta V_{OUT} = \Delta I_{OUT} \cdot ESR$$

A minimum capacitor value is required to sustain the current during the load transient without discharge it. The voltage drop due to the output capacitor discharge is given by the following equation:

$$\Delta V_{OUT} = \frac{\Delta I_{OUT}^2 \cdot L}{2 \cdot C_{OUT} \cdot (V_{IN} \cdot D_{MAX} - V_{OUT})}$$

Where D_{MAX} is the maximum duty cycle value. The lower is the ESR, the lower is the output drop during load transient and the lower is the output voltage static ripple.

INDUCTOR DESIGN

The inductance value is defined by a compromise between the transient response time, the efficiency, the cost and the size. The inductor has to be calculated to sustain the output and the input voltage variation to maintain the ripple current ΔI_L between 20% and 30% of the maximum output current. The inductance value can be calculated with this relationship:

$$L = \frac{V_{IN} - V_{OUT}}{f_{SW} \cdot \Delta I_L} \cdot \frac{V_{OUT}}{V_{IN}}$$

Where f_{SW} is the switching frequency, V_{IN} is the input voltage and V_{OUT} is the output voltage.

Increasing the value of the inductance reduces the ripple current but, at the same time, reduces the converter response time to a load transient. The response time is the time required by the inductor to change its current from initial to final value. Since the inductor has not finished its charging time, the output current is supplied by the output capacitors. Minimizing the response time can minimize the output capacitance required.

The response time to a load transient is different for the application or the removal of the load: if during the ap-

plication of the load the inductor is charged by a voltage equal to the difference between the input and the output voltage, during the removal it is discharged only by the output voltage. The following expressions give approximate response time for ΔI load transient in case of enough fast compensation network response:

$$t_{\text{application}} = \frac{L \cdot \Delta I}{V_{\text{IN}} - V_{\text{OUT}}} \quad t_{\text{removal}} = \frac{L \cdot \Delta I}{V_{\text{OUT}}}$$

The worst condition depends on the input voltage available and the output voltage selected. Anyway the worst case is the response time after removal of the load with the minimum output voltage programmed and the maximum input voltage available.

Figure 11. Inductor ripple current vs V_{OUT}

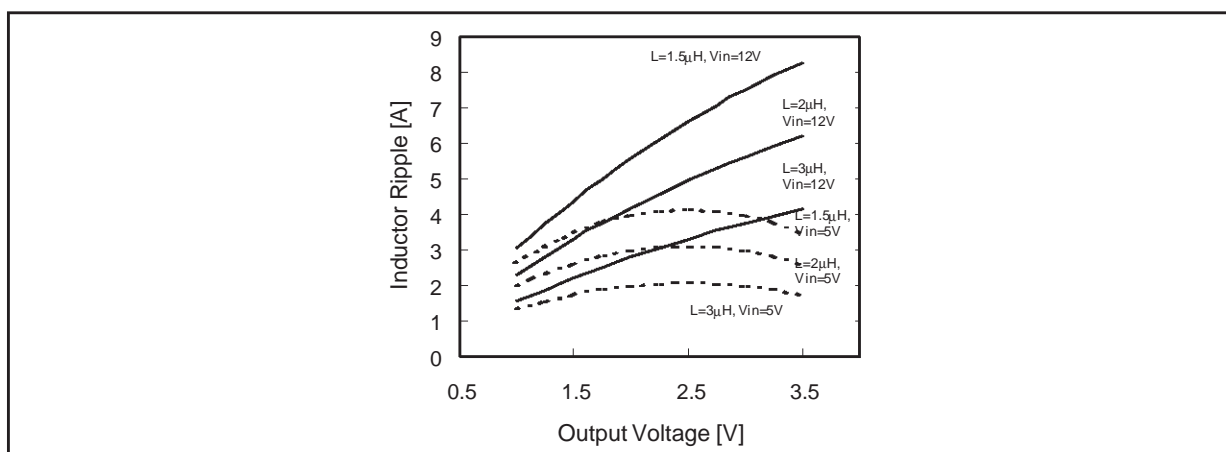

MAIN CONTROL LOOP

The control loop is composed by the Current Sharing control loop and the Average Current Mode control loop. Each loop gives, with a proper gain, the correction to the PWM in order to minimize the error in its regulation: the Current Sharing control loop equalize the currents in the inductors while the Average Current Mode control loop fixes the output voltage equal to the reference programmed by VID. Figure 12 reports the block diagram of the main control loop.

Figure 12. Main Control Loop Diagram

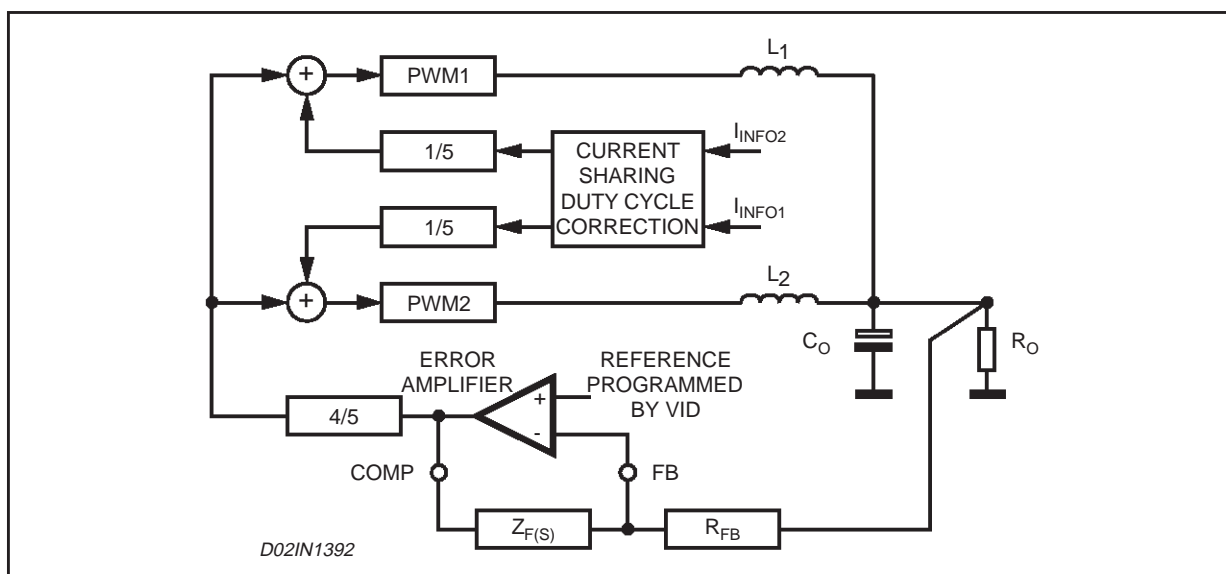

Current Sharing (CS) Control Loop

Active current sharing is implemented using the information from Transconductance differential amplifier in an average current mode control scheme. A current reference equal to the average of the read current (I_{AVG}) is internally built; the error between the read current and this reference is converted to a voltage with a proper gain and it is used to adjust the duty cycle whose dominant value is set by the error amplifier at COMP pin (See fig. 13).

The current sharing control is a high bandwidth control loop allowing current sharing even during load transients. The current sharing error is affected by the choice of external components; choose precise R_g resistor ($\pm 1\%$ is necessary) to sense the current. The current sharing error is internally dominated by the voltage offset of Transconductance differential amplifier; considering a voltage offset equal to 2mV across the sense resistor, the current reading error is given by the following equation:

$$\frac{\Delta I_{READ}}{I_{MAX}} = \frac{2mV}{R_{SENSE} \cdot I_{MAX}}$$

Where ΔI_{READ} is the difference between one phase current and the ideal current ($I_{MAX}/2$).

For $R_{SENSE} = 4m\Omega$ and $I_{MAX} = 40A$ the current sharing error is equal to 2.5%, neglecting errors due to R_g and R_{sense} mismatches.

Figure 13. Current Sharing Control Loop

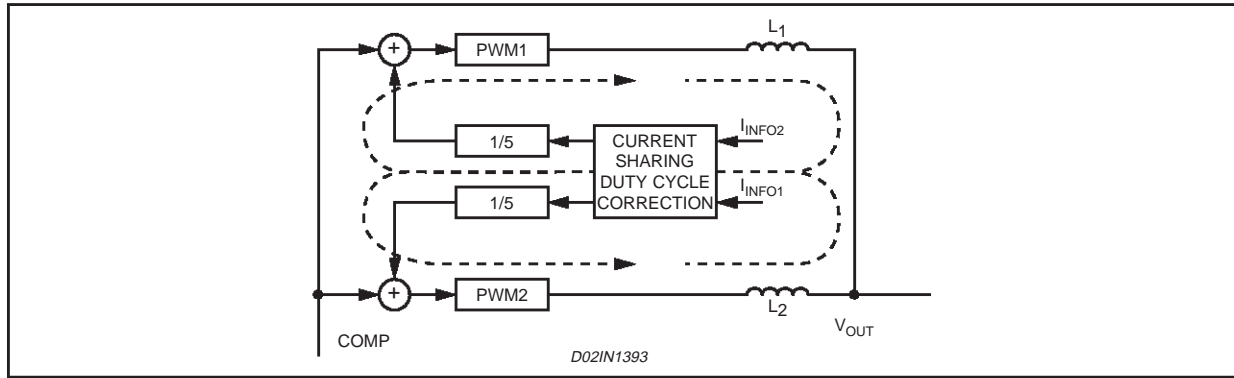

Average Current Mode (ACM) Control Loop

The average current mode control loop is reported in figure 14. The current information I_{FB} sourced by the FB pin flows into RFB implementing the dependence of the output voltage from the read current.

The ACM control loop gain results (obtained opening the loop after the COMP pin):

$$G_{LOOP}(s) = \frac{PWM \cdot Z_F(s) \cdot (R_{DROOP} + Z_P(s))}{(Z_P(s) + Z_L(s)) \cdot \left[\frac{Z_F(s)}{A(s)} + \left(1 + \frac{1}{A(s)} \right) \cdot R_{FB} \right]}$$

Where:

- $R_{DROOP} = \frac{R_{sense}}{R_g} \cdot R_{FB}$ is the equivalent output resistance determined by the droop function;
- $Z_P(s)$ is the impedance resulting by the parallel of the output capacitor (and its ESR) and the applied load R_o ;
- $Z_F(s)$ is the compensation network impedance;
- $Z_L(s)$ is the parallel of the two inductor impedance;
- $A(s)$ is the error amplifier gain;

– $PWM = \frac{4}{5} \cdot \frac{\Delta V_{IN}}{\Delta V_{OSC}}$ is the ACM PWM transfer function where ΔV_{OSC} is the oscillator ramp amplitude

and has a typical value of 2V

Removing the dependence from the Error Amplifier gain, so assuming this gain high enough, the control loop gain results:

$$G_{LOOP}(s) = -\frac{4}{5} \cdot \frac{V_{IN}}{\Delta V_{OSC}} \cdot \frac{Z_F(s)}{Z_P(s) + Z_L(s)} \cdot \left(\frac{R_S}{R_G} + \frac{Z_P(s)}{R_{FB}} \right)$$

With further simplifications, it results:

$$G_{LOOP}(s) = -\frac{4}{5} \cdot \frac{V_{IN}}{\Delta V_{OSC}} \cdot \frac{Z_F(s)}{R_{FB}} \cdot \frac{R_O + R_{DROOP}}{R_O + \frac{R_L}{2}} \cdot \frac{1 + s \cdot C_O \cdot (R_{DROOP} // R_O + ESR)}{s^2 \cdot C_O \cdot \frac{L}{2} + s \cdot \left[\frac{L}{2 \cdot R_O} + C_O \cdot ESR + C_O \cdot \frac{R_L}{2} \right] + 1}$$

Considering now that in the application of interest it can be assumed that $R_O \gg R_L$; $ESR \ll R_O$ and $R_{DROOP} \ll R_O$, it results:

$$G_{LOOP}(s) = -\frac{4}{5} \cdot \frac{V_{IN}}{\Delta V_{OSC}} \cdot \frac{Z_F(s)}{R_{FB}} \cdot \frac{1 + s \cdot C_O \cdot (R_{DROOP} + ESR)}{s^2 \cdot C_O \cdot \frac{L}{2} + s \cdot \left[\frac{L}{2 \cdot R_O} + C_O \cdot ESR + C_O \cdot \frac{R_L}{2} \right] + 1}$$

The ACM control loop gain is designed to obtain a high DC gain to minimize static error and cross the 0dB axes with a constant -20dB/dec slope with the desired crossover frequency ω_T . Neglecting the effect of $Z_F(s)$, the transfer function has one zero and two poles. Both the poles are fixed once the output filter is designed and the zero is fixed by ESR and the Droop resistance. To obtain the desired shape an R_F - C_F series network is considered for the $Z_F(s)$ implementation. A zero at $\omega_F = 1/R_F C_F$ is then introduced together with an integrator. This integrator minimizes the static error while placing the zero in correspondence with the L-C resonance a simple -20dB/dec shape of the gain is assured (See Figure 14). In fact, considering the usual value for the output filter, the LC resonance results to be at frequency lower than the above reported zero. Compensation network can be simply designed placing $\omega_Z = \omega_{LC}$ and imposing the cross-over frequency ω_T as desired obtaining:

$$R_F = \frac{R_{FB} \cdot \Delta V_{OSC}}{V_{IN}} \cdot \frac{5}{4} \cdot \omega_T \cdot \frac{L}{2 \cdot (R_{DROOP} + ESR)} \quad C_F = \frac{\sqrt{C_O \cdot \frac{L}{2}}}{R_F}$$

Figure 14. ACM Control Loop Gain Block Diagram (left) and Bode Diagram (right)

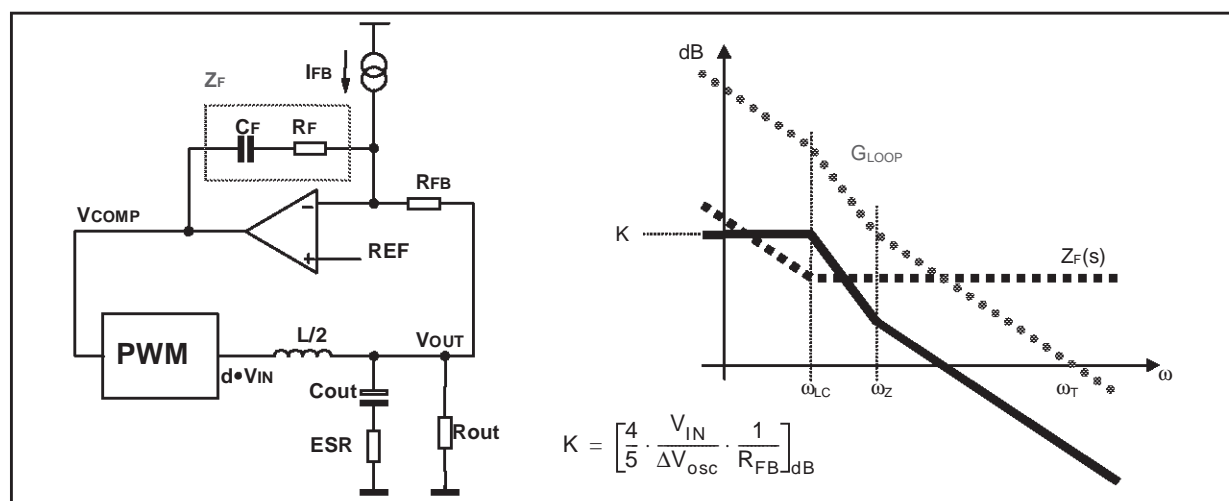

LAYOUT GUIDELINES

Since the device manages control functions and high-current drivers, layout is one of the most important things to consider when designing such high current applications.

A good layout solution can generate a benefit in lowering power dissipation on the power paths, reducing radiation and a proper connection between signal and power ground can optimize the performance of the control loops.

Integrated power drivers reduce components count and interconnections between control functions and drivers, reducing the board space.

Here below are listed the main points to focus on when starting a new layout and rules are suggested for a correct implementation.

■ **Power Connections.**

These are the connections where switching and continuous current flows from the input supply towards the load. The first priority when placing components has to be reserved to this power section, minimizing the length of each connection as much as possible.

To minimize noise and voltage spikes (EMI and losses) these interconnections must be a part of a power plane and anyway realized by wide and thick copper traces. The critical components, i.e. the power transistors, must be located as close as possible, together and to the controller. Considering that the "electrical" components reported in figure are composed by more than one "physical" component, a ground plane or "star" grounding connection is suggested to minimize effects due to multiple connections.

Figure 15. Power connections and related connections layout guidelines (same for both phases)

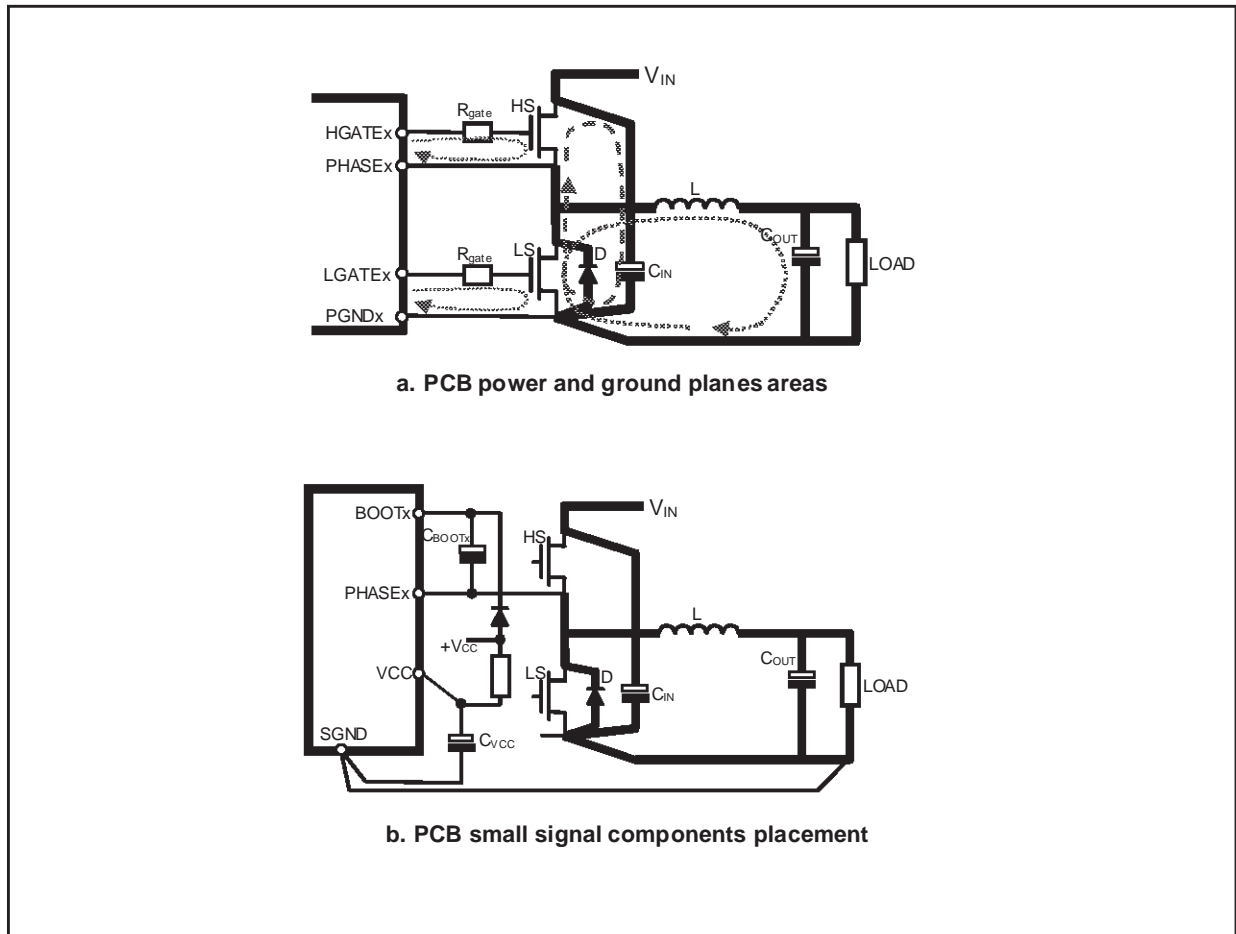

Fig. 15a shows the details of the power connections involved and the current loops. The input capacitance (C_{IN}), or at least a portion of the total capacitance needed, has to be placed close to the power section in order to eliminate the stray inductance generated by the copper traces. Low ESR and ESL capacitors are required.

■ Power Connections Related.

Fig.15b shows some small signal components placement, and how and where to mix signal and power ground planes. The distance from drivers and mosfet gates should be reduced as much as possible. Propagation delay times as well as for the voltage spikes generated by the distributed inductance along the copper traces are so minimized.

In fact, the further the mosfet is from the device, the longer is the interconnecting gate trace and as a consequence, the higher are the voltage spikes corresponding to the gate PWM rising and falling signals. Even if these spikes are clamped by inherent internal diodes, propagation delays, noise and potential causes of instabilities are introduced jeopardizing good system behavior. One important consequence is that the switching losses for the high side mosfet are significantly increased.

For this reason, it is suggested to have the device oriented with the driver side towards the mosfets and the GATEx and PHASEx traces walking together toward the high side mosfet in order to minimize distance (see fig 16). In addition, since the PHASEx pin is the return path for the high side driver, this pin must be connected directly to the High Side mosfet Source pin to have a proper driving for this mosfet. For the LS mosfets, the return path is the PGND pin: it can be connected directly to the power ground plane (if implemented) or in the same way to the LS mosfets Source pin. GATEx and PHASEx connections (and also PGND when no power ground plane is implemented) must also be designed to handle current peaks in excess of 2A (30 mils wide is suggested).

Gate resistors of few ohms help in reducing the power dissipated by the IC without compromising the system efficiency.

Figure 16. Device orientation (left) and sense nets routing (right)

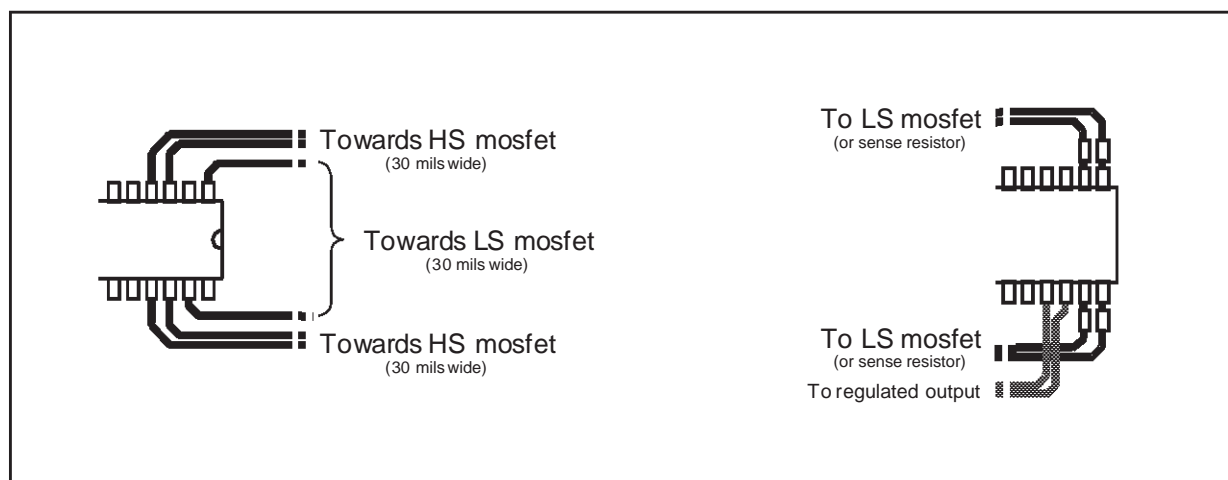

The placement of other components is also important:

- The bootstrap capacitor must be placed as close as possible to the BOOTx and PHASEx pins to minimize the loop that is created.
- Decoupling capacitor from Vcc and SGND placed as close as possible to the involved pins.
- Decoupling capacitor from VCCDR and PGND placed as close as possible to those pins. This capacitor sustains the peak currents requested by the low-side mosfet drivers.
- Refer to SGND all the sensible components such as frequency set-up resistor (when present) and also the optional resistor from FB to GND used to give the positive droop effect.
- Connect SGND to PGND on the load side (output capacitor) to avoid undesirable load regulation effect and to ensure the right precision to the regulation when the remote sense buffer is not used.

- An additional 100nF ceramic capacitor is suggested to place near HS mosfet drain. This helps in reducing noise.
- PHASE pin spikes. Since the HS mosfet switches in hard mode, heavy voltage spikes can be observed on the PHASE pins. If these voltage spikes overcome the max breakdown voltage of the pin, the device can absorb energy and it can cause damages. The voltage spikes must be limited by proper layout, the use of gate resistors, Schottky diodes in parallel to the low side mosfets and/or snubber network on the low side mosfets, to a value lower than 26V, for 20nSec, at FSW of 600kHz max.

■ **Current Sense Connections.**

Remote Buffer: The input connections for this components must be routed as parallel nets from the FBG/FBR pins to the load in order to compensate losses along the output power traces and also to avoid the pick-up of any common mode noise. Connecting these pins in points far from the load, will cause a non-optimum load regulation, increasing output tolerance.

Current Reading: The Rg resistor has to be placed as close as possible to the ISENx and PGNDsx pins in order to limit the noise injection into the device. The PCB traces connecting these resistors to the reading point must be routed as parallel traces in order to avoid the pick-up of any common mode noise. It's also important to avoid any offset in the measurement and to get a better precision, to connect the traces as close as possible to the sensing elements, dedicated current sense resistor or low side mosfet RdsON.

Moreover, when using the low side mosfet RdsON as current sense element, the ISENx pin is practically connected to the PHASEx pin. **DO NOT CONNECT THE PINS TOGETHER AND THEN TO THE HS SOURCE!** The device won't work properly because of the noise generated by the return of the high side driver. In this case route two separate nets: connect the PHASEx pin to the HS Source (route together with HGATEx) with a wide net (30 mils) and the ISENx pin to the LS Drain (route together with PGNDsx). Moreover, the PGNDsx pin is always connected, through the Rg resistor, to the PGND: **DO NOT CONNECT DIRECTLY TO THE PGND!** In this case the device won't work properly. Route anyway to the LS mosfet source (together with ISENx net).

Right and wrong connections are reported in Figure 17.

Symmetrical layout is also suggested to avoid any unbalance between the two phases of the converter.

Figure 17. PCB layout connections for sense nets

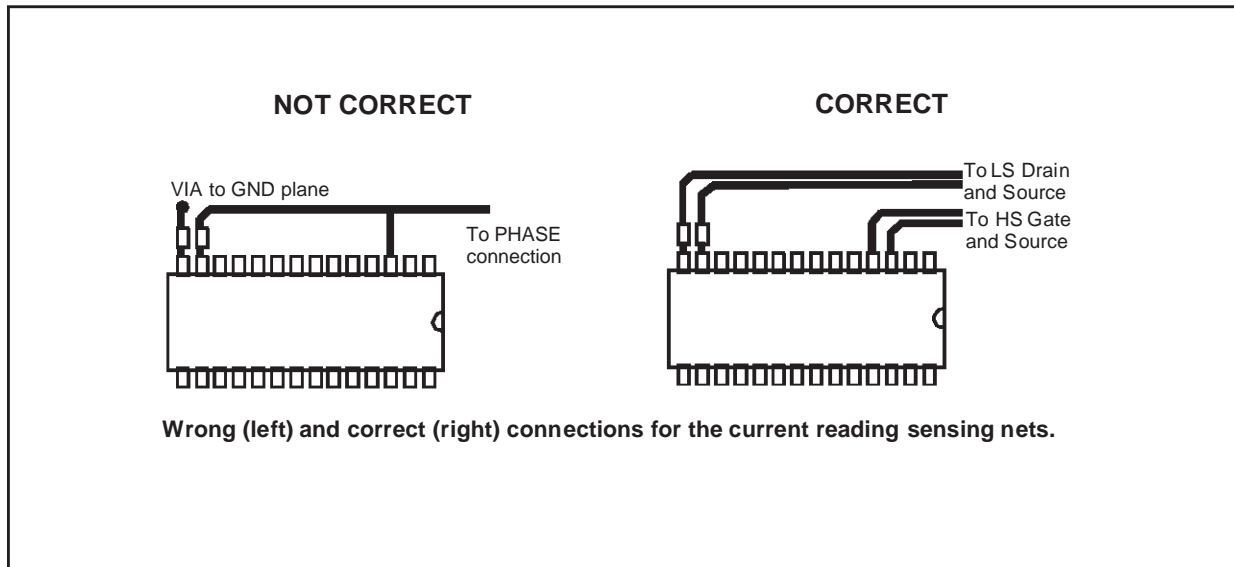

Demo Board Description

The L6919C demo board shows the operation of the device in a dual phase application. This evaluation board allows output voltage adjustability (0.800V - 1.550V) through the switches S0-S4 and high output current capability.

The board has been laid out with the possibility to use up to two D²PACK mosfets for the low side switch in order to give maximum flexibility in the mosfet choice.

The four layers demo board's copper thickness is of 70µm in order to minimize conduction losses considering the high current that the circuit is able to deliver.

Demo board schematic circuit is reported in Figure 18.

Figure 18. Demo Board Schematic

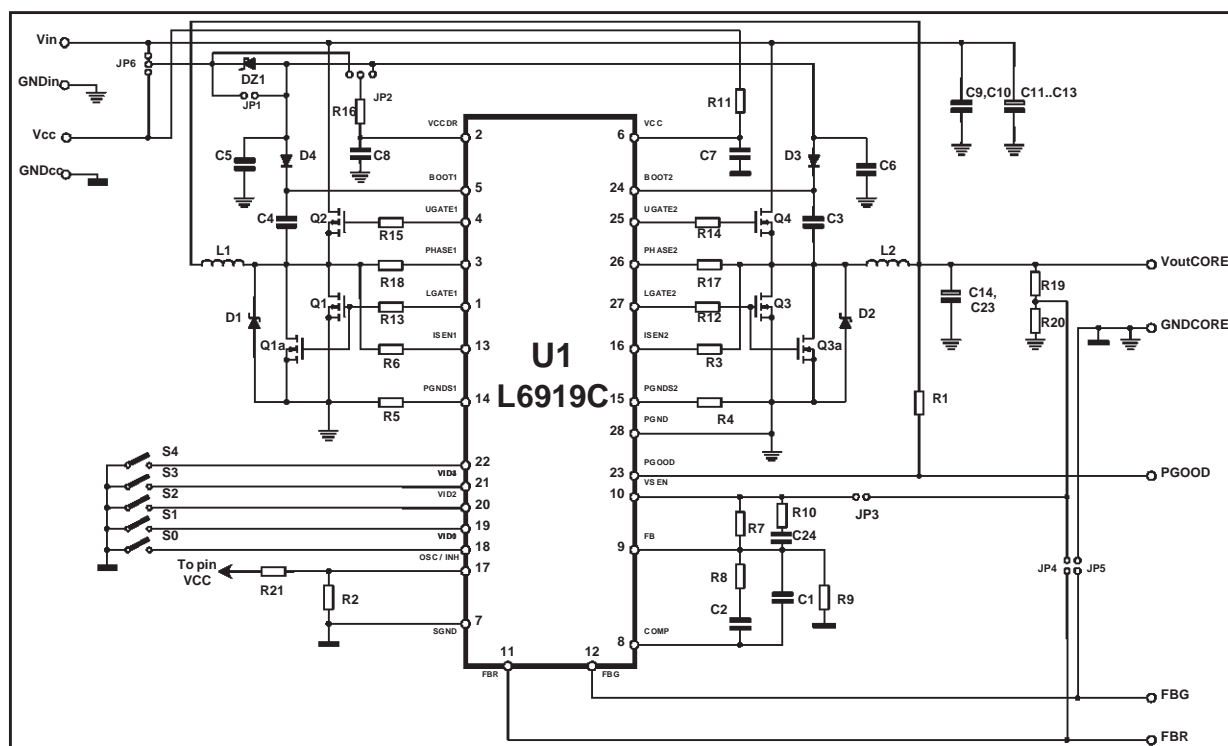

Several jumpers allow setting different configurations for the device: JP3, JP4 and JP5 allow configuring the remote buffer as desired. Simply shorting JP4 and JP5 the remote buffer is enabled and it senses the output voltage on-board; to implement a real remote sense, leave these jumpers open and connect the FBG and FBR connectors on the demo board to the remote load. To avoid using the remote buffer, simply short all the jumpers JP3, JP4 and JP5. Local sense through the R7 is used for the regulation.

The input can be configured in different ways using the jumpers JP1, JP2 and JP6; these jumpers control also the mosfet driver supply voltage. Anyway, power conversion starts from V_{IN} and the device is supplied from V_{CC} (See Figure 19).

Figure 19. Power supply configuration

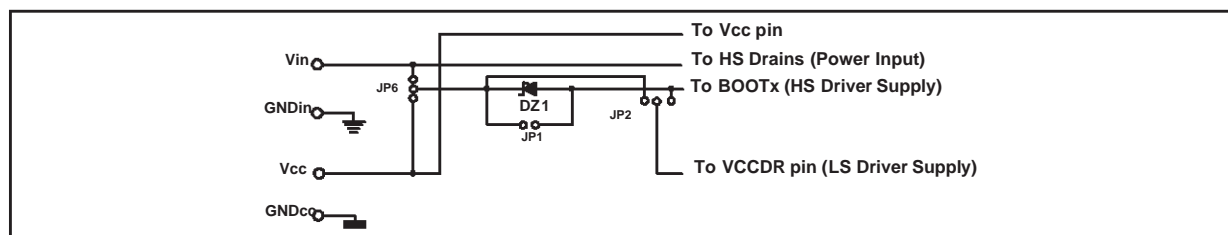

Two main configurations can be distinguished: Single Supply ($V_{CC}=V_{IN}=12V$) and Double Supply ($V_{CC}=12V$ $V_{IN}=5V$ or different).

- Single Supply: In this case JP6 has to be completely shorted. The device is supplied with the same rail that is used for the conversion. With an additional zener diode DZ1 a lower voltage can be derived to supply the mosfets driver if Logic level mosfet are used. In this case JP1 must be left open so that the HS driver is supplied with $V_{IN}-V_{DZ1}$ through BOOTx and JP2 must be shorted to the left to use V_{IN} or to the right to use $V_{IN}-V_{DZ1}$ to supply the LS driver through VCCDR pin. Otherwise, JP1 must be shorted and JP2 can be freely shorted in one of the two positions.
- Double Supply: In this case VCC supply directly the controller (12V) while V_{IN} supplies the HS drains for the power conversion. This last one can start indifferently from the 5V bus (Typ.) or from other buses allowing maximum flexibility in the power conversion. Supply for the mosfet driver can be programmed through the jumpers JP1, JP2 and JP6 as previously illustrated. JP6 selects now V_{CC} or V_{IN} depending on the requirements.

Some examples are reported in the following Figures 20 and 21.

Figure 20. Jumpers configuration: Double Supply

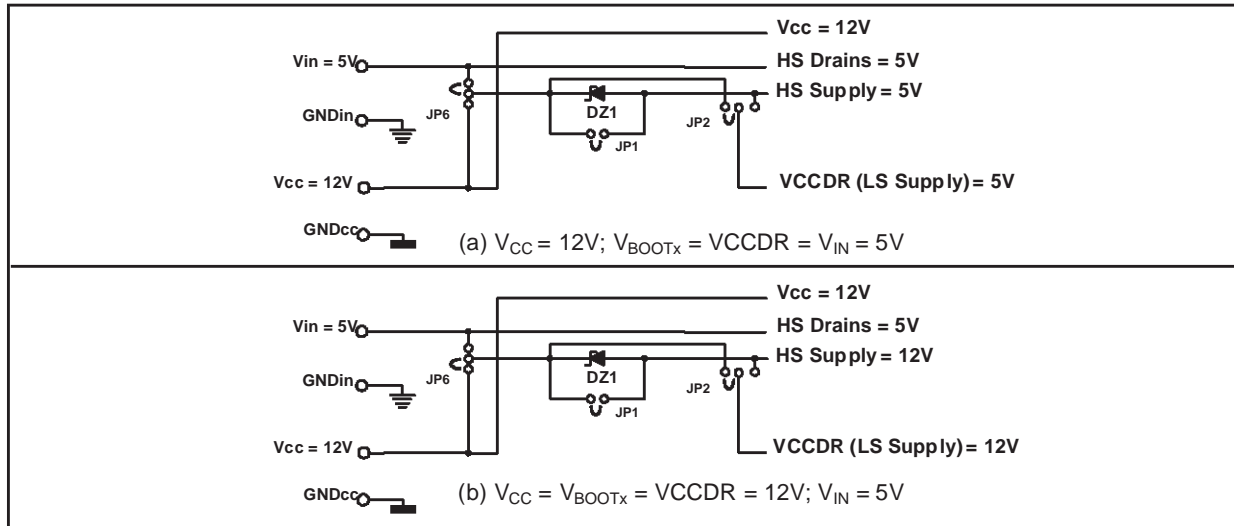
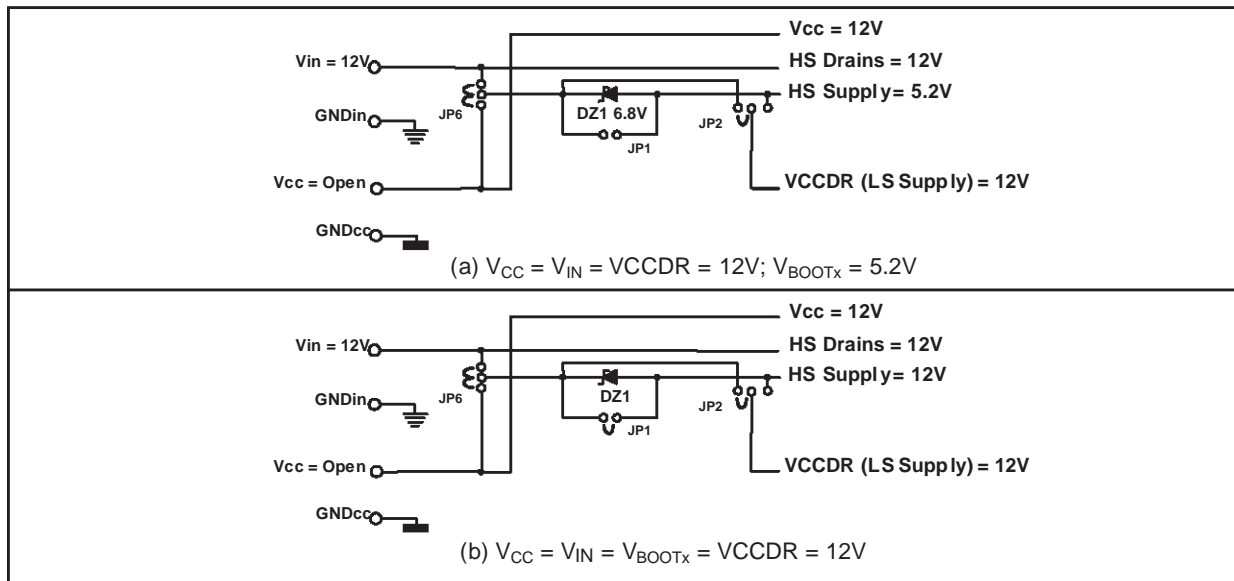
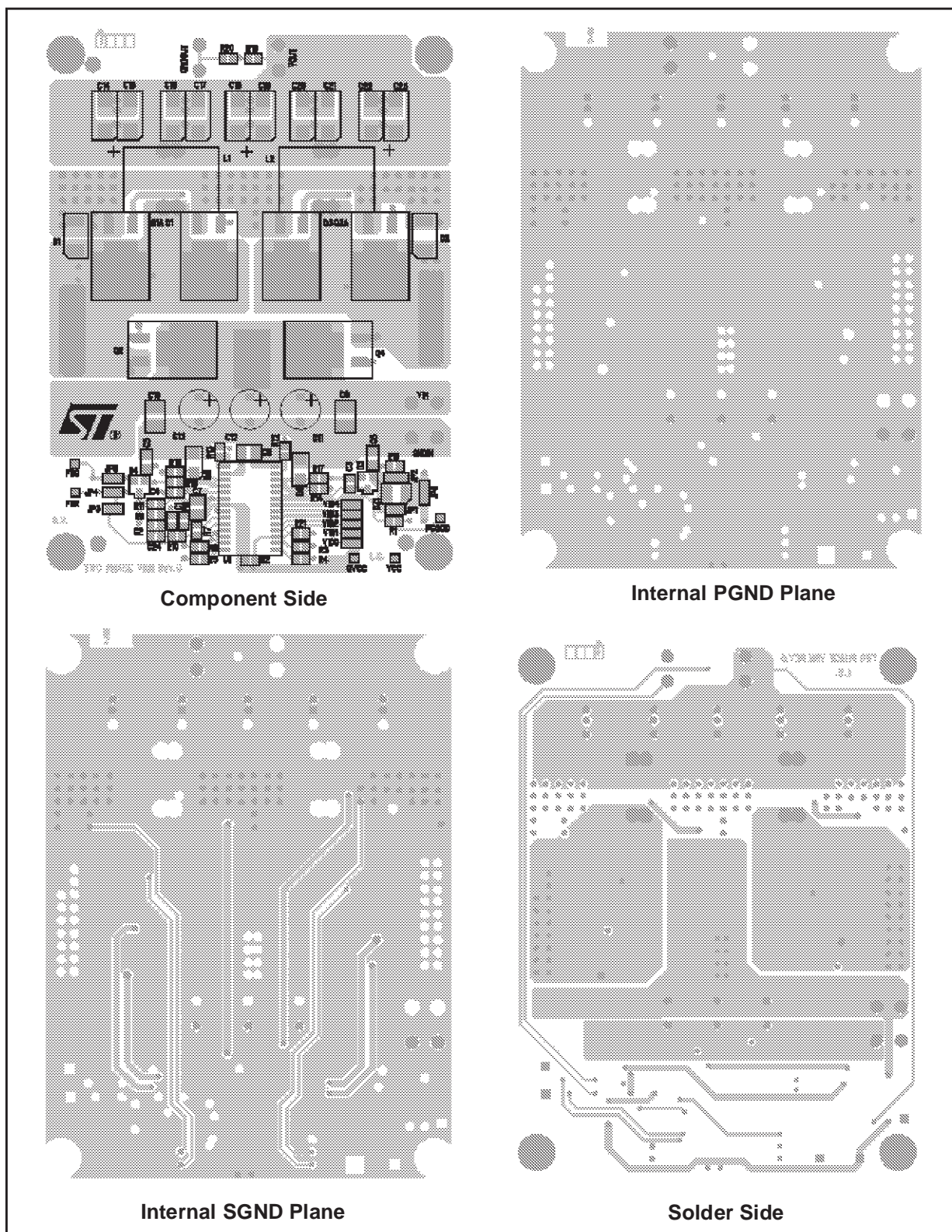

Figure 21. Jumpers configuration: Single Supply



PCB AND COMPONENT LAYOUT

Figure 22. PCB and Components Layouts (Dimensions: 10.8mm x 8.2mm)



CPU Power Supply: 5 to 12V_{IN}; 1.2V_{OUT}; 45A_{DC}

Considering the high slope for the load transient, a high switching frequency has to be used. In addition to fast reaction, this helps in reducing output and input capacitor. Inductance value is also reduced.

A switching frequency of 200kHz for each phase is then considered allowing large bandwidth for the compensation network. Considering the high output current, power conversion will start from the 12V bus.

– Current Reading Network and Over Current:

Since the maximum output current is $I_{MAX} = 45A$, the over current threshold has been set to 45A (22.5A x 2) in the worst case (max mosfet temperature). Since the device limits the valley of the triangular ripple across the inductors, the current ripple must be considered too. Considering the inductor core saturation, a current ripple of 10A has to be considered so that the OCP threshold in worst case becomes $OCP_x = 17A$ (22.5A-5A). Considering to sense the output current across the low-side mosfet R_{dsON} , SUB85N03L-04P has 4.3mΩ max at 25°C that becomes 5.6mΩ at 100°C considering the temperature variation; the resulting transconductance resistor R_g has to be:

$$R_g = I_{OCPx} \cdot \frac{R_{dsON}}{35\mu} = 17 \cdot \frac{5.6m}{35\mu} = 2.7k\Omega \quad (R3 \text{ to } R6)$$

– Droop function Design:

Considering a voltage drop of 70mV at full load, the feedback resistor R_B has to be:

$$R_{FB} = \frac{70mV}{70\mu A} = 1k\Omega \quad (R7)$$

– Inductor design:

Transient response performance needs a compromise in the inductor choice value: the biggest the inductor, the highest the efficient but the worse the transient response and vice versa.

Considering then an inductor value of 0.8μH, the current ripple becomes:

$$\Delta I = \frac{V_{in} - V_{out}}{L} \cdot \frac{d}{F_{sw}} = \frac{12 - 1.2}{0.8\mu} \cdot \frac{1.2}{12} \cdot \frac{1}{200k} = 6.5A \quad (L1, L2)$$

– Output Capacitor:

Five Rubycon MBZ (2200μF / 6.3V / 12mΩ max ESR) has been used implementing a resulting ESR of 2.4mΩ resulting in an ESR voltage drop of 45A · 2.4mΩ = 108mV after a 45A load transient.

– Compensation Network:

A voltage loop bandwidth of 20kHz is considered to let the device fast react after load transient.

The $R_F C_F$ network results:

$$R_F = \frac{R_{FB} \cdot \Delta V_{OS}}{V_{IN}} \cdot \frac{5}{4} \cdot \omega_T \cdot \frac{L}{2 \cdot (R_{DROOP} + ESR)} = \frac{1K \cdot 2}{12} \cdot \frac{5}{4} \cdot 20K \cdot 2\pi \cdot \frac{0.8\mu}{2 \cdot \left(\frac{5.6m}{2.7} \cdot 1.2k + 2.4m\right)} = 2.0k\Omega \quad (R8)$$

$$C_F = \frac{\sqrt{C_o \cdot \frac{L}{2}}}{R_F} = \frac{\sqrt{6 \cdot 2200\mu \cdot \frac{1\mu}{2}}}{2k} = 33nF \quad (C2)$$

Further adjustments can be done on the work bench to fit the requirements and to compensate layout parasitic components.

Part List

R1	10k		SMD 0805
R2, R20,R21	Not Mounted		SMD 0805
R3, R4, R5, R6	2.7k	1%	SMD 0805
R7	1k	1%	SMD 0805
R8	1.8k		SMD 0805
R9	47k	1%	SMD 0805
R10	510		SMD 0805
R11	82		SMD 0805
R12 to R19	0		SMD 0805
C1	Not Mounted		SMD 0805
C2	22n		SMD 0805
C3, C4	100n		SMD 0805
C5, C6, C7, C8	1 μ	Ceramic	SMD 1206
C9, C10	10 μ or 22 μ / 16V	TDK Multilayer Ceramic	SMD 1206
C11 to C13	1800 μ / 16V	Rubycon MBZ	Radial 10x23
C14 to C18	2200 μ / 6.3V	Rubycon MBZ	Radial 10x20
C24	100n		SMD 0805
L1, L2	0.8 μ	77121 - 4Turns	
U1	L6919C	STMicroelectronics	SO28
Q1, Q3	SUB85N03-04P	Vishay	D ² PACK
Q2, Q4	SUB70N03-09BP	Vishay	D ² PACK
D1, D2	STPS340U	STMicroelectronics	SMB
D3, D4	1N4148	STMicroelectronics	SOT23
S0,S4	Short		
S1,S2,S3	Open		

STATIC PERFORMANCES

Figure 23 shows the demo board measured efficiency versus load current in steady state conditions without air-flow at ambient temperature.

Figure 23. System Efficiency

Figure 24 shows the mosfets temperature versus output current in steady state condition without any air-flow or heat sink. It can be observed that the mosfets are under 100°C in any conditions. Load regulation is also reported from 10A to 45A.

Figure 24. Mosfet Temperature and Load Regulation

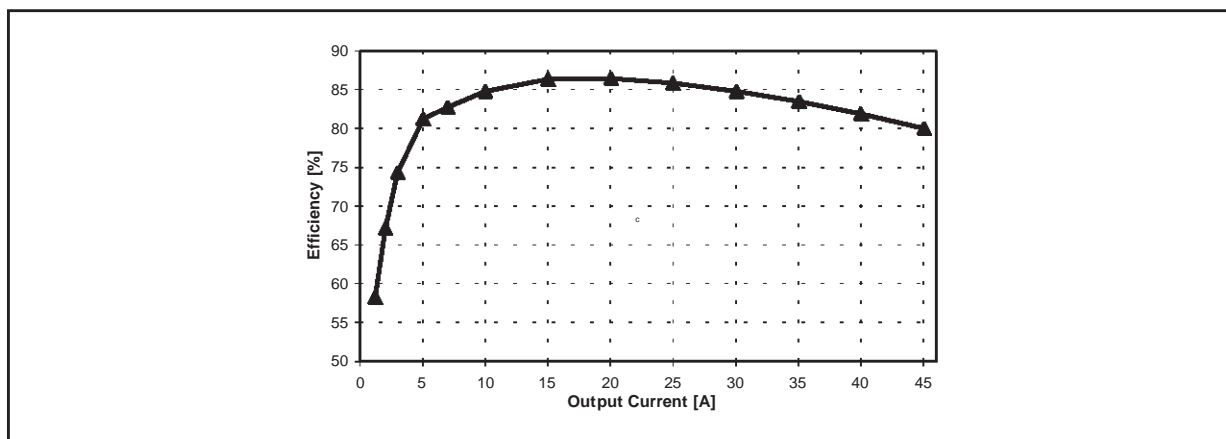
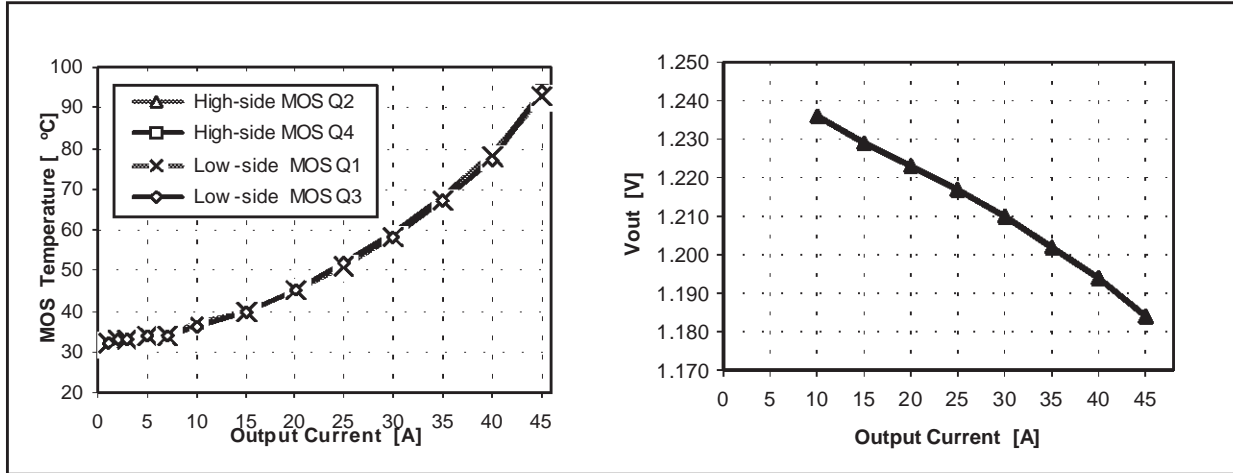

DYNAMIC PERFORMANCES

Figure 25 shows the system response to a load transient from 3A to 45A. The output voltage is contained in the ±50mV range. Additional output capacitors can help in reducing the initial voltage spike mainly due to the ESR.

Figure 25. 3A to 45A Load Transient Response

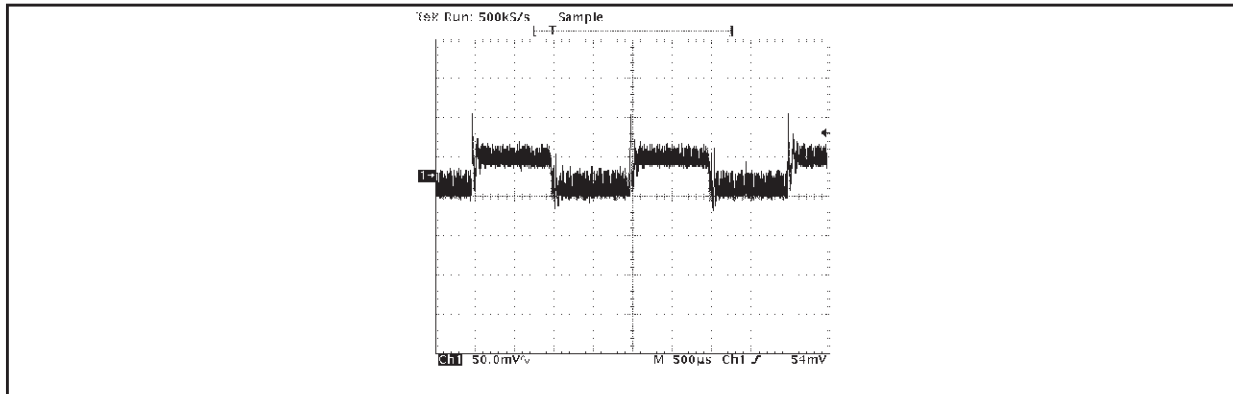
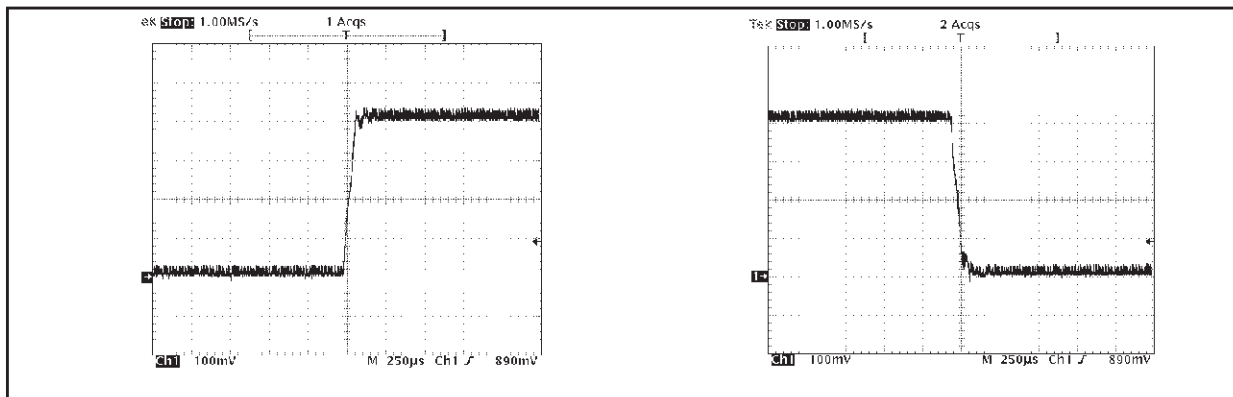

Figure 26 shows the system response to a VID transient from 1.200V to 0.800V and vice versa at minimum load (3A).

Figure 26. Dynamic VID Response



DEMO BOARD ENHANCEMENTS: 1.200V / 52A CPU Power Supply

Considering the same application schematic, minor changes can be done to achieve the 52A thermal output current required by AMD Hammer processor core. Part list has been modified as follow:

Part List

R1, R2, R20,R21	Not Mounted		SMD 0805
R3, R4, R5, R6	1.5k	1%	SMD 0805
R7	1k	1%	SMD 0805
R8	1.8k		SMD 0805
R9	47k	1%	SMD 0805
R10	510		SMD 0805
R11	82		SMD 0805
R12 to R19	0		SMD 0805
C1	Not Mounted		SMD 0805
C2	10n		SMD 0805
C3, C4	100n		SMD 0805
C5, C6, C7, C8	1 μ	Ceramic	SMD 1206
C9, C10	10 μ or 22 μ / 16V	TDK Multilayer Ceramic	SMD 1206
C11 to C13	1800 μ / 16V	Rubycon MBZ	Radial 10x23
C14 to C18	2200 μ / 6.3V	Rubycon MBZ	Radial 10x20
C24	100n		SMD 0805
L1, L2	0.8 μ	77121 - 4Turns	
U1	L6919C	STMicroelectronics	SO28
Q1, Q1a, Q3, Q3a	SUB85N03-04P	Vishay-Siliconix	D ² PACK
Q2, Q4	SUB70N03-09BP	Vishay-Siliconix	D ² PACK
D1, D2	STPS340U	STMicroelectronics	SMB
D3, D4	1N4148	STMicroelectronics	SOT23
S0,S4	Short		
S1,S2,S3	Open		

STATIC PERFORMANCES

Figure 27 shows the demo board measured efficiency versus load current in steady state conditions without air-flow at ambient temperature.

Figure 27. System Efficiency

Figure 28 shows the mosfets temperature versus output current in steady state condition without any air-flow or heat sink. It can be observed that the mosfets are under 105°C in any conditions. Load regulation is also reported from 10A to 55A.

Figure 28. Mosfet Temperature and Load Regulation.

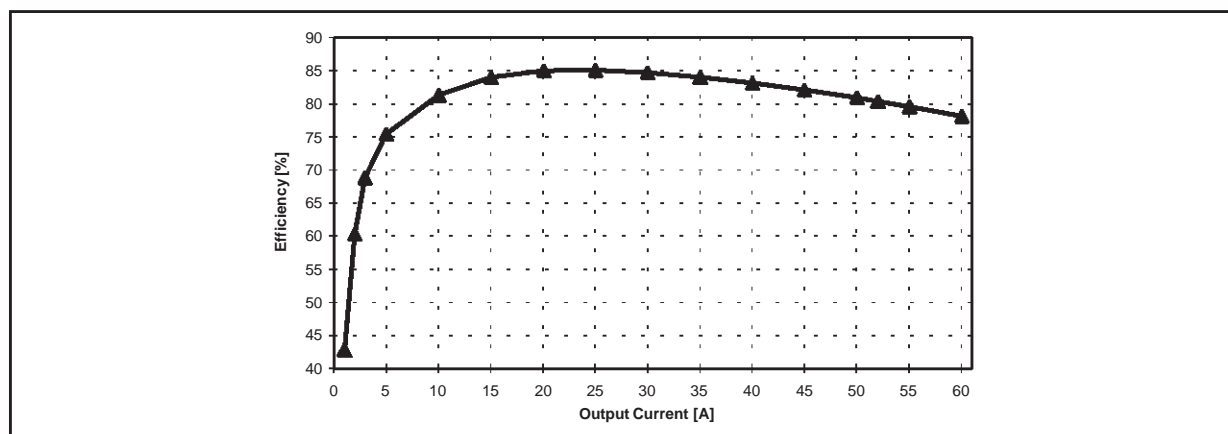
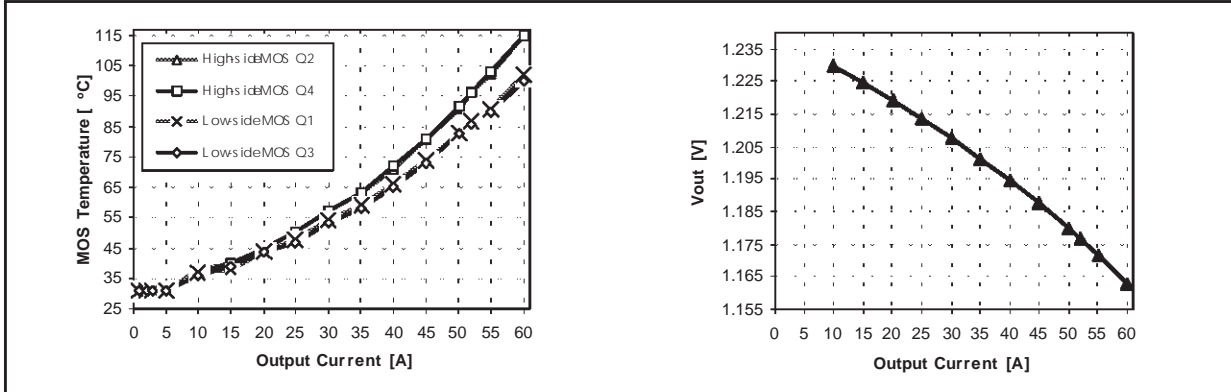

Figure 29 shows the system response to a load transient from 3A to 45A. The output voltage is contained in the $\pm 50\text{mV}$ range. Additional output capacitors can help in reducing the initial voltage spike mainly due to the ESR.

Figure 29. 3A to 45A Load Transient Response

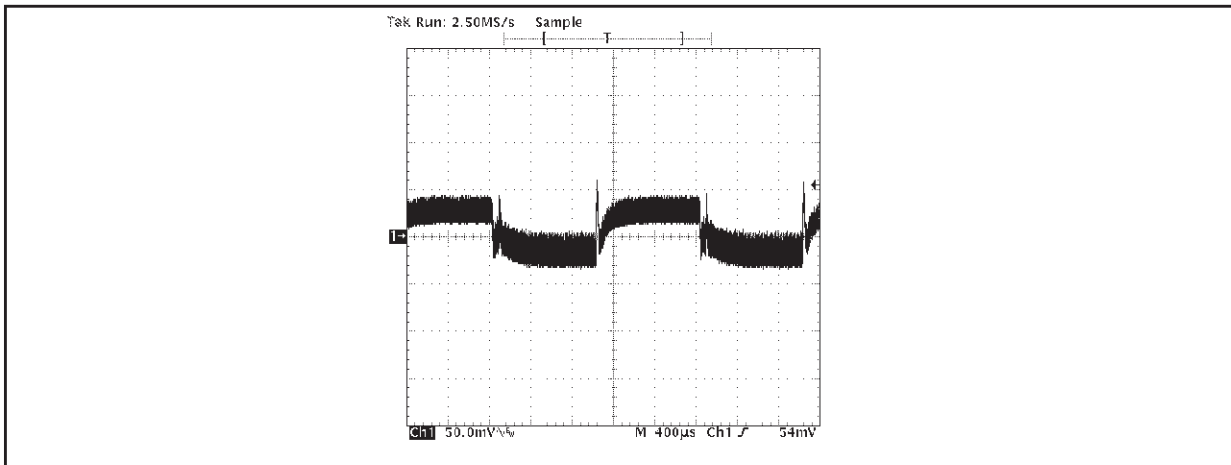
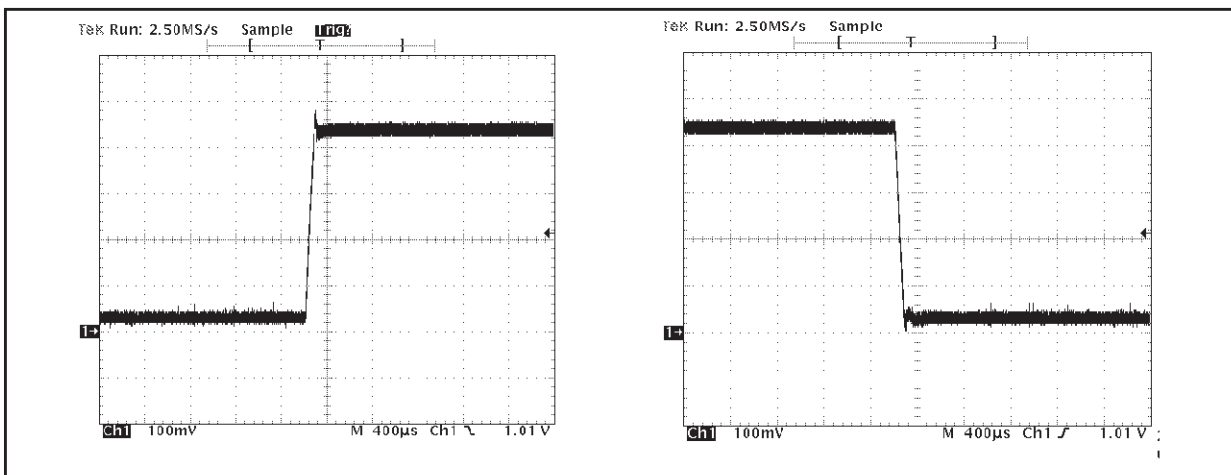

Figure 30 shows the system response to a VID transient from 1.200V to 0.800V and vice versa at minimum load (3A).

Figure 30. Dynamic VID Response



DIM.	mm			inch		
	MIN.	TYP.	MAX.	MIN.	TYP.	MAX.
A			2.65			0.104
a1	0.1		0.3	0.004		0.012
b	0.35		0.49	0.014		0.019
b1	0.23		0.32	0.009		0.013
C		0.5			0.020	
c1	45° (typ.)					
D	17.7		18.1	0.697		0.713
E	10		10.65	0.394		0.419
e		1.27			0.050	
e3		16.51			0.65	
F	7.4		7.6	0.291		0.299
L	0.4		1.27	0.016		0.050
S	8° (max.)					

OUTLINE AND MECHANICAL DATA

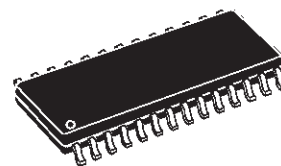

SO28

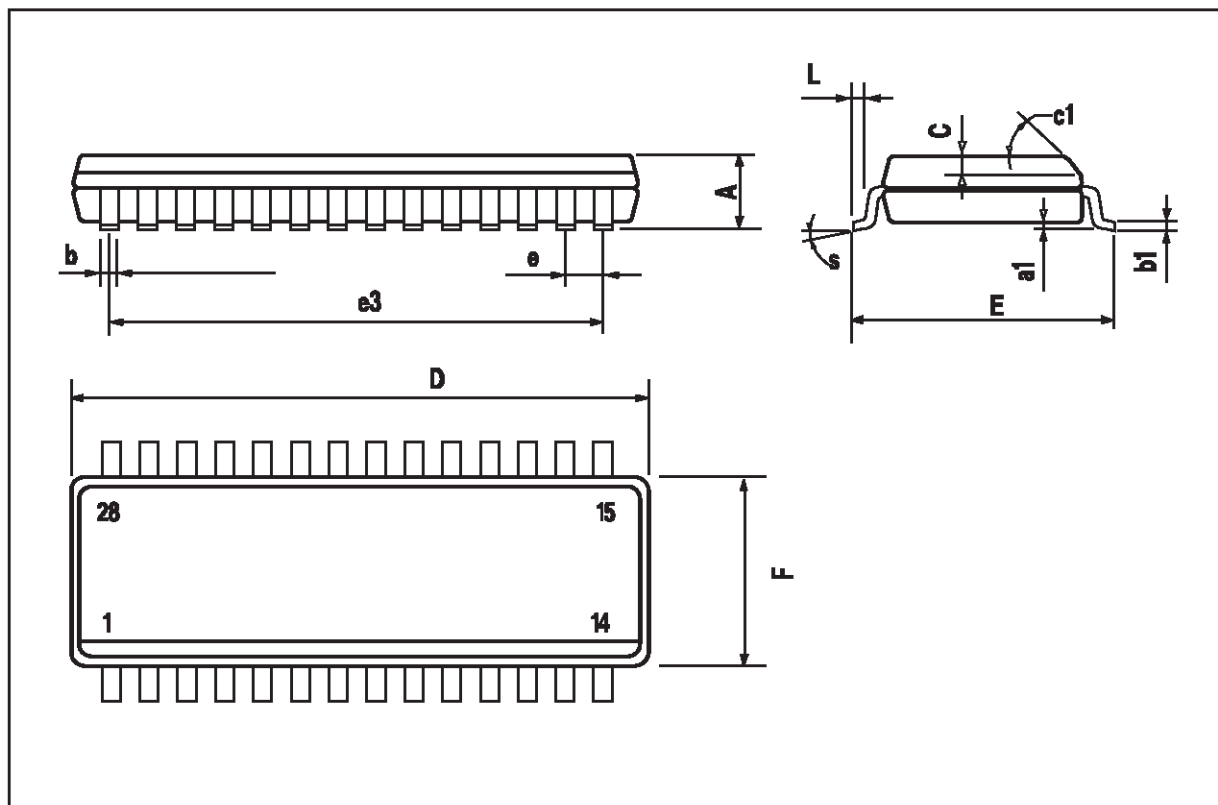

Information furnished is believed to be accurate and reliable. However, STMicroelectronics assumes no responsibility for the consequences of use of such information nor for any infringement of patents or other rights of third parties which may result from its use. No license is granted by implication or otherwise under any patent or patent rights of STMicroelectronics. Specifications mentioned in this publication are subject to change without notice. This publication supersedes and replaces all information previously supplied. STMicroelectronics products are not authorized for use as critical components in life support devices or systems without express written approval of STMicroelectronics.

The ST logo is a registered trademark of STMicroelectronics
© 2002 STMicroelectronics - All Rights Reserved

STMicroelectronics GROUP OF COMPANIES
Australia - Brazil - Canada - China - Finland - France - Germany - Hong Kong - India - Israel - Italy - Japan -Malaysia - Malta - Morocco -
Singapore - Spain - Sweden - Switzerland - United Kingdom - United States.
<http://www.st.com>