

74ABT126 Quad Buffer with TRI-STATE® Outputs

General Description

The 74ABT126 contains four independent non-inverting buffers with TRI-STATE outputs.

Features

- Non-inverting buffers
- Output sink capability of 64 mA, source capability of 32 mA

- Guaranteed latchup protection
- High impedance glitch free bus loading during entire power up and power down cycle
- Nondestructive hot insertion capability
- Disable time less than enable time to avoid bus contention

Commercial	Package Number	Package Description
74ABT126CSC (Note 1)	M14D	14-Lead (0.150" Wide) Molded Small Outline, JEDEC
74ABT126CSJ (Note 1)	M14D	14-Lead (0.300" Wide) Molded Small Outline, EIAJ
74ABT126CMTX (Notes 1, 2)	MTC14	14-Lead Molded Thin Shrink Small Outline, JEDEC

Note 1: Devices also available in 13" reel. Use suffix = SCX, SJX and MTCX.

Note 2: Contact factory for package availability

Connection Diagram

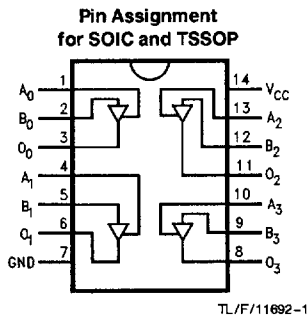

Pin Names	Description
A_n, B_n	Inputs
O_n	Outputs

Function Table

Inputs		Output
A_n	B_n	O_n
H	L	L
H	H	H
L	X	Z

H = HIGH Voltage Level
L = LOW Voltage Level
Z = HIGH Impedance
X = Immaterial

TRI-STATE® is a registered trademark of National Semiconductor Corporation

Absolute Maximum Ratings (Note 1)

Storage Temperature	-65°C to +150°C
Ambient Temperature under Bias	-55°C to +125°C
Junction Temperature under Bias Plastic	-55°C to +150°C
V _{CC} Pin Potential to Ground Pin	-0.5V to +7.0V
Input Voltage (Note 2)	-0.5V to +7.0V
Input Current (Note 2)	-30 mA to +5.0 mA
Voltage Applied to Any Output in the Disabled or Power-Off State in the HIGH State	-0.5V to 5.5V -0.5V to V _{CC}
Current Applied to Output in LOW State (Max)	twice the rated I _{OL} (mA)

DC Latchup Source Current (Across Comm Operating Range)	-500 mA A -300 mA
Over Voltage Latchup (I/O)	10V

Note 1: Absolute maximum ratings are values beyond which the device may be damaged or have its useful life impaired. Functional operation under these conditions is not implied.

Note 2: Either voltage limit or current limit is sufficient to protect inputs.

Recommended Operating Conditions

Free Air Ambient Temperature Commercial	-40°C to +85°C
Supply Voltage Commercial	+4.5V to +5.5V
Minimum Input Edge Rate Data Input	(ΔV/Δt) 50 mV/ns
Enable Input	100 mV/ns

DC Electrical Characteristics

Symbol	Parameter	ABT126			Units	V _{CC}	Conditions
		Min	Typ	Max			
V _{IH}	Input HIGH Voltage	2.0			V		Recognized HIGH Signal
V _{IL}	Input LOW Voltage			0.8	V		Recognized LOW Signal
V _{CD}	Input Clamp Diode Voltage			-1.2	V	Min	I _{IN} = -18 mA
V _{OH}	Output HIGH Voltage	74ABT	2.5		V	Min	I _{OH} = -3 mA
		74ABT	2.0		V	Min	I _{OH} = -32 mA
V _{OL}	Output LOW Voltage	74ABT		0.55	V	Min	I _{OL} = 64 mA
I _{IH}	Input HIGH Current			5 5	μA	Max	V _{IN} = 2.7V (Note 2) V _{IN} = V _{CC}
I _{BVI}	Input HIGH Current Breakdown Test			7	μA	Max	V _{IN} = 7.0V
I _{IL}	Input LOW Current			-5 -5	μA	Max	V _{IN} = 0.5V (Note 2) V _{IN} = 0.0V
V _{ID}	Input Leakage Test	4.75			V	0.0	I _{ID} = 1.9 μA, All Other Pins Grounded
I _{OZH}	Output Leakage Current			50	μA	0 - 5.5V	V _{OUT} = 2.7V; \overline{OE}_n = 2.0V
I _{OZL}	Output Leakage Current			-50	μA	0 - 5.5V	V _{OUT} = 0.5V; \overline{OE}_n = 2.0V
I _{OS}	Output Short-Circuit Current	-100		-275	mA	Max	V _{OUT} = 0.0V
I _{CEX}	Output High Leakage Current			50	μA	Max	V _{OUT} = V _{CC}
I _{ZZ}	Bus Drainage Test			100	μA	0.0	V _{OUT} = 5.5V; All Others GND
I _{CCH}	Power Supply Current			50	μA	Max	All Outputs HIGH
I _{CCL}	Power Supply Current			15	mA	Max	All Outputs LOW
I _{CCZ}	Power Supply Current			50	μA	Max	\overline{OE}_n = V _{CC} ; All Others at V _{CC} or Ground
I _{CCT}	Additional I _{CC} /Input	Outputs Enabled Outputs TRI-STATE Outputs TRI-STATE		1.5 1.5 50	mA mA μA	Max	V _I = V _{CC} - 2.1V Enable Input V _I = V _{CC} - 2.1V Data Input V _I = V _{CC} - 2.1V All Others at V _{CC} or Ground
I _{CCD}	Dynamic I _{CC} (Note 2)	No Load		0.1	mA/ MHz	Max	Outputs Open \overline{OE}_n = GND, (Note 1) One Bit Toggling, 50% Duty Cycle

Note 1: For 8 bits toggling, I_{CCD} < 0.8 mA/MHz.

Note 2: Guaranteed, but not tested.

AC Electrical Characteristics (SOIC and SSOP package)

Symbol	Parameter	74ABT			74ABT		Units
		T _A = +25°C V _{CC} = +5V C _L = 50 pF			T _A = -40°C to +85°C V _{CC} = 4.5V-5.5V C _L = 50 pF		
		Min	Typ	Max	Min	Max	
t _{PLH}	Propagation Delay	1.0		4.4	1.0	4.4	ns
t _{PHL}	Data to Outputs	1.0		4.6	1.0	4.6	
t _{PZH}	Output Enable	1.0		6.5	1.0	6.5	ns
t _{PZL}	Time	1.0		6.5	1.0	6.5	
t _{PHZ}	Output Disable	1.0		5.8	1.0	5.8	ns
t _{PLZ}	Time	1.0		5.5	1.0	5.5	

Capacitance

Symbol	Parameter	Typ	Units	Conditions T _A = 25°C
C _{IN}	Input Capacitance	5.0	pF	V _{CC} = 0V
C _{OUT} (Note 1)	Output Capacitance	9.0	pF	V _{CC} = 5.0V

Note 1: C_{OUT} is measured at frequency f = 1 MHz, per MIL-STD-883B, Method 3012

Ordering Information

The device number is used to form part of a simplified purchasing code where the package type and temperature range are defined as follows:

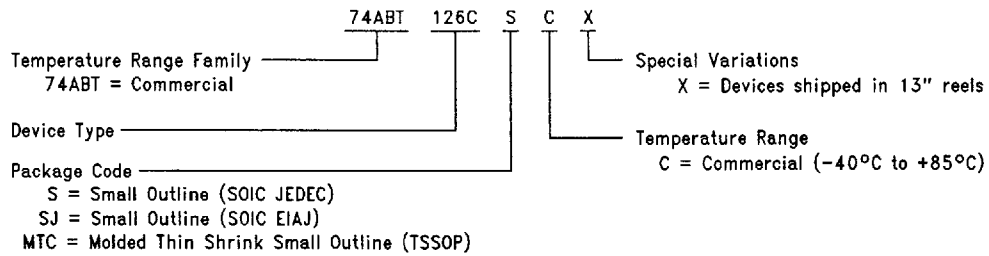

TL/F/11692-3

Physical Dimensions inches (millimeters) (Continued)

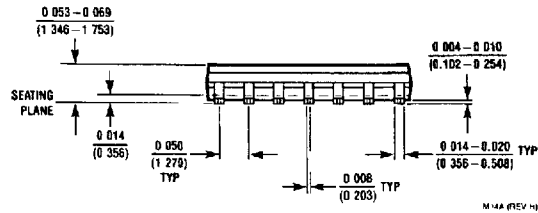
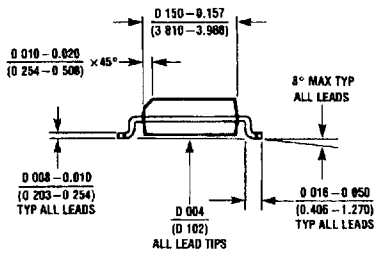
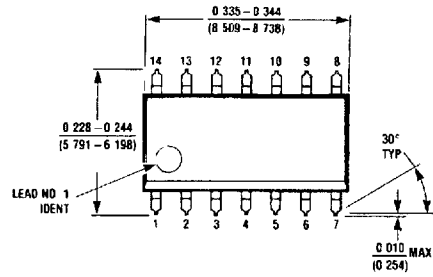

14-Lead Small Outline Integrated Circuit (S)
NS Package Number M14A

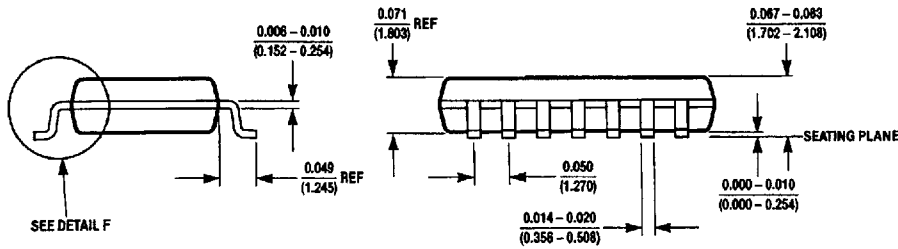
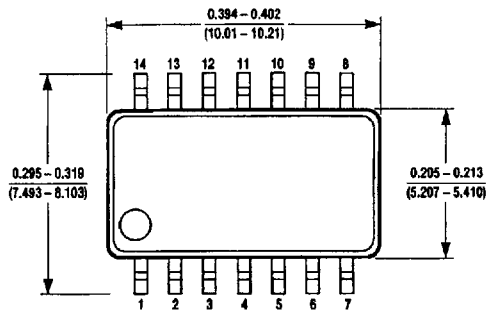
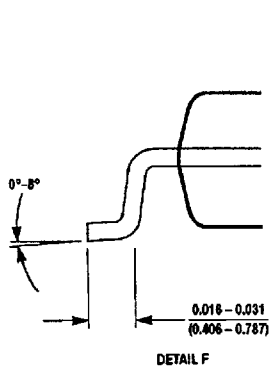

14-Lead Small Outline Package—EIAJ (SJ)
NS Package Number M14D

Physical Dimensions millimeters (Continued)

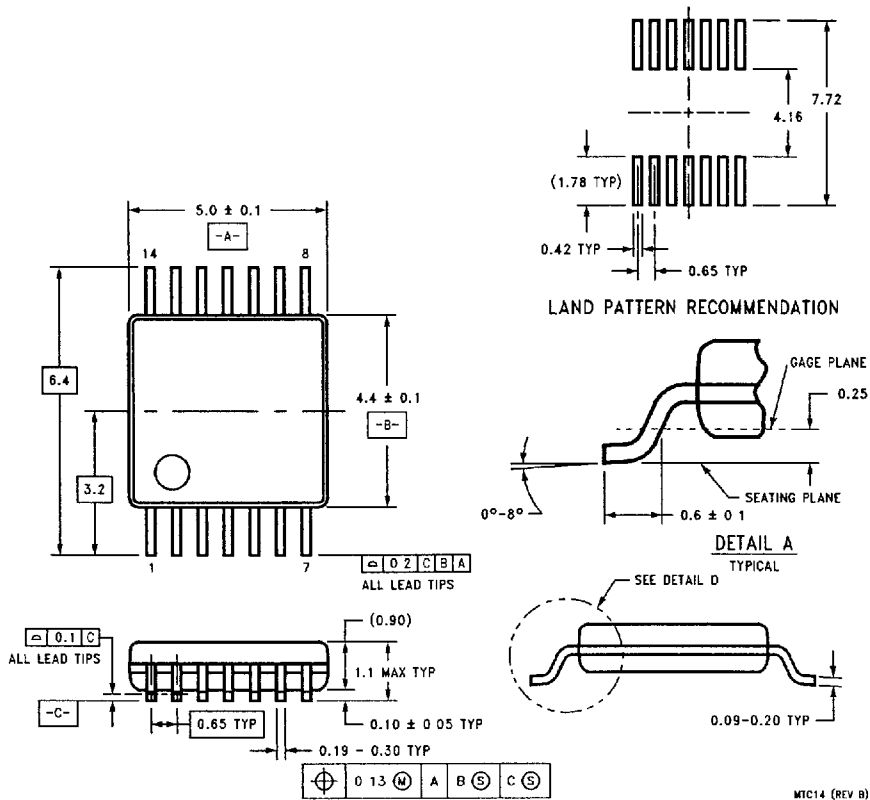

**14-Lead Molded Thin Shink Small Outline Package, JEDEC
NS Package Number MTC14**

LIFE SUPPORT POLICY

NATIONAL'S PRODUCTS ARE NOT AUTHORIZED FOR USE AS CRITICAL COMPONENTS IN LIFE SUPPORT DEVICES OR SYSTEMS WITHOUT THE EXPRESS WRITTEN APPROVAL OF THE PRESIDENT OF NATIONAL SEMICONDUCTOR CORPORATION. As used herein:

1. Life support devices or systems are devices or systems which, (a) are intended for surgical implant into the body, or (b) support or sustain life, and whose failure to perform, when properly used in accordance with instructions for use provided in the labeling, can be reasonably expected to result in a significant injury to the user.
2. A critical component is any component of a life support device or system whose failure to perform can be reasonably expected to cause the failure of the life support device or system, or to affect its safety or effectiveness.

National Semiconductor Corporation
1111 West Bardin Road
Arlington, TX 78017
Tel 1(800) 272-9959
Fax: 1(800) 737-7018

National Semiconductor Europe
Fax: (+49) 0-180-530 85 86
Email: crpwge@tevm2.nsc.com
Deutsch Tel: (+49) 0-180-530 85 85
English Tel: (+49) 0-180-532 78 32
Français Tel: (+49) 0-180-532 93 58
Italiano Tel: (+49) 0-180-534 16 80

National Semiconductor Hong Kong Ltd.
13th Floor, Straight Block,
Ocean Centre, 5 Canton Rd
Tsimshatsui, Kowloon
Hong Kong
Tel (852) 2737-1600
Fax (852) 2736-9960

National Semiconductor Japan Ltd.
Tel 81-043-299-2309
Fax 81-043-299-2408

National does not assume any responsibility for use of any circuitry described, no circuit patent licenses are implied and National reserves the right at any time without notice to change said circuitry and specifications.