

MOSEL

MOSEL-VITELIC

MS6264A**8K x 8 High Speed CMOS Static RAM**

Preliminary

T-46-23-12

2

FEATURES

- High-speed – 20/25/30 ns
- Low Power dissipation:
 - 825mW (Max.) Operating
 - 550 μ W (Max.) Power Down
 - 50 μ A (Max.) I_{CCDR}
- 5V \pm 10% supply
- Fully static operation
- TTL compatible I/O
- Three state outputs
- Ultra low data retention supply current at $V_{CC} = 2V$
- Pin compatible with 64K bit EPROM

DESCRIPTION

The MOSEL MS6264A is a 65,536-bit static random access memory organized as 8,192 words by 8 bits and operates from a single 5 volt supply. It is built with MOSEL's high performance twin tub CMOS process. Inputs and three-state outputs are TTL compatible and allow for direct interfacing with common system bus structures. The MS6264A is available in the following standard 28-pin packages:

- 600 MIL Plastic DIP
- 300 MIL Plastic DIP
- 300 MIL Small Outline J-Bend (SOJ)
- 300 MIL Small Outline Gullwing (SOG)

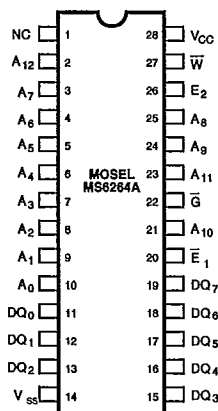
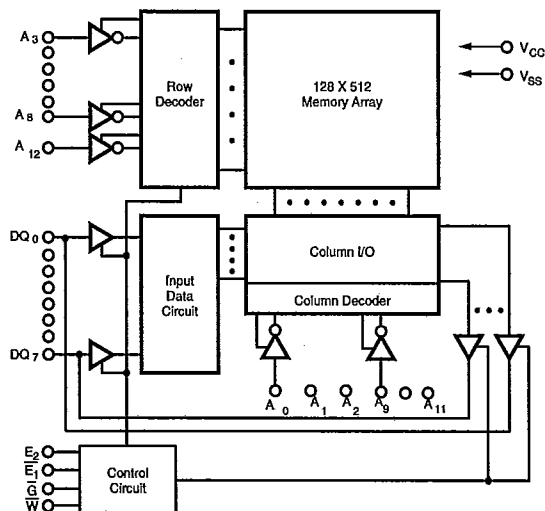
PIN CONFIGURATIONS**FUNCTIONAL BLOCK DIAGRAM**

MS6264A

MOSEL-VITELIC

T-46-23-12

PIN DESCRIPTIONS**A₀ - A₁₂ Address Inputs**

These 13 address inputs select one of the 8192 x 8-bit words in the RAM.

 \bar{E}_1 Chip Enable 1 Input**E₂ Chip Enable 2 Input**

\bar{E}_1 is active LOW and E₂ is active HIGH. Both chip enables must be active to read from or write to the device. If either chip enable is not active, the device is deselected and is in a standby power mode. The DQ pins will be in the high-impedance state when deselected.

 \bar{G} Output Enable Input

The output enable input is active LOW. If the output enable is active while the chip is selected and the write enable is inactive, data will be present on the DQ pins. The DQ pins will be in the high impedance state when \bar{G} is inactive.

 \bar{W} Write Enable Input

The write enable input is active LOW and controls read and write operations. With the chip enabled, when \bar{W} is HIGH and \bar{G} is LOW, output data will be present at the DQ pins; when \bar{W} is LOW, the data present on the DQ pins will be written into the selected memory location.

DQ₀ - DQ₇ Data Input/Output Ports

These 8 bidirectional ports are used to read data from or write data into the RAM.

V_{CC} Power Supply**V_{SS} Ground****TRUTH TABLE**

MODE	\bar{W}	\bar{E}_1	E ₂	\bar{G}	I/O OPERATION	V _{CC} CURRENT
Not Selected	X	H	X	X	High Z	I _{CCSB} , I _{CCSB1}
(Power Down)	X	X	L	X	High Z	I _{CCSB} , I _{CCSB1}
Output Disabled	H	L	H	H	High Z	I _{CC}
Read	H	L	H	L	D _{OUT}	I _{CC}
Write	L	L	H	X	D _{IN}	I _{CC}

ABSOLUTE MAXIMUM RATINGS (1)

SYMBOL	PARAMETER	RATING	UNITS
V _{CC}	Supply Voltage	-0.3 to 7	V
V _{IN}	Input Voltage	-0.3 to 7	
V _{DQ}	Input/Output Voltage Applied	-0.3 to 6	
T _{BIAS}	Temperature Under Bias	Plastic -10 to +125	°C
T _{STG}	Storage Temperature	Plastic -40 to +150	°C
P _D	Power Dissipation	1.0	W
I _{OUT}	DC Output Current	50	mA

1. Stresses greater than those listed under ABSOLUTE MAXIMUM RATINGS may cause permanent damage to the device. This is a stress rating only and functional operation of the device at these or any other conditions above those indicated in the operational sections of this specification is not implied. Exposure to absolute maximum rating conditions for extended periods may affect reliability, and degrade performance characteristics.

OPERATING RANGE

RANGE	AMBIENT TEMPERATURE	V _{CC}
Commercial	0°C to +70°C	5V ± 10%

DC ELECTRICAL CHARACTERISTICS (over the commercial operating range)

T-46-23-12

2

PARAMETER NAME	PARAMETER	TEST CONDITIONS	MS6264A		UNITS	
			MIN.	TYP.(1) MAX.		
V _{IL}	Guaranteed Input Low Voltage ⁽²⁾		-0.5	- 0.8	V	
V _{IH}	Guaranteed Input High Voltage ⁽²⁾		2.2	- 6.0	V	
I _{IL}	Input Leakage Current	V _{CC} = Max, V _{IN} = 0V to V _{CC}	-	- 2	μA	
I _{OL}	Output Leakage Current	V _{CC} = Max, $\bar{E}_1 = V_{IH}$, or $\bar{E}_2 = V_{IL}$, or $\bar{G} = V_{IH}$, V _{IN} = 0V to V _{CC}	-	- 2	μA	
V _{OL}	Output Low Voltage	V _{CC} = Min, I _{OL} = 8mA	-	- 0.4	V	
V _{OH}	Output High Voltage	V _{CC} = Min, I _{OH} = -4mA	2.4	- -	V	
I _{CC}	Operating Power Supply Current	V _{CC} = Max, $\bar{E}_1 = V_{IL}$, $\bar{E}_2 = V_{IH}$, I _{DO} = 0mA, F = F _{max} ⁽³⁾	-	- 150	mA	
I _{CCSB}	Standby Power Supply Current	V _{CC} = Max, $\bar{E}_1 = V_{IH}$, or $\bar{E}_2 = V_{IL}$, I _{DO} = 0mA	-	- 30	mA	
I _{CCSB1}	Power Down Power Supply Current	V _{CC} = Max, $\bar{E}_1 \geq V_{CC} - 0.2V$, $\bar{E}_2 \leq 0.2V$	L ⁽⁴⁾	-	100	μA
		V _{IN} ≥ V _{CC} - 0.2V or V _{IN} ≤ 0.2V	S	-	20	mA

1. Typical characteristics are at V_{CC} = 5V, T_A = 25°C.
2. These are absolute values with respect to device ground and all overshoots due to system or tester noise are included.
3. F_{max} = 1/t_{RC}.
4. Low power version only.

CAPACITANCE⁽¹⁾ (T_A = 25°C, f = 1.0MHz)

SYMBOL	PARAMETER	CONDITIONS	MAX.	UNIT
C _{IN}	Input Capacitance	V _{IN} = 0V	8	pF
C _{VO}	Input/Output Capacitance	V _{IO} = 0V	10	pF

1. This parameter is guaranteed and not tested.

DATA RETENTION CHARACTERISTICS (over the commercial operating range)

SYMBOL	PARAMETER	TEST CONDITIONS	MIN.	TYP.(1) MAX.	UNITS
V _{DR}	V _{CC} for Data Retention	$\bar{E}_1 \geq V_{CC} - 0.2V$, $\bar{E}_2 \leq 0.2V$, V _{IN} ≥ V _{CC} - 0.2V or V _{IN} ≤ 0.2V	2.0	- -	V
I _{CCDR}	Data Retention Current	$\bar{E}_1 \geq V_{CC} - 0.2V$, $\bar{E}_2 \leq 0.2V$, V _{IN} ≥ V _{CC} - 0.2V or V _{IN} ≤ 0.2V	-	2 50 ⁽³⁾	μA
I _{IL}	Input Leakage Current		-	- 2	μA
t _{CDR}	Chip Deselect to Data Retention Time	See Retention Waveform	0	- -	ns
t _R	Operation Recovery Time		t _{RC} ⁽²⁾	-	-

1. V_{CC} = 2V, T_A = +25°C
2. t_{RC} = Read Cycle Time
3. For low power version only

LOW V_{CC} DATA RETENTION WAVEFORM (\bar{E}_1 Controlled)

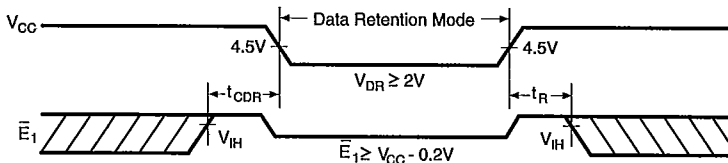

MS6264A

MOSEL-VITELIC

T-46-23-12

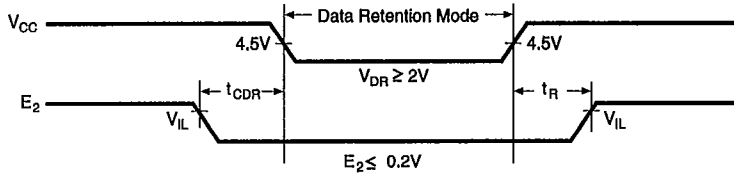

AC TEST CONDITIONS

Input Pulse Levels	0V to 3.0V
Input Rise and Fall Times	3ns
Timing Reference Level	1.5V

AC TEST LOADS AND WAVEFORMS

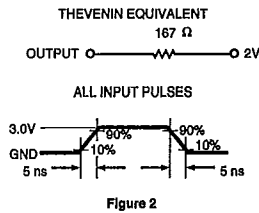
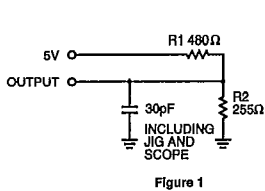

KEY TO SWITCHING WAVEFORMS

WAVEFORM	INPUTS	OUTPUTS
	MUST BE STEADY	WILL BE STEADY
	MAY CHANGE FROM H TO L	WILL BE CHANGING FROM H TO L
	MAY CHANGE FROM L TO H	WILL BE CHANGING FROM L TO H
	DON'T CARE; ANY CHANGE PERMITTED	CHANGING; STATE UNKNOWN
	DOES NOT APPLY	CENTER LINE IS HIGH IMPEDANCE 'OFF' STATE

AC ELECTRICAL CHARACTERISTICS (over the commercial operating range)

READ CYCLE

JEDEC PARAMETER NAME	PARAMETER NAME	PARAMETER	MS6264A-20		MS6264A-25		MS6264A-30		UNIT
			MIN.	MAX.	MIN.	MAX.	MIN.	MAX.	
t _{AVAX}	t _{RC}	Read Cycle Time	20	-	25	-	30	-	ns
t _{AVQV}	t _{AA}	Address Access Time	-	20	-	25	-	30	ns
t _{ELQV}	t _{ACS1}	Chip Enable Access Time	-	20	-	25	-	30	ns
t _{ELQV}	t _{ACS2}	Chip Enable Access Time	-	22	-	27	-	32	ns
t _{GLQX}	t _{OE}	Output Enable to Output Valid	-	10	-	15	-	15	ns
t _{EHQZ}	t _{CLZ}	Chip Enable to Output Low Z	5	-	5	-	5	-	ns
t _{GLQX}	t _{OLZ}	Output Enable to Output in Low Z	0	-	0	-	0	-	ns
t _{EHQZ}	t _{CHZ}	Chip Disable to Output in High Z	-	10	-	15	-	15	ns
t _{GHQZ}	t _{OHZ}	Output Disable to Output in High Z	-	10	-	15	-	15	ns
t _{AXQX}	t _{OH}	Output Hold from Address Change	5	-	5	-	5	-	ns

SWITCHING WAVEFORMS (READ CYCLE)

T-46-23-12

READ CYCLE 1^(1,2,4)

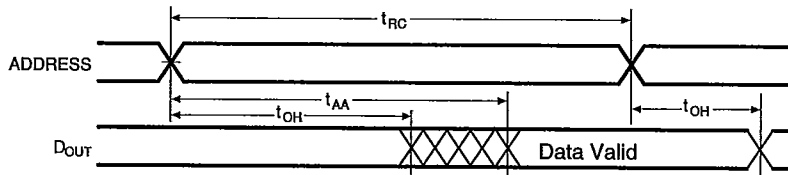

READ CYCLE 2⁽¹⁾

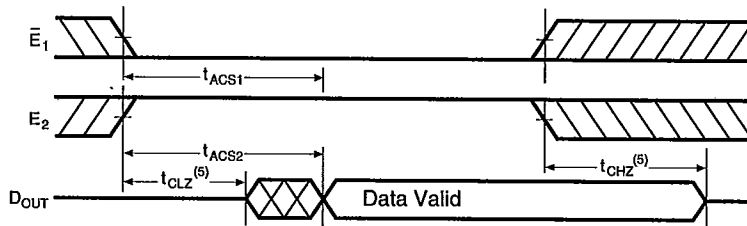

READ CYCLE 3^(1,3,4)

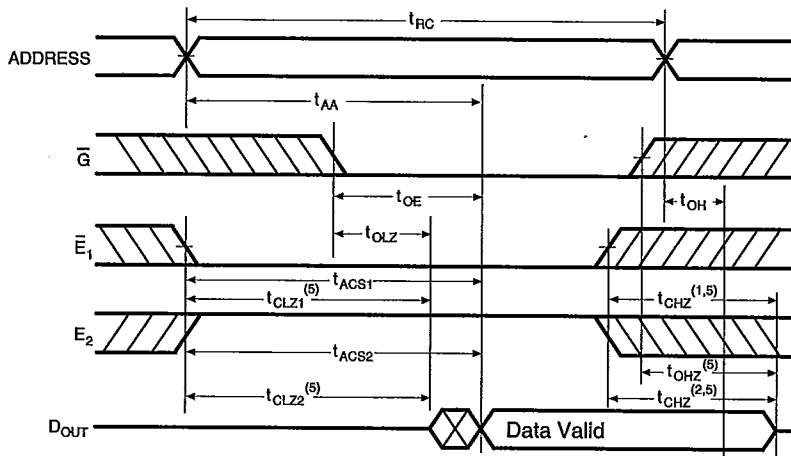

Notes:

1. \bar{W} is high during all read cycles.
2. Device is continuously selected $\bar{E}_1 = V_{IL}$ and $E_2 = V_{IH}$.
3. Address valid prior to or coincident with \bar{E}_1 transition low and /or E_2 transition high.
4. $\bar{G} = V_{IL}$.
5. Transition is measured +500mV from steady state with $C_L = 5pF$. This parameter is guaranteed and not 100% tested.

MS6264A

MOSEL-VITELIC

T-46-23-12

AC ELECTRICAL CHARACTERISTICS (over the commercial operating range)

WRITE CYCLE

JEDEC PARAMETER NAME	PARAMETER NAME	PARAMETER	MS6264A-20		MS6264A-25		MS6264A-30		UNIT
			MIN.	MAX.	MIN.	MAX.	MIN.	MAX.	
t_{AVAX}	t_{WC}	Write Cycle Time	20	-	25	-	30	-	ns
t_{ELWH}	t_{CW}	Chip Enable to End of Write	15	-	20	-	25	-	ns
t_{AVWL}	t_{AS}	Address Set up Time	0	-	0	-	0	-	ns
t_{AVWH}	t_{AW}	Address Valid to End of Write	15	-	20	-	25	-	ns
t_{WLWH}	t_{WP}	Write Pulse Width	15	-	20	-	25	-	ns
t_{WHAX}	t_{WR}	Write Recovery Time	0	-	0	-	0	-	ns
t_{WLQZ}	t_{WHZ}	Write to Output in High Z	0	15	0	20	0	25	ns
t_{DVWH}	t_{DW}	Data to Write Time Overlap	15	-	20	-	25	-	ns
t_{WHDX}	t_{DH}	Data Hold from Write Time	0	-	0	-	0	-	ns
t_{GHQZ}	t_{OHZ}	Output Disable to Output in High Z	0	10	0	15	0	15	ns
t_{WHQX}	t_{OW}	Output Active from End of Write	5	-	5	-	5	-	ns

SWITCHING WAVEFORMS (WRITE CYCLE)

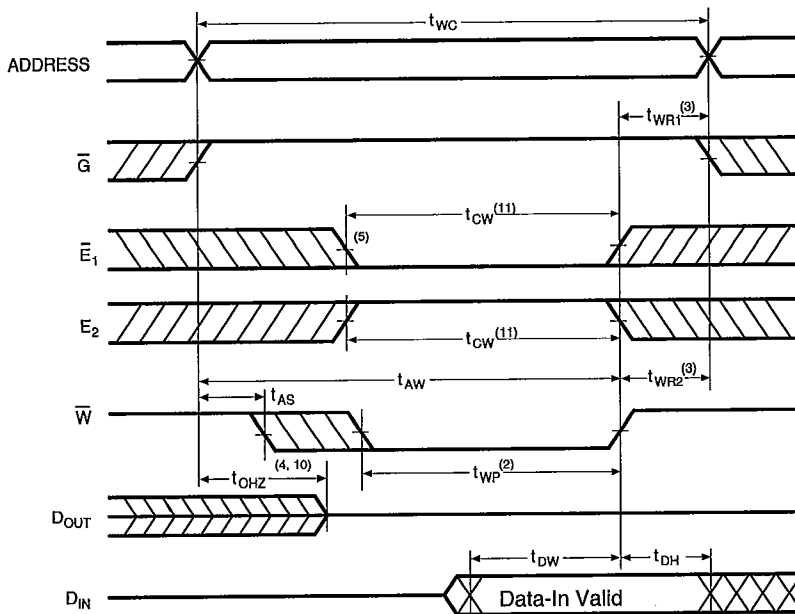
WRITE CYCLE 1⁽¹⁾

T-46-23-12

SWITCHING WAVEFORMS (WRITE CYCLE)

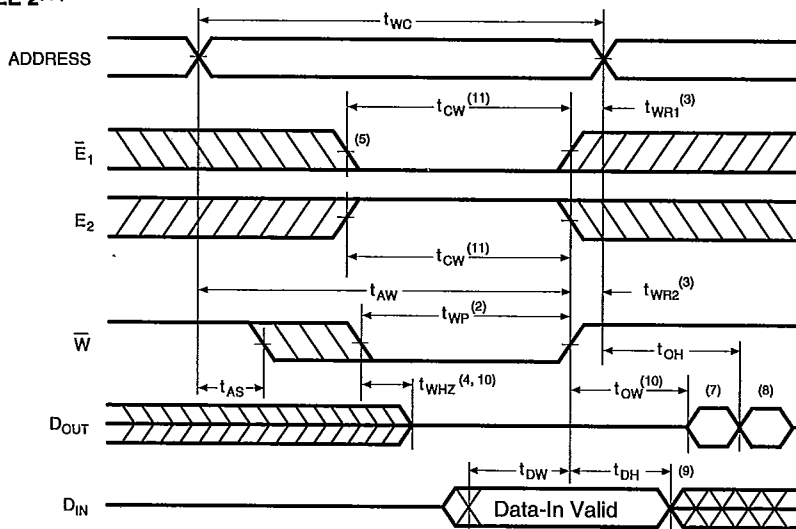
WRITE CYCLE 2^(1,6)

Notes:

- \bar{W} must be high during address transitions.
- The internal write time of the memory is defined by the overlap of \bar{E}_1 and E_2 active and \bar{W} low. All signals must be active to initiate a write and any one signal can terminate a write by going inactive. The data input setup and hold timing should be referenced to the second transition edge of the signal that terminates the write.
- t_{WR} is measured from the earlier of \bar{E}_1 or \bar{W} going high or E_2 going low at the end of write cycle.
- During this period, DQ pins are in the output state so that the input signals of opposite phase to the outputs must not be applied.
- If the \bar{E}_1 low transition or the E_2 high transition occurs simultaneously with the \bar{W} low transitions or after the \bar{W} transition, outputs remain in a high impedance state.
- \bar{G} is continuously low ($\bar{G} = V_{IL}$).
- D_{OUT} is the same phase of write data of this write cycle.
- D_{OUT} is the read data of next address.
- If \bar{E}_1 is low and E_2 is high during this period, DQ pins are in the output state. Then the data input signals of opposite phase to the output must not be applied to them.
- Transition is measured $\pm 500\text{mV}$ from steady state with $C_L = 5\text{pF}$. This parameter is guaranteed but not 100% tested.
- t_{CW} is measured from the later of \bar{E}_1 going low or E_2 going high to the end of write.

MS6264A

MOSEL-VITELIC

T-46-23-12

ORDERING INFORMATION

SPEED (ns)	ORDERING PART NUMBER	PACKAGE REFERENCE NO.	TEMPERATURE RANGE
20	MS6264A-20PC	P28-1	0°C to +70°C
20	MS6264A-20NC	P28-2	0°C to +70°C
20	MS6264A-20RC	R28-1	0°C to +70°C
20	MS6264A-20SC	S28-6	0°C to +70°C
25	MS6264A-25PC	P28-1	0°C to +70°C
25	MS6264A-25NC	P28-2	0°C to +70°C
25	MS6264A-25RC	R28-1	0°C to +70°C
25	MS6264A-25SC	S28-6	0°C to +70°C
30	MS6264A-30PC	P28-1	0°C to +70°C
30	MS6264A-30NC	P28-2	0°C to +70°C
30	MS6264A-30RC	R28-1	0°C to +70°C
30	MS6264A-30SC	S28-6	0°C to +70°C

To order low power device, add "L" after part number and before speed. For example, MS6264AL-20PC.