

S15WB □

800V 15A

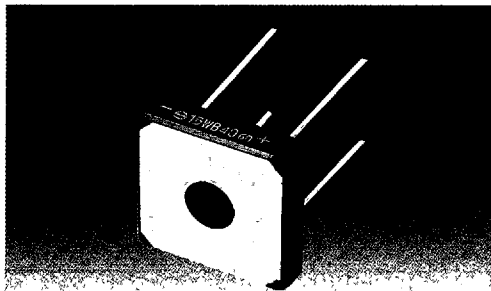

■ 外形寸法図 OUTLINE DIMENSIONS

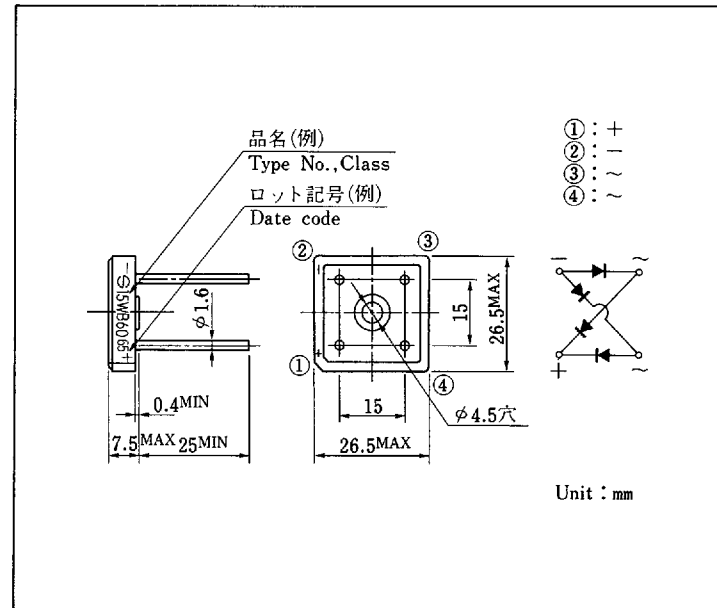

■ 定格表 RATINGS

絶対最大定格 Absolute Maximum Ratings

項目 Item	記号 Symbol	条件 Conditions	品名 Type No.					単位 Unit
			S15WB10	S15WB20	S15WB40	S15WB60	S15WB80	
保存温度 Storage Temperature	Tstg		-40~150					°C
接合部温度 Operating Junction Temperature	Tj		150					°C
せん頭逆電圧 Maximum Reverse Voltage	VRM		100	200	400	600	800	V
出力電流 Average Rectified Forward Current	Io	50Hz 正弦波, 抵抗負荷 50Hz sine wave, R-load	フィン付き With heatsink					A
			フィンなし Without heatsink					
せん頭サージ順電流 Peak Surge Forward Current	IFSM	50Hz 正弦波, 非繰り返し1サイクルせん頭値, Tj=25°C 50Hz sine wave, Non-repetitive 1 cycle peak value, Tj=25°C	15					A
電流2乗時間積 Current Squared Time	I ² t	1ms ≤ t < 10ms Tc=25°C	4					A ² s
絶縁耐圧 Dielectric Strength	Vdis	一括端子・ケース間, AC 1 分間印加 Terminals to case, AC 1 minute	200					kV
締め付けトルク Mounting Torque	TOR	(推奨値: 10kg·cm) (Recommended torque: 10kg·cm)	2					kg·cm

電氣的・熱的特性 Electrical Characteristics (Tc=25°C)

順電圧 Forward Voltage	VF	IF=7.5A, パルス測定, 1素子当りの規格値 Pulse measurement, Rating of per diode	MAX	1.05	V
逆電流 Reverse Current	IR	VR=VRM, パルス測定, 1素子当りの規格値 Pulse measurement, Rating of per diode	MAX	10	μA
熱抵抗 Thermal Resistance	θjc	接合部・ケース間 Between junction and case	MAX	2.5	°C/W
	θjl	接合部・リード間 Between junction and lead	MAX	2	
	θja	接合部・周囲間 Between junction and ambient	MAX	19	

■ 特性図 CHARACTERISTIC DIAGRAMS

T-23-07

