

1 - Cathode
2 - Anode
Back of Case - Cathode

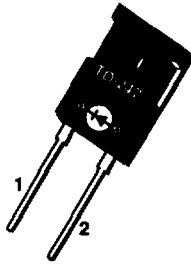

APT60D100B 1000V 60A
APT60D90B 900V 60A
APT60D80B 800V 60A

ULTRAFAST SOFT RECOVERY RECTIFIER DIODE

PRODUCT APPLICATIONS	PRODUCT FEATURES	PRODUCT BENEFITS
<ul style="list-style-type: none"> • Anti-Parallel Diode -Switchmode Power Supply -Inverters • Free Wheeling Diode -Motor Controllers -Converters • Snubber Diode • Uninterruptible Power Supply (UPS) • Induction Heating • High Speed Rectifiers 	<ul style="list-style-type: none"> • Ultrafast Recovery Times • Soft Recovery Characteristics • Popular TO-247 Package • Low Forward Voltage • High Blocking Voltage • Low Leakage Current 	<ul style="list-style-type: none"> • Low Losses • Low Noise Switching • Cooler Operation • Higher Reliability Systems • Increased System Power Density

MAXIMUM RATINGS

All Ratings: $T_C = 25^\circ\text{C}$ unless otherwise specified.

Symbol	Characteristic / Test Conditions	APT60D100B-90B-80B	UNIT
V_R	Maximum D.C. Reverse Voltage	1000-900-800	Volts
V_{RRM}	Maximum Peak Repetitive Reverse Voltage		
V_{RWM}	Maximum Working Peak Reverse Voltage		
$I_F(AV)$	Maximum Average Forward Current ($T_C = 60^\circ\text{C}$, Duty Cycle = 0.5)	60	Amps
$I_F(RMS)$	RMS Forward Current	100	
I_{FSM}	Non-Repetitive Forward Surge Current ($T_J = 45^\circ\text{C}$, 8.3ms)	540	$^\circ\text{C}$
T_J, T_{STG}	Operating and Storage Temperature Range	-55 to 150	
T_L	Lead Temperature: 0.063" from Case for 10 Sec.	300	

STATIC ELECTRICAL CHARACTERISTICS

Symbol	Characteristic / Test Conditions	MIN	TYP	MAX	UNIT
V_F	Maximum Forward Voltage			2.3	Volts
				$I_F = 60\text{A}$	
				$I_F = 120\text{A}$	
I_{RM}	Maximum Reverse Leakage Current			1.8	μA
				$I_F = 60\text{A}, T_J = 150^\circ\text{C}$	
C_T	Junction Capacitance, $V_R = 200\text{V}$		65		pF
L_S	Series Inductance (Lead to Lead 5mm from Base)		10		nH

405 S.W. COLUMBIA STREET
BEND, OREGON 97702-1035
U.S.A.

PHONE . . . (503) 382-8028

FAX (503) 388-0364

DYNAMIC CHARACTERISTICS

APT60D100B-90B-80B

Symbol	Characteristic	MIN	TYP	MAX	UNIT
t_{rr1}	Reverse Recovery Time, $I_F = 1.0A$, $di_F/dt = -15A/\mu S$, $V_R = 30V$, $T_J = 25^\circ C$		70	85	nS
t_{rr2}	Reverse Recovery Time	$T_J = 25^\circ C$	70	85	
t_{rr3}	$I_F = 60A$, $di_F/dt = -480A/\mu S$, $V_R = 540V$	$T_J = 100^\circ C$	130	200	
t_{fr1}	Forward Recovery Time	$T_J = 25^\circ C$	165		
t_{fr2}	$I_F = 60A$, $di_F/dt = 480A/\mu S$, $V_R = 540V$	$T_J = 100^\circ C$	165		
I_{RRM1}	Reverse Recovery Current	$T_J = 25^\circ C$	14	26	Amps
I_{RRM2}	$I_F = 60A$, $di_F/dt = -480A/\mu S$, $V_R = 540V$	$T_J = 100^\circ C$	26	36	
Q_{rr1}	Recovery Charge	$T_J = 25^\circ C$	500	1105	nC
Q_{rr2}	$I_F = 60A$, $di_F/dt = -480A/\mu S$, $V_R = 540V$	$T_J = 100^\circ C$	1700	3600	
V_{fr1}	Forward Recovery Voltage	$T_J = 25^\circ C$	10		Volts
V_{fr2}	$I_F = 60A$, $di_F/dt = 480A/\mu S$, $V_R = 540V$	$T_J = 100^\circ C$	10		
diM/dt	Rate of Fall of Recovery Current $I_F = 60A$, $di_F/dt = -480A/\mu S$, $V_R = 540V$ (See Figure 10)	$T_J = 25^\circ C$	900		A/ μS
		$T_J = 100^\circ C$	600		

THERMAL AND MECHANICAL CHARACTERISTICS

Symbol	Characteristic / Test Conditions	MIN	TYP	MAX	UNIT
$R_{\theta JC}$	Junction-to-Case Thermal Resistance			0.66	$^\circ C/W$
$R_{\theta JA}$	Junction-to-Ambient Thermal Resistance			40	
W_T	Package Weight		0.22		oz.
			6.1		gm.
Torque	Maximum Mounting Torque (Screw Type = 6-32 or 3mm Machine)			10	lb. in.
				1.1	Nm

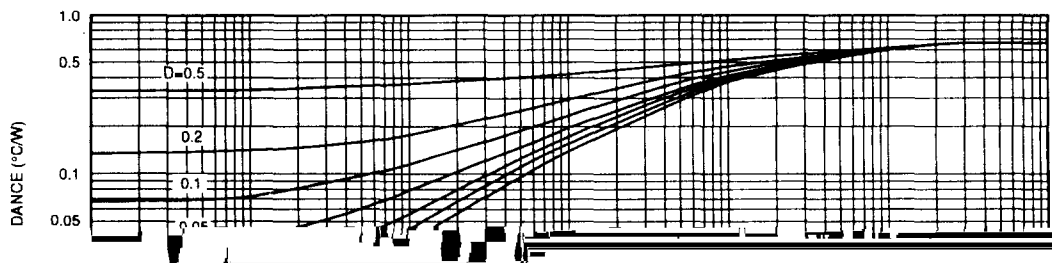

APT60D100B-90B-80B

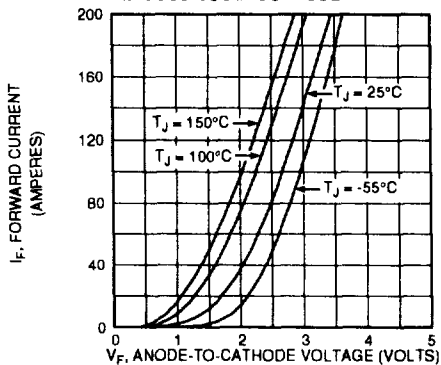

Figure 2, Forward Voltage Drop vs Forward Current

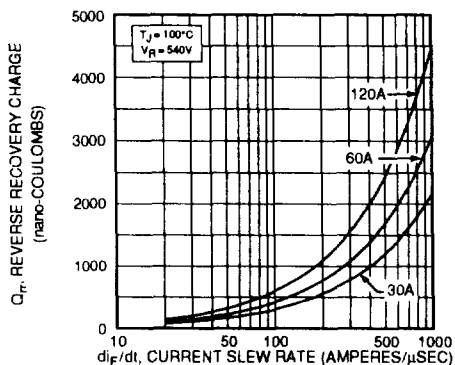

Figure 3, Reverse Recovery Charge vs Current Slew Rate

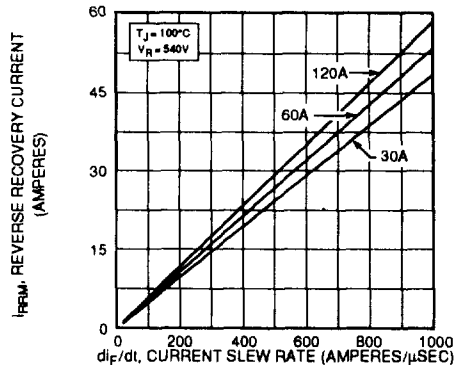

Figure 4, Reverse Recovery Current vs Current Slew Rate

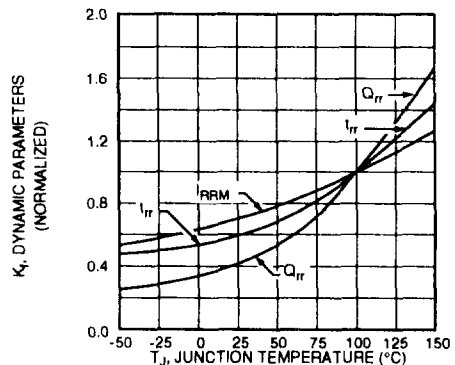

Figure 5, Dynamic Parameters vs Junction Temperature

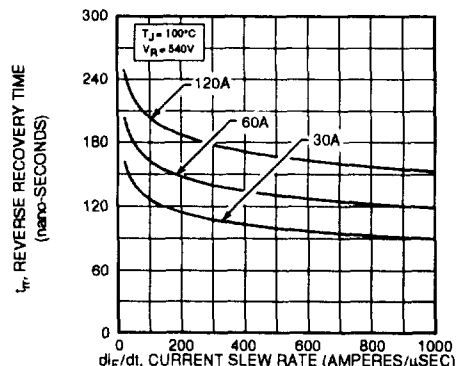

Figure 6, Reverse Recovery Time vs Current Slew Rate

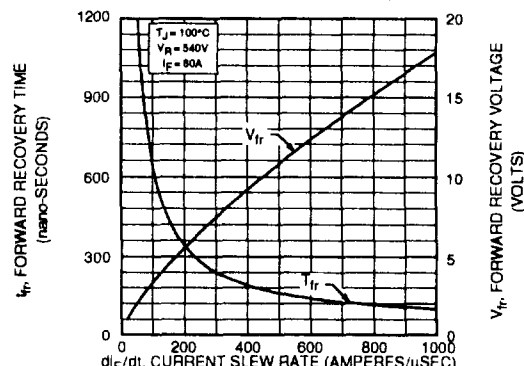

Figure 7, Forward Recovery Voltage/Time vs Current Slew Rate

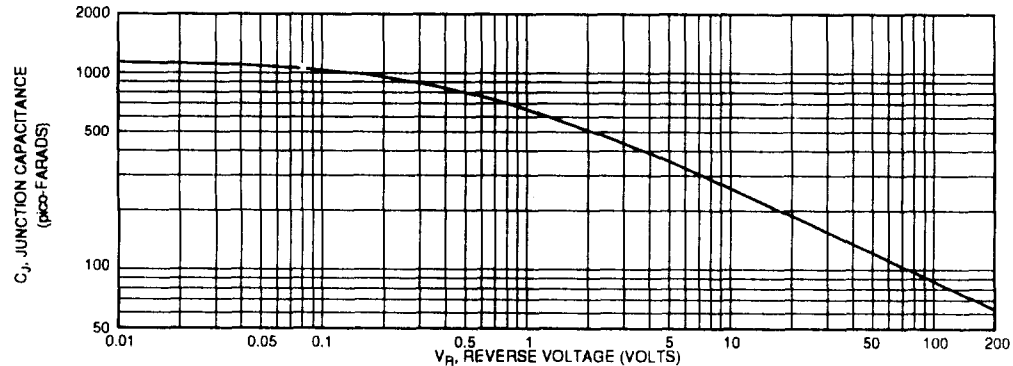

Figure 8, Junction Capacitance vs Reverse Voltage

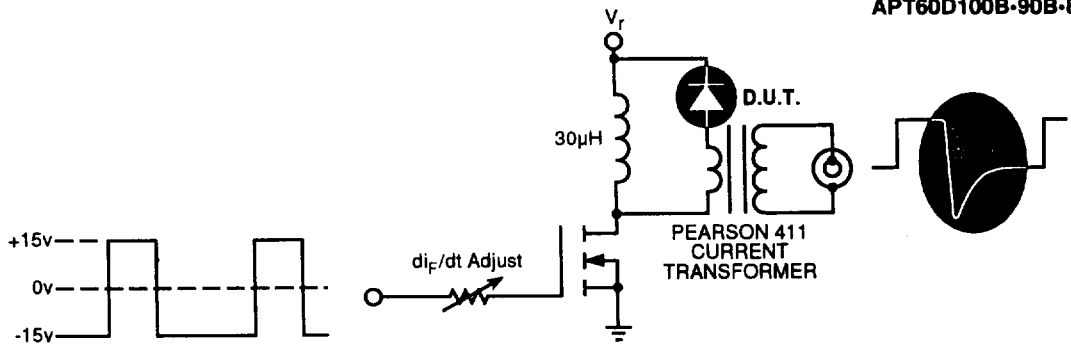

Figure 9, Diode Reverse Recovery Test Circuit and Waveforms

- 1 I_F - Forward Conduction Current
- 2 di_F/dt - Current Slew Rate, Rate of Forward Current Change Through Zero Crossing.
- 3 I_{RRM} - Peak Reverse Recovery Current.
- 4 t_{rr} - Reverse Recovery Time Measured from Point of I_F Current Falling Through Zero to a Tangent Line {6 diM/dt } Extrapolated Through Zero Defined by 0.75 and 0.50 I_{RRM} .
- 5 Q_{rr} - Area Under the Curve Defined by I_{RRM} and t_{rr} .
- 6 diM/dt - Maximum Rate of Current Change During the Trailing Portion of t_{rr} .

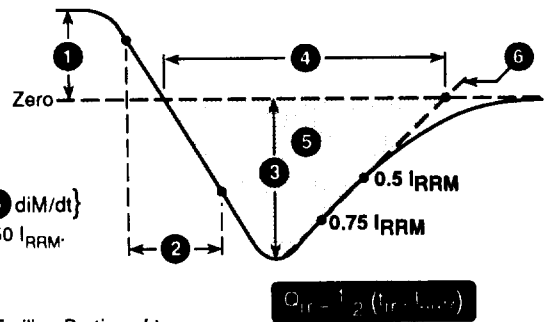
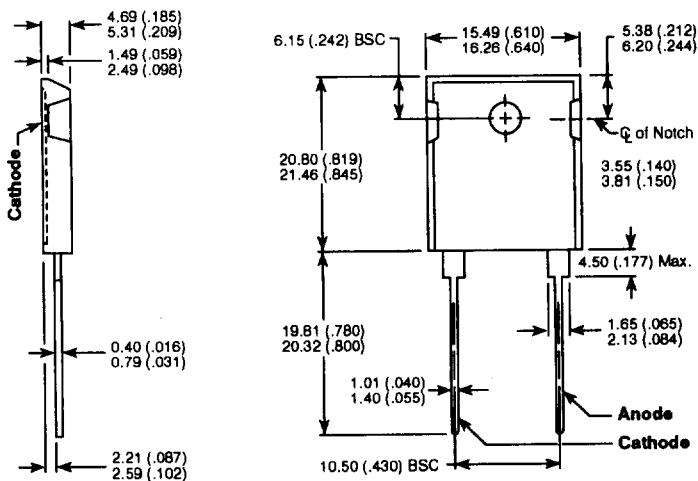

Figure 10, Diode Reverse Recovery Waveform and Definitions

TO-247AD Package Outline



Dimensions in Millimeters and (Inches)