



5SDA 06P38

Old part no. DA 805-600-38

Avalanche Diode

Properties

- § Low forward voltage drop
- § Avalanche reverse characteristics
- § Guaranteed maximum avalanche power dissipation
- § Version with or without lead
- § Both polarity options
- § High operational reliability

Key Parameters

V_{RRM}	=	3 800	V
I_{FAVm}	=	600	A
I_{FSM}	=	7 600	A
V_{TO}	=	1.010	V
r_T	=	0.720	m Ω

Types

	<i>Old part no.</i>	V_{RRM}	<i>version</i>
5SDA 06P3816	DA 805S-600-38	3 800 V	without lead anode on the base
5SDA 06P3216	DA 805S-600-32	3 200 V	
5SDA 06P3826	DA 805S-600R-38	3 800 V	without lead cathode on the base
5SDA 06P3226	DA 805S-600R-32	3 200 V	
5SDA 06P3836	DA 805-600-38	3 800 V	with lead anode on the base
5SDA 06P3236	DA 805-600-32	3 200 V	
5SDA 06P3846	DA 805-600R-38	3 800 V	with lead cathode on the base
5SDA 06P3246	DA 805-600R-32	3 200 V	
Conditions:		$T_j = -40 \div 160$ °C, half sine waveform, $f = 50$ Hz	



ABB s.r.o.

Novodvorska 1768/138a, 142 21 Praha 4, Czech Republic

tel.: +420 261 306 250, <http://www.abb.com/semiconductors>

Mechanical Data

M_m	Mounting torque of screws (each screw)	3.5 ± 0.3	N
F_t	Tensile force of cathode (anode) lead	100	N
m	Weight without lead with lead	460 700	g
D_s	Surface creepage distance	38	mm
D_a	Air strike distance	27	mm

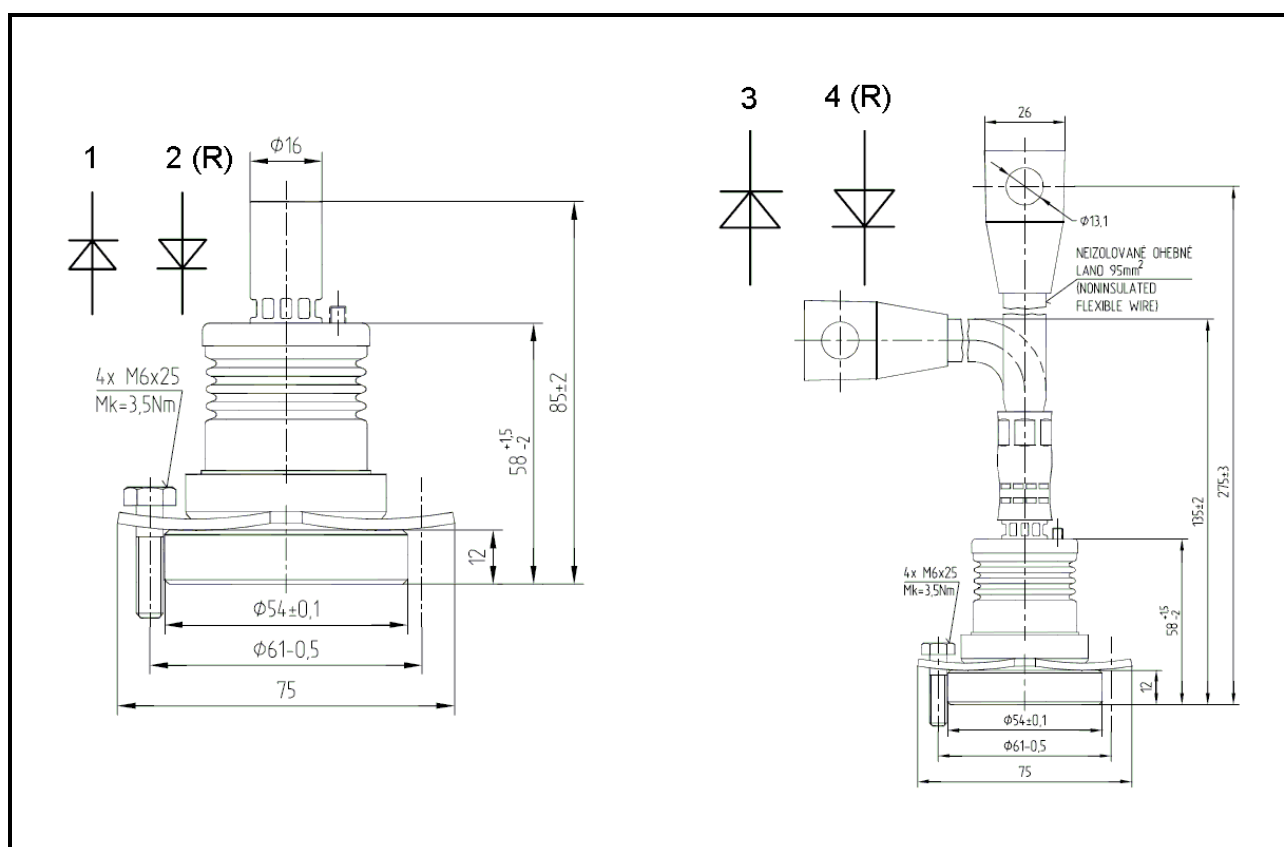

Fig. 1 Case – version without and with lead

Maximum Ratings			Maximum Limits	Unit
V_{RRM}	Repetitive peak reverse voltage $T_j = -40 \div 160 \text{ }^\circ\text{C}$	5SDA 06P38.. 5SDA 06P32..	3 800 3 200	V
V_{RSM}	Non-repetitive peak reverse voltage $T_j = -40 \div 160 \text{ }^\circ\text{C}$	5SDA 06P38.. 5SDA 06P32..	3 800 3 200	V
I_{FAVm}	Average forward current $T_c = 85 \text{ }^\circ\text{C}$		600	A
I_{FRMS}	RMS forward current $T_c = 85 \text{ }^\circ\text{C}$		942	A
I_{RRM}	Repetitive reverse current $V_R = V_{RRM}$		50	mA
I_{FSM}	Non repetitive peak surge current $V_R = 0 \text{ V, half sine pulse}$	$t_p = 8.3 \text{ ms}$	8 100	A
		$t_p = 10 \text{ ms}$	7 600	A
I^2t	Limiting load integral $V_R = 0 \text{ V, half sine pulse}$	$t_p = 8.3 \text{ ms}$	273 000	A ² s
		$t_p = 10 \text{ ms}$	289 000	A ² s
P_{RSM}	Maximum avalanche power dissipation $t_p = 20 \text{ } \mu\text{s, single pulse}$	$T_j = 45 \text{ }^\circ\text{C}$	70	kW
		$T_j = 160 \text{ }^\circ\text{C}$	50	kW
$T_{jmin} - T_{jmax}$	Operating temperature range		-40 \div 160	$^\circ\text{C}$
T_{STG}	Storage temperature range		-40 \div 160	$^\circ\text{C}$

Unless otherwise specified $T_j = 160 \text{ }^\circ\text{C}$

Characteristics		Value			Unit
		<i>min</i>	<i>typ</i>	<i>max</i>	
V_{T0}	Threshold voltage			1.010	V
r_T	Forward slope resistance $I_{F1} = 800 \text{ A, } I_{F2} = 2\,400 \text{ A}$			0.720	mW
V_{FM}	Maximum forward voltage $I_{FM} = 1\,800 \text{ A, } T_j = 25 \text{ }^\circ\text{C}$			2.000	V
R_{thjc}	Thermal resistance junction to case			60	K/kW

Unless otherwise specified $T_j = 160 \text{ }^\circ\text{C}$

Notes: