

Signetics

Document No.	853-1120
ECN No.	
Date of issue	June 12, 1990
Status	Product Specification
FAST Products	

FAST 74F8960, 74F8961 Futurebus Transceivers

74F8960-Octal Latched Bidirectional Futurebus Transceiver, INV (OC)
74F8961-Octal Latched Bidirectional Futurebus Transceiver, NINV (OC)

FEATURES

- Octal Latched Transceiver
- Drives heavily loaded backplanes with equivalent load impedances down to 10 ohms
- High drive (100mA) open collector drivers on B-port
- Reduced voltage swing (1 volt) produces less noise and reduces power consumption
- High speed operation enhances performance of backplane buses and facilitates incident wave switching
- Compatible with IEEE 896 Futurebus Standard
- Built-in precision band-gap reference provides accurate receiver thresholds and improved noise immunity
- Controlled output ramp and multiple GND pins minimize ground bounce
- Glitch-free power up / power down operation

DESCRIPTION

The 74F8960 and 74F8961 are octal bidirectional latched transceivers and are intended to provide the electrical interface to a high performance wired-OR bus. The B port inverting drivers are low-capacitance open collector with controlled ramp and are designed to sink 100 mA from 2 volts. The B port receivers have a 100 mV threshold region and a 4 ns glitch filter.

The B port interfaces to 'Backplane Transceiver Logic' (BTL). BTL features a re-

TYPE	TYPICAL PROPAGATION DELAY	TYPICAL SUPPLY CURRENT (TOTAL)
74F8960	6.5ns	80mA
74F8961	6.5ns	80mA

ORDERING INFORMATION

PACKAGES	COMMERCIAL RANGE $V_{CC} = 5V \pm 10\%$; $T_A = 0^\circ C$ to $+70^\circ C$
28-Pin Plastic DIP (600 mil) ¹	N74F8960N, N74F8961N
28-Pin PLCC ¹	N74F8960A, N74F8961A

NOTE:

1. Thermal mounting techniques are recommended. See SMD Process Applications (page 17) for a discussion of thermal consideration for surface mounted devices.

INPUT AND OUTPUT LOADING AND FAN-OUT TABLE

PINS	DESCRIPTION	74F(U.L.) HIGH/LOW	LOAD VALUE HIGH/LOW
A ₀ - A ₇	PNP latched inputs	3.5/0.0117	70μA/70μA
B ₀ - B ₇	Data inputs with threshold circuitry	5.0/0.167	100μA/100μA
OEA	A Output Enable input (active High)	1.0/0.033	20μA/20μA
$\overline{OEB}_0, \overline{OEB}_1$	B Output Enable inputs (active Low)	1.0/0.033	20μA/20μA
\overline{LE}	Latch Enable input (active Low)	1.0/0.033	20μA/20μA
A ₀ - A ₇	3-State outputs	150/40	3mA/24mA
B ₀ - B ₇	Open Collector outputs	OC*/166.7	OC*/100mA

NOTES:

One (1.0) FAST Unit Load is defined as: 20μA in the High state and 0.6mA in the Low state.

* OC = Open Collector

duced (1V) voltage swing for lower power consumption and a series diode on the drivers to reduce capacitive loading (<5 pF).

Incident wave switching is employed, therefore BTL propagation delays are short. Although the voltage swing is much less for BTL, so is its receiver threshold region, therefore noise margins are excellent.

BTL offers low power consumption, low

ground bounce, EMI and crosstalk, low capacitive loading, superior noise margin and low propagation delays. This results in a high bandwidth, reliable backplane. The 74F8960 and 74F8961 A ports have TTL 3-State drivers and TTL receivers with a latch function. A separate High level control input (V_x) is provided to limit the A port output level to a given voltage level (such as 3.3V). For 5.0V systems, V_x is simply tied to V_{CC} .

74F8961 is the non-inverting version of 74F8960.

Futurebus Transceivers

FAST 74F8960, 74F8961

PIN CONFIGURATION DIP

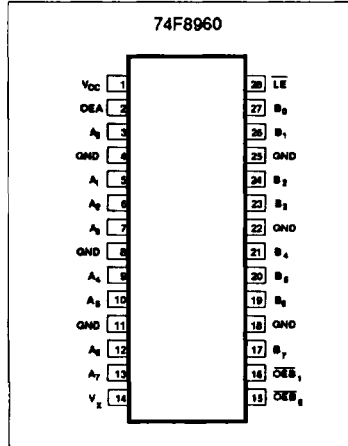

PIN CONFIGURATION PLCC

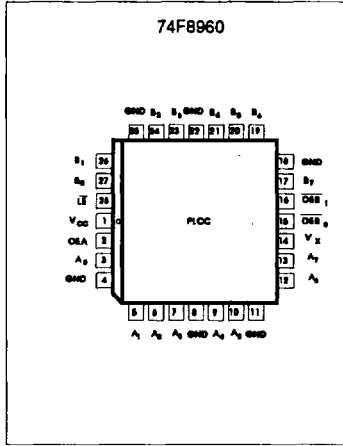

LOGIC SYMBOL

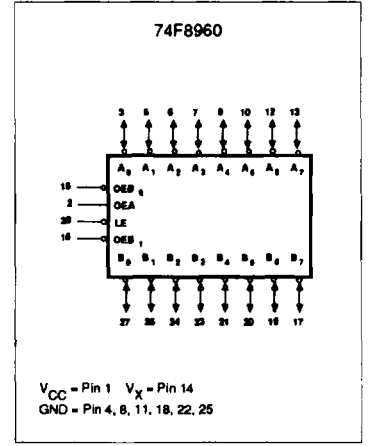

PIN CONFIGURATION

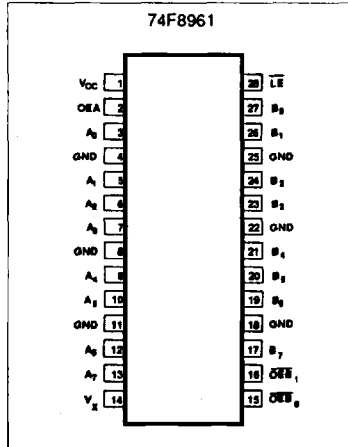

PIN CONFIGURATION PLCC

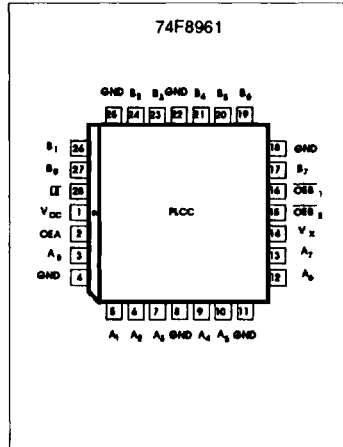

LOGIC SYMBOL

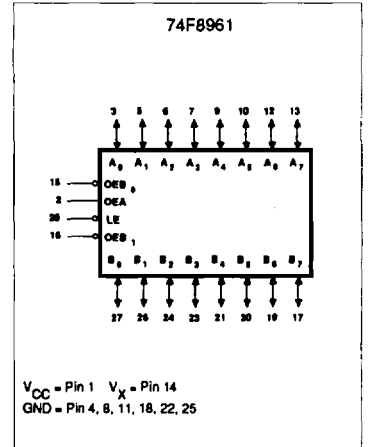

PIN DESCRIPTION

SYMBOL	PINS	TYPE	NAME AND FUNCTION
$A_0 - A_7$	3, 5, 6, 7, 9, 10, 12, 13	I/O	PNP latched input / 3-state output (with V_X control option)
$B_0 - B_7$	27, 26, 24, 23, 21, 20, 19, 17	I/O	Data input with special threshold circuitry to reject noise / Open Collector output, High current drive
\overline{OE}_0	15	Input	Enables the B outputs when both pins are Low
\overline{OE}_1	16	Input	
OEA	2	Input	Enables the A outputs when High
\overline{LE}	28	Input	Latched when High (a special delay feature is built in for proper enabling times)
V_X	14	Input	Clamping voltage keeping V_{OH} from rising above V_X ($V_X = V_{CC}$ for normal use)

Futurebus Transceivers

FAST 74F8960, 74F8961

LOGIC DIAGRAM 74F8960

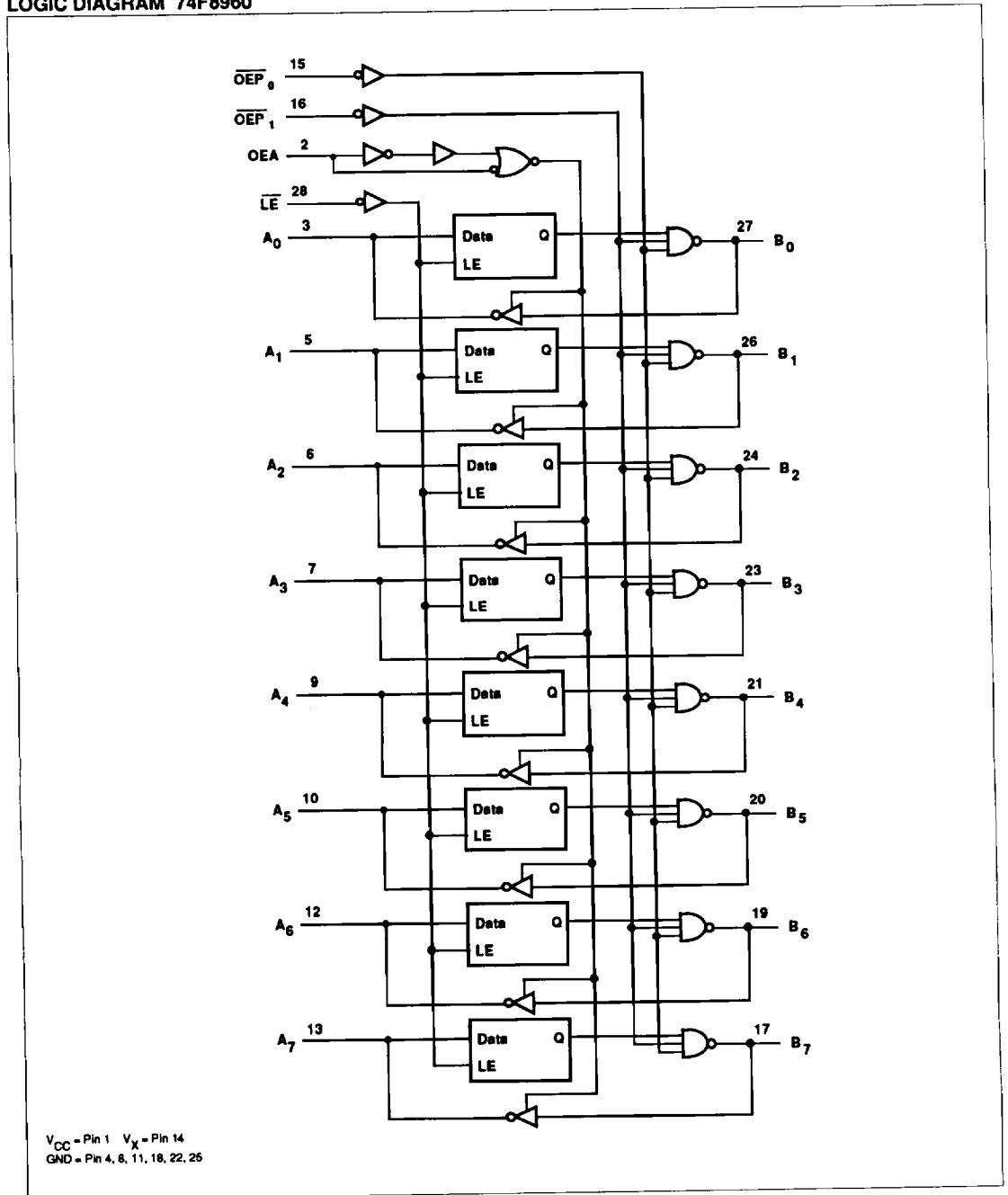

Futurebus Transceivers

FAST 74F8960, 74F8961

LOGIC DIAGRAM 74F8961

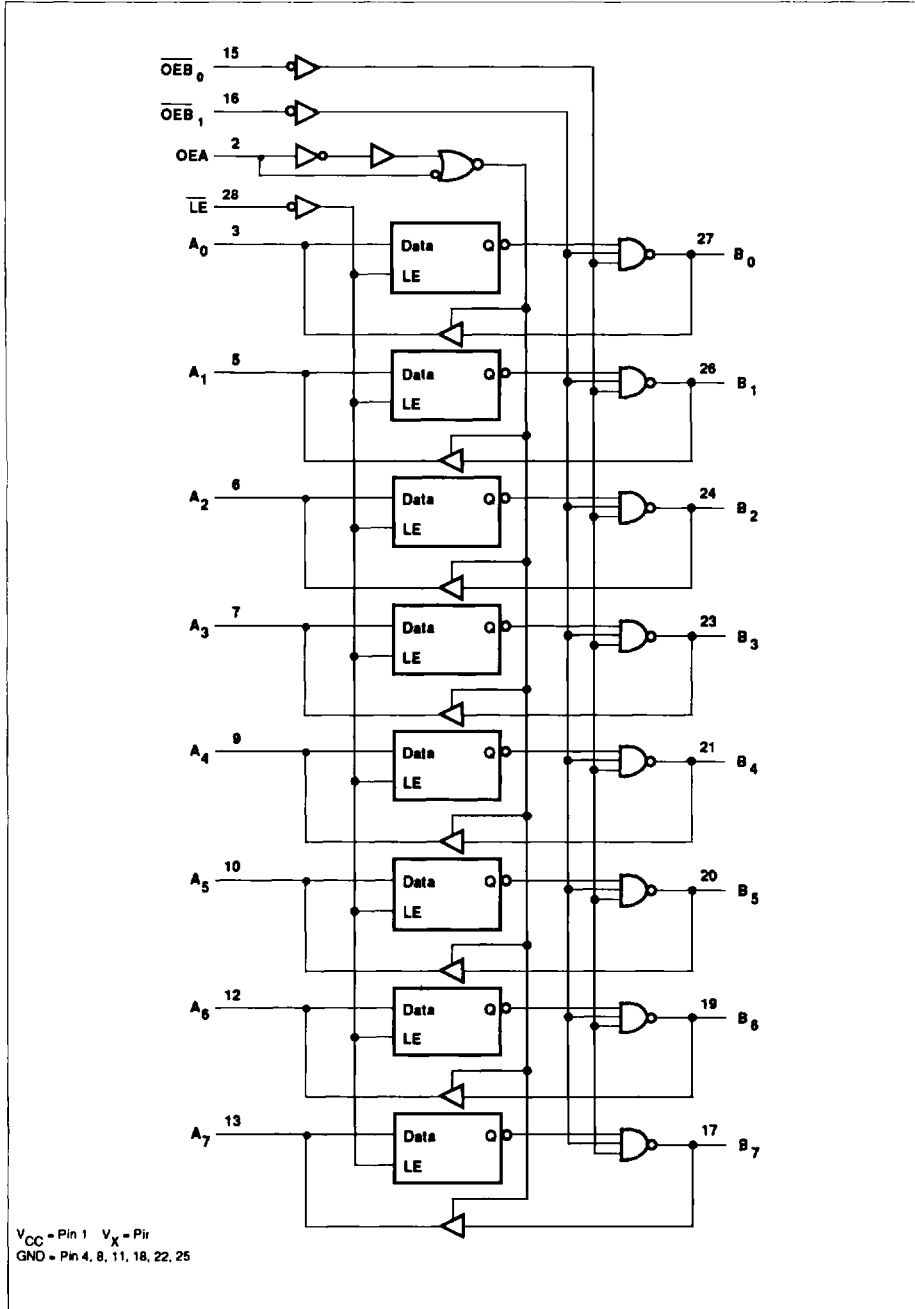

Futurebus Transceivers

FAST 74F8960, 74F8961

FUNCTION TABLE 74F8960

INPUTS						LATCH	OUTPUTS		MODE
A _n	B _n *	LE	OEA	\overline{OEB}_0	\overline{OEB}_1	STATE	A _n	B _n	
H	X	L	L	L	L	H	Z	L	A 3-state, Data from A to B
L	X	L	L	L	L	L	Z	H**	
X	X	H	L	L	L	Q _n	Z	\overline{Q}_n	A 3-state, Latched data to B
-	-	L	H	L	L	(1)	(1)	(1)	Feedback: A to B, B to A
-	H	H	H	L	L	L ⁽²⁾	L	Z ⁽²⁾	Preconditioned Latch enabling data transfer from B to A
-	L	H	H	L	L	L ⁽²⁾	H	Z ⁽²⁾	
-	-	H	H	L	L	Q _n	\overline{Q}_n	\overline{Q}_n	Latch state to A and B
H	X	L	L	H	X	H	Z	Z	B and A 3-state
L	X	L	L	H	X	L	Z	Z	
X	X	H	L	H	X	Q _n	Z	Z	
-	H	L	H	H	X	H	L	Z	B 3-state, Data from B to A
-	L	L	H	H	X	L	H	Z	
-	H	H	H	H	X	Q _n	L	Z	
-	L	H	H	H	X	Q _n	H	Z	
H	X	L	L	X	H	H	Z	Z	B and A 3-state
L	X	L	L	X	H	L	Z	Z	
X	X	H	L	X	H	Q _n	Z	Z	
-	H	L	H	X	H	H	L	Z	B 3-state, Data from B to A
-	L	L	H	X	H	L	H	Z	
-	H	H	H	X	H	Q _n	L	Z	
-	L	H	H	X	H	Q _n	H	Z	

H = High voltage level

L = Low voltage level

X = Don't care

- = Input not externally driven

Z = High Impedance (off) state

Q_n = High or Low voltage level one setup time prior to the Low-to-High LE transition

(1) = Condition will cause a feedback loop path; A to B and B to A

(2) = The latch must be preconditioned such that B inputs may assume a High or Low level while \overline{OEB}_0 and \overline{OEB}_1 are Low and LE is High.

H** = Goes to level of pullup voltage.

B* = Precaution should be taken to insure B inputs do not float. If they do they are equal to Low state.

Futurebus Transceivers

FAST 74F8960, 74F8961

FUNCTION TABLE. 74F8961

INPUTS						LATCH	OUTPUTS		MODE
A _n	B _n *	LE	OEA	\overline{OEB}_0	\overline{OEB}_1	STATE	A _n	B _n	
H	X	L	L	L	L	H	Z	H**	A 3-state, Data from A to B
L	X	L	L	L	L	L	Z	L	
X	X	H	L	L	L	Q _n	Z	Q _n	A 3-state, Latched data to B
-	-	L	H	L	L	(1)	(1)	(1)	Feedback: A to B, B to A
-	H	H	H	L	L	H ⁽²⁾	H	Z ⁽²⁾	Preconditioned Latch enabling data transfer from B to A
-	L	H	H	L	L	H ⁽²⁾	L	Z ⁽²⁾	
-	-	H	H	L	L	Q _n	Q _n	Q _n	Latch state to A and B
H	X	L	L	H	X	H	Z	Z	B and A 3-state
L	X	L	L	H	X	L	Z	Z	
X	X	H	L	H	X	Q _n	Z	Z	
-	H	L	H	H	X	H	H	Z	B 3-state, Data from B to A
-	L	L	H	H	X	L	L	Z	
-	H	H	H	H	X	Q _n	H	Z	
-	L	H	H	H	X	Q _n	L	Z	
H	X	L	L	X	H	H	Z	Z	B and A 3-state
L	X	L	L	X	H	L	Z	Z	
X	X	H	L	X	H	Q _n	Z	Z	
-	H	L	H	X	H	H	H	Z	B 3-state, Data from B to A
-	L	L	H	X	H	L	L	Z	
-	H	H	H	X	H	Q _n	H	Z	
-	L	H	H	X	H	Q _n	L	Z	

H = High voltage level

L = Low voltage level

X = Don't care

- = Input not externally driven

Z = High Impedance (off) state

Q_n = High or Low voltage level one setup time prior to the Low-to-High LE transition

(1) = Condition will cause a feedback loop path; A to B and B to A

(2) = The latch must be preconditioned such that B inputs may assume a High or Low level while \overline{OEB}_0 and \overline{OEB}_1 are Low and LE is High.

H** = Goes to level of pullup voltage.

B* = Precaution should be taken to insure B inputs do not float. If they do they are equal to Low state.

Futurebus Transceivers

FAST 74F8960, 74F8961

ABSOLUTE MAXIMUM RATINGS (Operation beyond the limits set forth in this table may impair the useful life of the device. Unless otherwise noted these limits are over the operating free-air temperature range.)

SYMBOL	PARAMETER	RATING	UNIT
V_{CC}	Supply voltage	-0.5 to +7.0	V
V_X	Threshold control	-0.5 to +7.0	V
V_{IN}	Input voltage	$\overline{OE}, \overline{B}_n, \overline{OEA}, \overline{LE}$	-0.5 to +7.0
		$A_0 - A_7, B_0 - B_7$	-0.5 to 5.5
I_{IN}	Input current	-40 to +5	mA
V_{OUT}	Voltage applied to output in High output state	-0.5 to + V_{CC}	V
I_{OUT}	Current applied to output in Low output state	$A_0 - A_7$	48
		$B_0 - B_7$	200
T_A	Operating free-air temperature range	0 to +70	°C
T_{STG}	Storage temperature	-65 to +150	°C

RECOMMENDED OPERATING CONDITIONS

SYMBOL	PARAMETER	LIMITS			UNIT
		Min	Nom	Max	
V_{CC}	Supply voltage	4.5	5.0	5.5	V
V_{IH}	High-level input voltage	Except $B_0 - B_7$	2.0		V
		$B_0 - B_7$	1.625		
V_{IL}	Low-level input voltage	Except $B_0 - B_7$		0.8	V
		$B_0 - B_7$		1.475	
I_{IK}	Input clamp current	Except $A_0 - A_7$		-18	mA
		$A_0 - A_7$		-40	
I_{OH}	High-level output current	$A_0 - A_7$		-3	mA
I_{OL}	Low-level output current	$A_0 - A_7$		24	mA
		$B_0 - B_7$		100	
T_A	Operating free-air temperature range	0		70	°C

Futurebus Transceivers

FAST 74F8960, 74F8961

DC ELECTRICAL CHARACTERISTICS (Over recommended operating free-air temperature range unless otherwise noted.)

SYMBOL	PARAMETER	TEST CONDITIONS ¹	LIMITS			UNIT	
			Min	Typ ²	Max		
I_{OH}	High level output current	$B_0 - B_7$ $V_{CC} = \text{MAX}, V_{IL} = \text{MAX}, V_{IH} = \text{MIN}, V_{OH} = 2.1\text{V}$			100	μA	
I_{OFF}	Power-off output current	$B_0 - B_7$ $V_{CC} = 0.0\text{V}, V_{IL} = \text{MAX}, V_{IH} = \text{MIN}, V_{OH} = 2.1\text{V}$			100	μA	
V_{OH}	High-level output voltage	$A_0 - A_7$ ⁴ $V_{CC} = \text{MIN}, V_{IL} = \text{MAX}, V_{IH} = \text{MIN}$	$I_{OH} = -3\text{mA}, V_X = V_{CC}$	2.5		V_{CC}	V
			$I_{OH} = -0.4\text{mA}, V_X = 3.13\text{V} \ \& \ 3.47\text{V}$	2.5		V_X	V
V_{OL}	Low-level output voltage	$A_0 - A_7$ ⁴ $B_0 - B_7$	$V_{CC} = \text{MIN}, V_{IL} = \text{MAX}, V_{IH} = \text{MIN}$			0.5	V
			$V_{CC} = \text{MIN}, V_{IL} = \text{MAX}, V_{IH} = \text{MIN}$			1.15	V
V_{IK}	Input clamp voltage	$A_0 - A_7$	$V_{CC} = \text{MIN}, I_I = I_{IK}$			-0.5	V
		Except $A_0 - A_7$	$V_{CC} = \text{MIN}, I_I = I_{IK}$			-1.2	V
I_I	Input current at maximum input voltage	$\overline{OEB}_n, \text{OEA}, \overline{LE}$	$V_{CC} = 0.0\text{V}, V_I = 7.0\text{V}$			100	μA
		$A_0 - A_7, B_0 - B_7$	$V_{CC} = \text{MAX}, V_I = 5.5\text{V}$			1	mA
I_{IH}	High-level input current	$\overline{OEB}_n, \text{OEA}, \overline{LE}$	$V_{CC} = \text{MAX}, V_I = 2.7\text{V}, B_n - A_n = 0\text{V}$			20	μA
		$B_0 - B_7$	$V_{CC} = \text{MAX}, V_I = 2.1\text{V}$			100	μA
I_{IL}	Low-level input current	$\overline{OEB}_n, \text{OEA}, \overline{LE}$	$V_{CC} = \text{MAX}, V_I = 0.5\text{V}$			-20	μA
		$B_0 - B_7$	$V_{CC} = \text{MAX}, V_I = 0.3\text{V}$			-100	μA
$I_{OZH} + I_{IH}$	Off-state output current, High-level voltage applied	$A_0 - A_7$	$V_{CC} = \text{MAX}, V_O = 2.7\text{V}$			70	μA
$I_{OZL} + I_{IL}$	Off-state output current, Low-level voltage applied	$A_0 - A_7$	$V_{CC} = \text{MAX}, V_O = 0.5\text{V}$			-70	μA
I_X	High-level control current		$V_{CC} = \text{MAX}, V_X = V_{CC}, \overline{LE} = \text{OEA} = \overline{OEB}_n = 2.7\text{V}, A_0 - A_7 = 2.7\text{V}, B_0 - B_7 = 2.0\text{V}$	-100		100	μA
			$V_{CC} = \text{MAX}, V_X = 3.13\text{V} \ \& \ 3.47\text{V}, \overline{LE} = \text{OEA} = 2.7\text{V}, \overline{OEB}_n = A_0 - A_7 = 2.7\text{V}, B_0 - B_7 = 2.0\text{V}$	-10		10	mA
I_{OS}	Short-circuit output current ³	$A_0 - A_7$ only	$V_{CC} = \text{MAX}, B_n = 1.6\text{V}, \text{OEA} = 2.0\text{V}, \overline{OEB}_n = 2.7\text{V}$	-60		-150	mA
I_{CC}	Supply current (total)	I_{CCH}	$V_{CC} = \text{MAX}$		70	100	mA
		I_{CCL}	$V_{CC} = \text{MAX}, V_{IL} = 0.5\text{V}$		100	145	mA
		I_{CCZ}	$V_{CC} = \text{MAX}, V_{IL} = 0.5\text{V}$		80	100	mA

NOTES:

- For conditions shown as MIN or MAX, use the appropriate value specified under recommended operating conditions for the applicable type. Unless otherwise specified, $V_X = V_{CC}$ for all test conditions.
- All typical values are at $V_{CC} = 5\text{V}, T_A = 25^\circ\text{C}$.
- Not more than one output should be shorted at a time. For testing I_{OS} , the use of high-speed test apparatus and/or sample-and-hold techniques are preferable in order to minimize internal heating and more accurately reflect operational values. Otherwise, prolonged shorting of a High output may raise the chip temperature well above normal and thereby cause invalid readings in other parameter tests. In any sequence of parameter tests, I_{OS} tests should be performed last.
- Due to test equipment limitations, actual test conditions are for $V_{IH} = 1.6\text{V}$ and $V_{IL} = 1.3\text{V}$.

Futurebus Transceivers

FAST 74F8960, 74F8961

AC ELECTRICAL CHARACTERISTICS for 74F8960

SYMBOL	PARAMETER	TEST CONDITION	A PORT LIMITS					UNIT
			$T_A = +25^\circ\text{C}$ $V_{CC} = 5\text{V}$ $C_L = 50\text{pF}$ $R_L = 500\Omega$			$T_A = 0^\circ\text{C to } +70^\circ\text{C}$ $V_{CC} = 5\text{V} \pm 10\%$ $C_L = 50\text{pF}$ $R_L = 500\Omega$		
			Min	Typ	Max	Min	Max	
t_{PLH} t_{PHL}	Propagation delay B to A	Waveform 1, 2	5.5 6.0	7.5 7.5	12.0 10.5	5.0 6.0	12.0 11.0	ns
t_{PZH} t_{PZL}	Output Enable time from High or Low OEA to A	Waveform 4.5	8.0 8.5	10.5 12.0	14.5 14.5	7.5 8.5	15.5 17.0	ns
t_{PHZ} t_{PLZ}	Output Disable time to High or Low OEA to A	Waveform 4.5	2.0 2.0	4.5 4.5	7.0 7.5	2.0 2.0	7.5 8.0	ns
SYMBOL	PARAMETER	TEST CONDITION	B PORT LIMITS					UNIT
			$T_A = +25^\circ\text{C}$ $V_{CC} = 5\text{V}$ $C_D = 30\text{pF}$ $R_U = 9\Omega$			$T_A = 0^\circ\text{C to } +70^\circ\text{C}$ $V_{CC} = 5\text{V} \pm 10\%$ $C_D = 30\text{pF}$ $R_U = 9\Omega$		
			Min	Typ	Max	Min	Max	
t_{PLH} t_{PHL}	Propagation delay A to B	Waveform 1, 2	2.0 3.5	4.0 6.0	7.0 8.0	2.0 3.0	8.0 9.0	ns
t_{PLH} t_{PHL}	Propagation delay $\overline{\text{LE}}$ to B	Waveform 1, 2	3.0 4.0	5.0 6.0	8.5 9.0	2.5 3.0	10.0 9.5	ns
t_{PLH} t_{PHL}	Enable/disable time $\overline{\text{OEB}}$ to B	Waveform 1, 2	2.5 4.5	4.5 7.5	7.5 10.5	1.5 3.5	8.5 10.5	ns
t_{TLH} t_{THL}	Transition time, B Port 1.3V to 1.7 V, 1.7V to 1.3V	Test Circuit and Waveforms	0.5 0.5	2.0 2.0	4.5 4.5	0.5 0.5	4.5 4.5	ns

AC SETUP REQUIREMENTS for 74F8960

SYMBOL	PARAMETER	TEST CONDITION	LIMITS					UNIT
			$T_A = +25^\circ\text{C}$ $V_{CC} = 5\text{V}$ $C_L = 50\text{pF}$ $R_L = 500\Omega$			$T_A = 0^\circ\text{C to } +70^\circ\text{C}$ $V_{CC} = 5\text{V} \pm 10\%$ $C_L = 50\text{pF}$ $R_L = 500\Omega$		
			Min	Typ	Max	Min	Max	
$t_s(H)$ $t_s(L)$	Set-up time A to $\overline{\text{LE}}$	Waveform 3	5.0 5.0			5.0 5.0		ns
$t_h(H)$ $t_h(L)$	Hold time A to $\overline{\text{LE}}$	Waveform 3	0.0 0.0			0.0 0.0		ns
$t_w(L)$	$\overline{\text{LE}}$ pulse width, Low	Waveform 3	6.0			6.0		ns

Futurebus Transceivers

FAST 74F8960, 74F8961

AC ELECTRICAL CHARACTERISTICS for 74F8961

SYMBOL	PARAMETER	TEST CONDITION	A PORT LIMITS					UNIT
			$T_A = +25^\circ\text{C}$ $V_{CC} = 5\text{V}$ $C_L = 50\text{pF}$ $R_L = 500\Omega$			$T_A = 0^\circ\text{C to } +70^\circ\text{C}$ $V_{CC} = 5\text{V} \pm 10\%$ $C_L = 50\text{pF}$ $R_L = 500\Omega$		
			Min	Typ	Max	Min	Max	
t_{PLH} t_{PHL}	Propagation delay B to A	Waveform 1, 2	5.5 6.0	7.5 7.5	12.0 10.5	5.0 6.0	12.0 11.0	ns
t_{PZH} t_{PZL}	Output Enable time from High or Low OEA to A	Waveform 4.5	8.0 8.5	10.5 12.0	14.5 14.5	7.5 8.5	15.5 17.0	ns
t_{PHZ} t_{PLZ}	Output Disable time to High or Low OEA to A	Waveform 4.5	2.0 2.0	4.5 4.5	7.0 7.5	2.0 2.0	7.5 8.0	ns
SYMBOL	PARAMETER	TEST CONDITION	B PORT LIMITS					UNIT
			$T_A = +25^\circ\text{C}$ $V_{CC} = 5\text{V}$ $C_D = 30\text{pF}$ $R_U = 9\Omega$			$T_A = 0^\circ\text{C to } +70^\circ\text{C}$ $V_{CC} = 5\text{V} \pm 10\%$ $C_D = 30\text{pF}$ $R_U = 9\Omega$		
			Min	Typ	Max	Min	Max	
t_{PLH} t_{PHL}	Propagation delay A to B	Waveform 1, 2	2.0 3.5	4.0 6.0	7.0 8.0	2.0 3.0	8.0 9.0	ns
t_{PLH} t_{PHL}	Propagation delay $\overline{\text{LE}}$ to B	Waveform 1, 2	3.0 4.0	5.0 6.0	8.5 9.0	2.5 3.0	10.0 9.5	ns
t_{PLH} t_{PHL}	Enable/disable time $\overline{\text{OEB}}_n$ to B	Waveform 1, 2	2.5 4.5	4.5 7.5	7.5 10.5	1.5 3.5	8.5 10.5	ns
t_{TLH} t_{THL}	Transition time, B Port 1.3V to 1.7 V, 1.7V to 1.3V	Test Circuit and Waveforms	0.5 0.5	2.0 2.0	4.5 4.5	0.5 0.5	4.5 4.5	ns

AC SETUP REQUIREMENTS for 74F8961

SYMBOL	PARAMETER	TEST CONDITION	LIMITS					UNIT
			$T_A = +25^\circ\text{C}$ $V_{CC} = 5\text{V}$ $C_L = 50\text{pF}$ $R_L = 500\Omega$			$T_A = 0^\circ\text{C to } +70^\circ\text{C}$ $V_{CC} = 5\text{V} \pm 10\%$ $C_L = 50\text{pF}$ $R_L = 500\Omega$		
			Min	Typ	Max	Min	Max	
$t_s(H)$ $t_s(L)$	Set-up time A to $\overline{\text{LE}}$	Waveform 3	5.0 5.0			5.0 5.0		ns
$t_h(H)$ $t_h(L)$	Hold time A to $\overline{\text{LE}}$	Waveform 3	0.0 0.0			0.0 0.0		ns
$t_w(L)$	$\overline{\text{LE}}$ pulse width, Low	Waveform 3	6.0			6.0		ns

Futurebus Transceivers

FAST 74F8960, 74F8961

AC WAVEFORMS

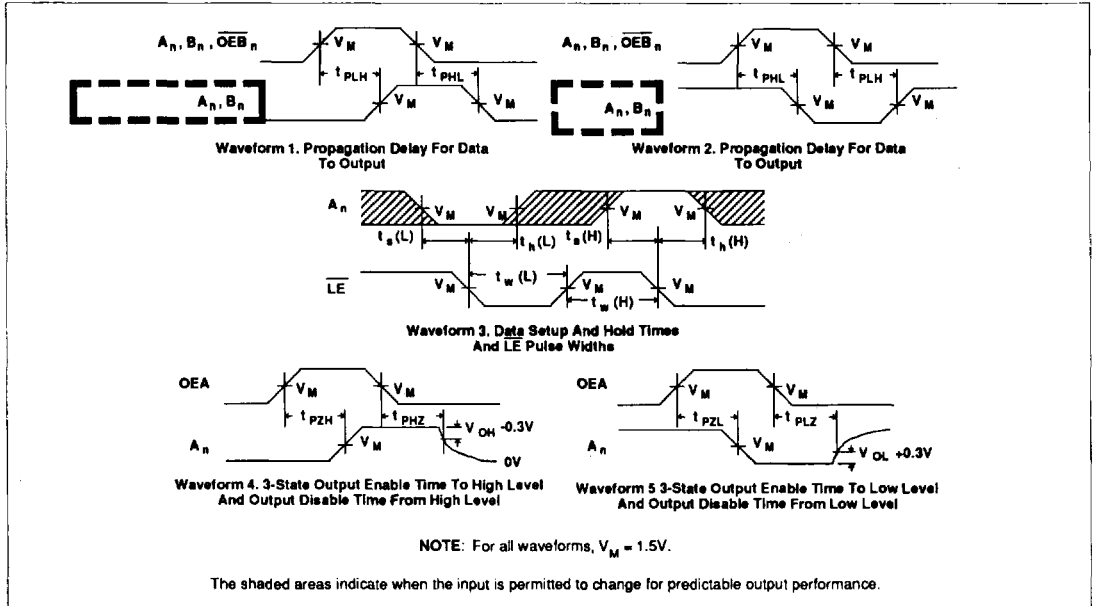

TEST CIRCUIT AND WAVEFORMS

