

PRODUCT NUMBER  
SEE NOTE 1

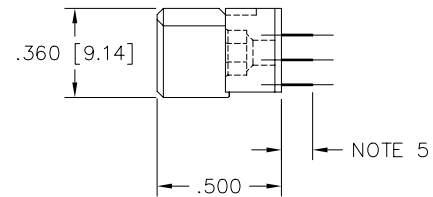

mat'l. code NOTE 3		surface ISO 1302 ✓		tolerance ISO 406 ISO 1101		projection ⊕		product family HPC	
ltr		ecn no dr		date		tolerances unless otherwise specified		title	
A		v12494 SAR		9/09/91		angles linear .xx ±.01/.3		3 ROW VERTICAL RECEPT.	
B		v31616 SRS		10/26/93		.xxx ±.005/.13		HIGH DURABILITY, S.T.B., 0 G.P.	
C		v40678 GIP		3/29/94		σ±2' .xxxx ±.0020/.051		scale 1:1	
D		v90521 HTB		2/25/99		dr S. ROYER 8/16/91		dwg no sheet 1 of 2 size	
E		v00258 JWS		1/21/00		engr S. CLARK 8/16/91		50022 A3	
F		M06-0255 MNR		7/06/06		chr S. CLARK 8/16/91		type Product Customer Drawing	
		appd S. CLARK		8/16/91					
sheet index		revision sheet		F F		1 2			

PRODUCT NUMBER	DIM.	LENGTH FORMULAS
SEE NOTE 1	DIM A	.100/2.54 X NO. OF COLUMNS + .75/19.1
	DIM B	.100/2.54 X NO. OF COLUMNS + .450/11.4
	DIM C	.100/2.54 X NO. OF COLUMNS - .100/2.5

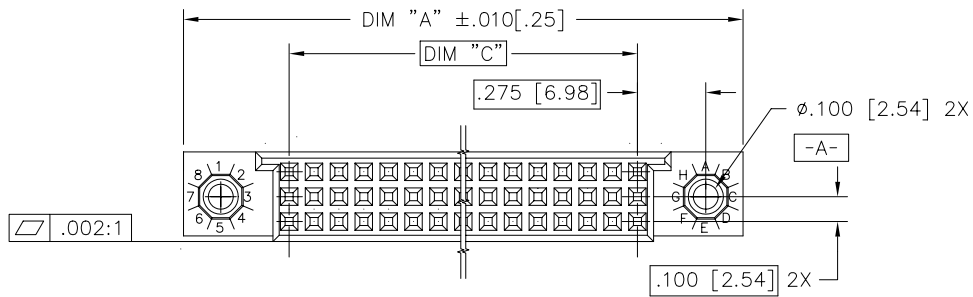
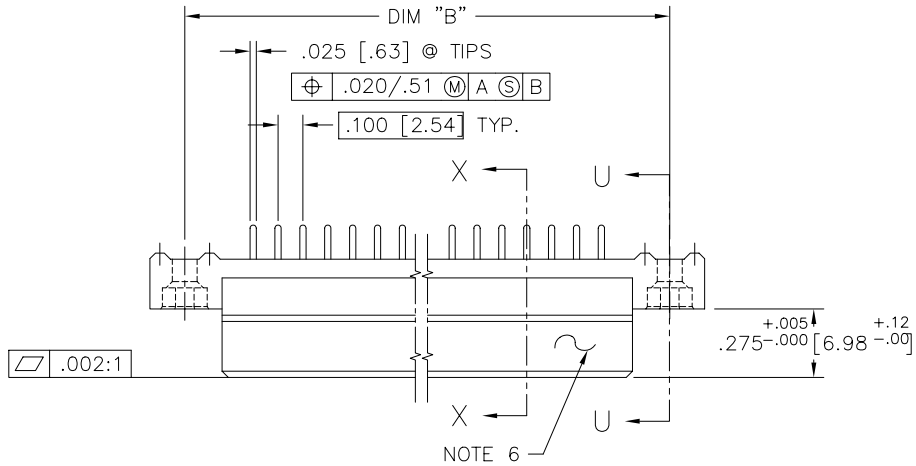
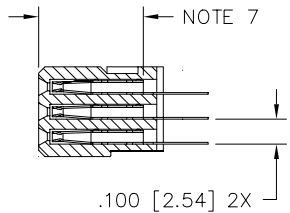

SECTION X-X

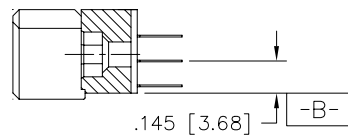

SECTION U-U

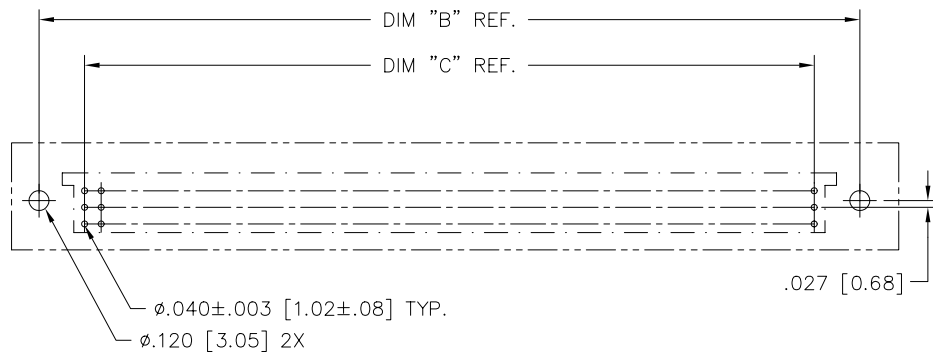

RECOMMENDED PCB LAYOUT  
(ALL HOLES LOCATED ON .100/2.54 GRID UNLESS OTHERWISE SPECIFIED)

NOTES:

- PRODUCT NUMBERING CODE:  
50022 - X YYY Z  
TAIL LENGTH(NOTE 5)  
NO. OF POSITIONS(NOTE 2)  
PLATING(NOTE 4)  
BASE NUMBER
- THIS PRODUCT IS CONFIGURED IN SIZES OF 10 THRU 80 COLUMNS IN INCREMENTS OF ONE. i.e.: 10,11,12,13,.....79,80.
- HOUSING MATERIAL: GLASS AND MINERAL FILLED HIGH TEMP. THERMOPLASTIC. FLAME RETARDANT PER UL94V-0. COLOR: BLACK. CONTACT MATERIAL: BeCu
- PLATING CONTACT AREA OPTIONS:  
7 = 60u"/1.52u GXT  
ALL SOLDER TAILS TIN/LEAD.
- TAIL LENGTH OPTIONS:  
E = .125±.010 / 3.18±.25  
F = .145±.010 / 3.68±.25  
H = .180±.010 / 4.57±.25
- MANUFACTURE'S NAME, P/N AND LOT CODE TO APPEAR ON THIS SURFACE AS PER BUS-12-108.
- FOR DOCUMENTATION MENU, SEE BUS-01-057.

mat'l. code		surface ISO 1302 ✓ ISO 406 ISO 1101	tolerance ISO 406 ISO 1101	projection ⊕	product family HPC
ltr	ecn	no	dr	date	tolerances unless otherwise specified
F					angles linear .xx ±.01/.3 .xxx ±.005/.13 0°±2' .xxxx ±.0020/.051
					INCH/MM scale 1:1
					title 3 ROW VERTICAL RECEPT. HIGH DURABILITY, S.T.B., 0 G.P.
					dwg no 50022
					sheet 2 of 2 size A3
					type Product Customer Drawing
sheet index	revision sheet				

FCI  
FCIconnect.com  
Copyright FCI