

KA7525B

Power Factor Correction Controller

Features

- Internal Start-up Timer
- Internal Current Sense Blanking Which Eliminates the Need for an External R/C filter
- Overvoltage Comparator Eliminates Runaway Output Voltage
- Zero Current Detector
- One Quadrant Multiplier
- Trimmed 1.5% Internal Bandgap Reference
- Under Voltage Lock Out with 2.1V of Hysteresis
- Totem Pole Output with High State Clamp
- Low Start-up and Operating Current
- 8-Pin DIP or 8-Pin SOP.

Applications

- Electronic Ballast
- SMPS

Description

The KA7525B provides simple and high performance active power factor correction. KA7525B is optimized for electronic ballast and low power, high density power supplies requiring a minimum board area, reduced component count and low power dissipation. Addition of internal current sense blanking (Internal R,C) eliminates the need for an external R/C filter. Internal clamping of the error amplifier and multiplier outputs improves turn on overshoot characteristics and current limiting. Special circuitry has also been added to prevent no load runaway conditions. Output drive clamps limiting power MOSFET gate drive independent of supply voltage greatly enhance the products practical application.

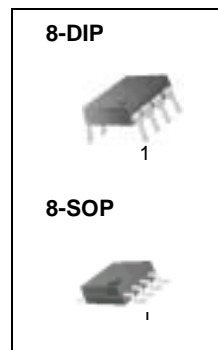

Pin Assignments

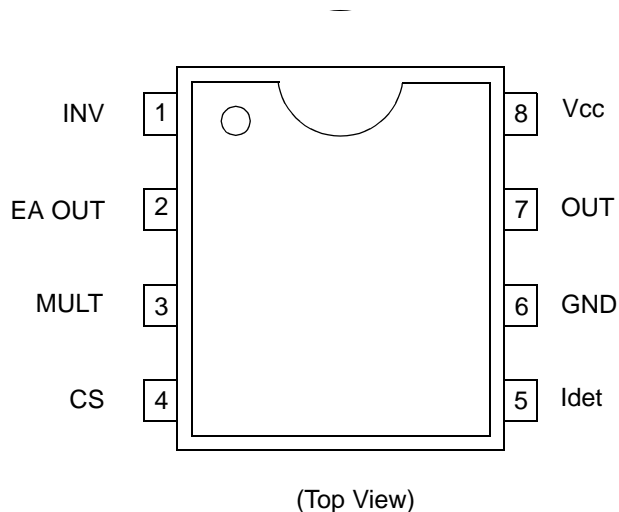

Pin Definitions

| Pin Number | Pin Name | Pin Function Description |
|------------|----------|--|
| 1 | INV | Inverting input of the error amplifier. The output of the Boost converter should be resistively divided to 2.5V and connected to this pin. |
| 2 | EA_OUT | The output of the error amplifier. A feedback compensation network is placed between this pin and the INV pin. |
| 3 | MULT | Input of the multiplier stage. The full-wave rectified AC is divided to less than 2V and is connected to this pin. |
| 4 | CS | Input of the PWM comparator. Current is sensed in the Boost stage MOSFET by a resistor in the source lead. An internal leading edge blanking circuitry has been included to reject any high frequency noise present on the current waveform. |
| 5 | Idet | The zero current detector senses the inductor current by monitoring when the Boost inductor auxiliary winding voltage falls below 1.8V. |
| 6 | GND | The ground potential of all the pins. |
| 7 | OUT | The output of a high current power driver capable of driving the gate of a power MOSFET. |
| 8 | Vcc | The logic and control power supply connection. |

Internal Block Diagram

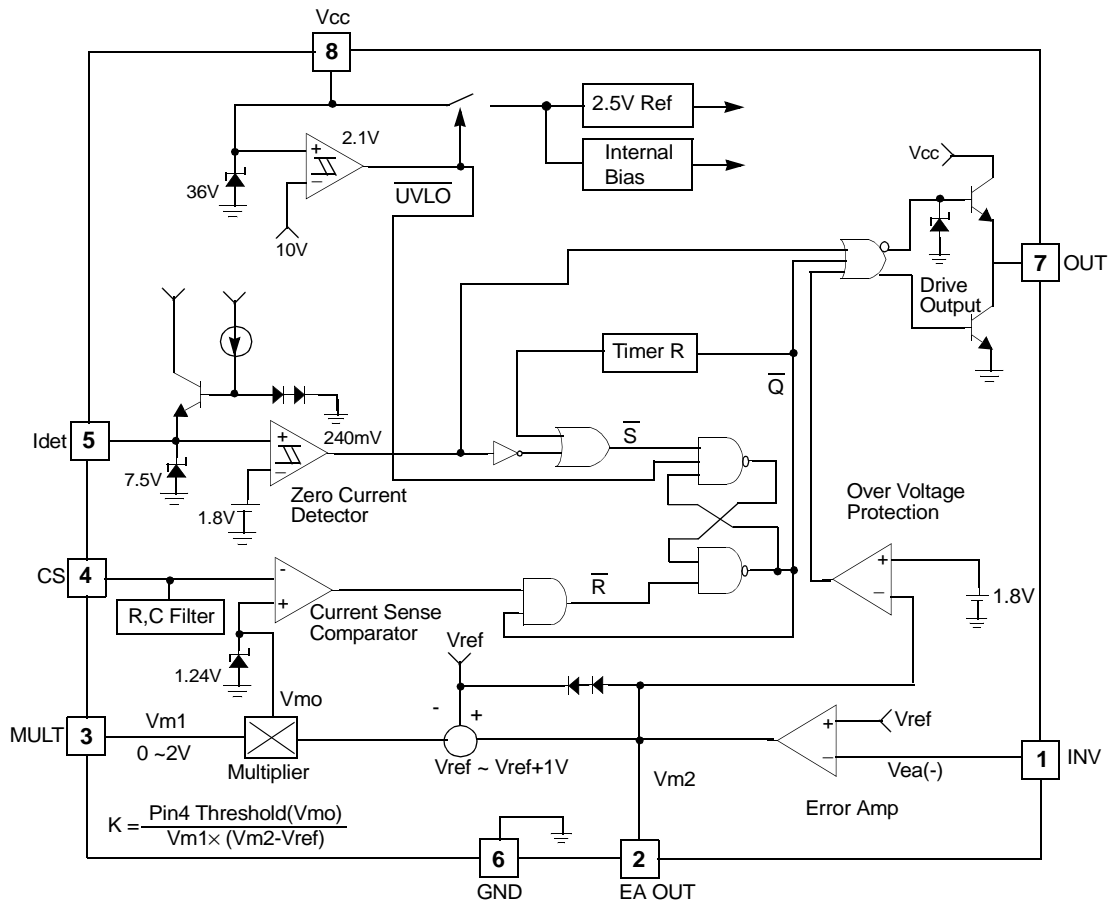

Absolute Maximum Ratings

| Parameter | Symbol | Value | Unit |
|---|-----------------------------------|------------|------|
| Supply Voltage | VCC | 30 | V |
| Peak Drive Output Current | I _{oh} , I _{ol} | ±500 | mA |
| Driver Output Clamping Diodes V _O > V _{CC} or V _O < -0.3V | I _{clamp} | ±10 | mA |
| Detector Clamping Diodes | I _{det} | ±10 | mA |
| Error Amp, Multiplier and Comparator Input Voltage | V _{in} | -0.3 to 6 | V |
| Operating Temperature Range | T _{opr} | 0 to 125 | °C |
| Storage Temperature Range | T _{stg} | -65 to 150 | °C |
| Power Dissipation | P _d | 0.8 | W |
| Thermal Resistance (Junction-to-Air) | R _{θja} | 100 | °C/W |

Temperature Characteristics (0°C ≤ T_a ≤ 125°C)

| Characteristics | Symbol | Value | Unit |
|--|-------------------------|-------|------|
| Temperature Stability for Reference Voltage(V _{ref}) | ΔV _{ref} (Typ) | 20 | mV |
| Temperature Stability for Multiplier Gain(K) | ΔK/ΔT (Typ) | -0.2 | %/°C |

Electrical Characteristics

Unless otherwise specified, these specifications apply over the operating ambient temperatures for the KA7525B with $0^{\circ}\text{C} \leq T_a \leq 125^{\circ}\text{C}$ and $V_{cc}=12\text{V}$.

| Parameter | Symbol | Conditions | Min. | Typ. | Max. | Unit |
|--|---------------------|--|-----------|------|-------------|------------------------|
| UNDER VOLTAGE LOCK OUT SECTION | | | | | | |
| Start Threshold Voltage | $V_{th(st)}$ | V_{cc} Increasing | 9 | 10 | 11 | V |
| UVLO Hysteresis | $H_{Y(st)}$ | - | 1.7 | 2.1 | 2.5 | V |
| Supply Zener Voltage | V_z | $I_{cc}=10\text{mA}$ | 30 | 36 | - | V |
| SUPPLY CURRENT SECTION | | | | | | |
| Start-Up Supply Current | I_{st} | $V_{cc} < V_{th(st)}$ | - | 0.2 | 0.3 | mA |
| Operating Supply Current | I_{cc} | No Output Switching | - | 4 | 8 | mA |
| Dynamic Operating Supply Current | I_{dcc} | 50kHz, $C_I = 1\text{nF}$ | - | 5 | 10 | mA |
| ERROR AMPLIFIER SECTION | | | | | | |
| Voltage Feedback Input Threshold | V_{ref} | $I_{ref}=0\text{mA}$ | 2.465 | 2.5 | 2.535 | V |
| | | $0^{\circ}\text{C} \leq T_a \leq 125^{\circ}\text{C}$ | 2.44 | - | 2.56 | V |
| Line Regulation | ΔV_{ref1} | $12\text{V} \leq V_{cc} \leq 25\text{V}$ | - | 0.1 | 10 | mV |
| Load Regulation (Note1) | ΔV_{ref2} | $0\text{mA} \leq I_{ref} \leq 2\text{mA}$ | - | 0.1 | 10 | mV |
| Temperature Stability of V_{ref} (Note2) | ΔV_{ref3} | $0^{\circ}\text{C} \leq T_a \leq 125^{\circ}\text{C}$ | - | 20 | - | mV |
| Input Bias Current | $I_{b(ea)}$ | - | -0.5 | - | 0.5 | μA |
| Output Source Current | I_{source} | $V_{m2}=3\text{V}$ | -2 | -4.5 | - | mA |
| Output Sink Current | I_{sink} | $V_{m2}=2\text{V}$ | 3 | 4.5 | - | mA |
| Output Voltage Range (Note2) | ΔV_{eao} | No Load on EA Out | 1.2 | - | 3.6 | V |
| Slew Rate (Note2) | SR | - | - | 0.6 | - | $\text{V}/\mu\text{s}$ |
| MULTIPLIER SECTION | | | | | | |
| Input Bias Current(Pin3) | $I_{b(m)}$ | - | -0.5 | - | 0.5 | μA |
| M1 Input Voltage Range (Pin3) | ΔV_{m1} | - | 0 | - | 2 | V |
| M2 Input Voltage Range (Pin2) | ΔV_{m2} | - | V_{ref} | - | $V_{ref}+1$ | V |
| Multiplier Gain(Note3) | K | $V_{m1}=1\text{V}$, $\Delta V_{m2}= 2.7$ to 3.3V | 0.55 | 0.68 | 0.8 | 1/V |
| Maximum Multiplier Output Voltage | $V_{omax(m)}$ | $V_{ea(-)} = 0\text{V}$, $V_{m1}=2\text{V}$ | 1.1 | 1.24 | 1.45 | V |
| Temperature Stability of K (Note2) | $\Delta K/\Delta T$ | $0^{\circ}\text{C} \leq T_a \leq 125^{\circ}\text{C}$ | - | -0.2 | - | $\%/^{\circ}\text{C}$ |

Electrical Characteristics (Continued)

| Parameter | Symbol | Conditions | Min. | Typ. | Max. | Unit |
|---|-----------------------|--|------|------|------|------|
| CURRENT SENSE SECTION | | | | | | |
| Input Offset Voltage (Note2) | V _{io(cs)} | V _{m1} = 0V, V _{m2} = 2.2V | -10 | 3 | 10 | mV |
| Input Bias Current | I _{b(cs)} | 0V ≤ V _{cs} ≤ 1.7V | -1 | -0.3 | 1 | μA |
| Current Sense Delay to Output (Note2) | t _{d(cs)} | - | - | 200 | 500 | ns |
| ZERO CURRENT DETECT SECTION | | | | | | |
| Detect Input Threshold | V _{th(det)} | V _{det} Increasing | 1.65 | 1.8 | 1.95 | V |
| Detect Hysteresis | H _{Y(det)} | - | 180 | 240 | 300 | mV |
| Input Low Clamp Voltage | V _{clamp(l)} | I _{det} = -100μA | 0.45 | 0.75 | 1 | V |
| Input High Clamp Voltage | V _{clamp(h)} | I _{det} = 3mA | 6.7 | 7.5 | 8.3 | V |
| Input Bias Current | I _{b(det)} | 1V ≤ V _{det} ≤ 6V | -1 | -0.2 | 1 | μA |
| Input High/Low Clamp Diode Current(Note2) | I _{clamp(d)} | - | - | - | ±3 | mA |
| OUTPUT DRIVER SECTION | | | | | | |
| Output Voltage High | V _{oh} | I _O = -10mA, V _{CC} = 12V | 8.5 | 9 | - | V |
| Output Voltage Low | V _{ol} | I _O = 10mA, V _{CC} = 12V | - | 0.8 | 1 | V |
| Rising Time(Note2) | t _r | C _I = 1nF | - | 130 | 200 | ns |
| Falling Time(Note2) | t _f | C _I = 1nF | - | 50 | 120 | ns |
| Maximum Output Voltage | V _{omax(o)} | V _{CC} = 20V | 12 | 13 | 15 | V |
| Output Voltage With UVLO Activated | V _{omin(o)} | V _{CC} = 5V, I _O = 100μA | - | - | 1 | V |
| RESTART TIMER SECTION | | | | | | |
| Restart Time Delay | t _{d(rst)} | V _{m1} = 1V, V _{m2} = 3.5V | - | 300 | - | μs |
| OVER VOLTAGE PROTECTION SECTION | | | | | | |
| Voltage Feedback Input Threshold | V _{th(ovp)} | V _{cs} = -0.5V, V _{m1} = 1V, V _{det} = 0V | 1.7 | 1.8 | 1.9 | V |

Notes :

1. Because the reference is not brought out externally, this specification cannot be tested on the package part. It is guaranteed by design.
2. These parameters, although guaranteed, are not 100% tested in production.

$$3. K = \frac{\text{Pin4 Threshold}}{V_{m1} \times (V_{m2} - V_{ref})} \quad (V_{m1} = V_{pin3}, V_{m2} = V_{pin2})$$

Typical Performance Characteristics

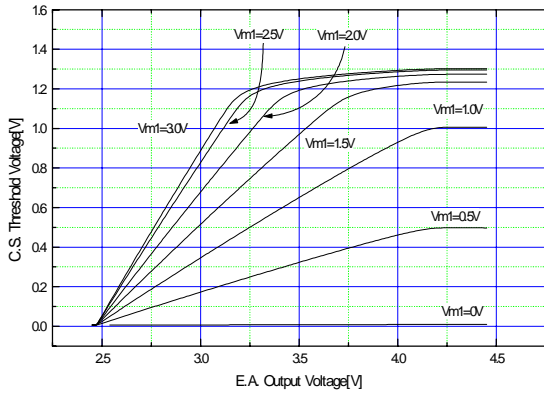

Figure 1. E.A. Output Voltage vs C.S. Threshold

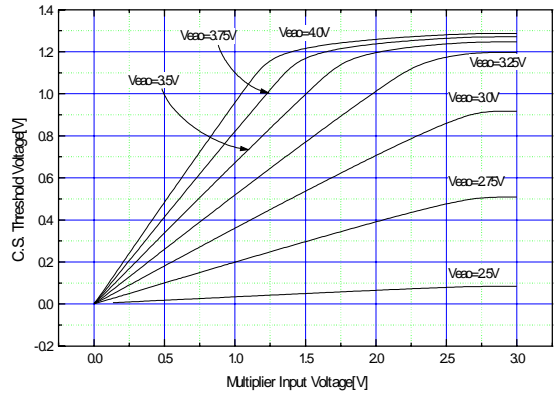

Figure 2. Multiplier Input Voltage vs C.S. Threshold

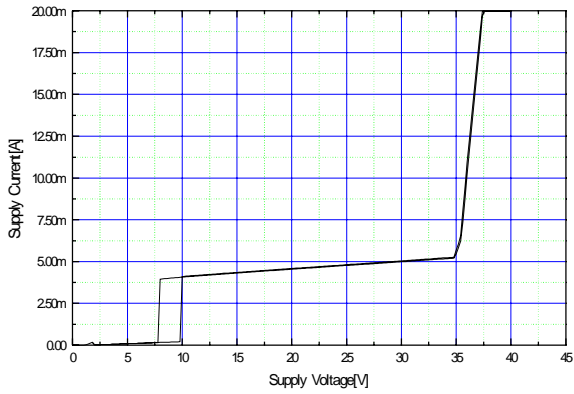

Figure 3. Supply Current vs Supply Voltage

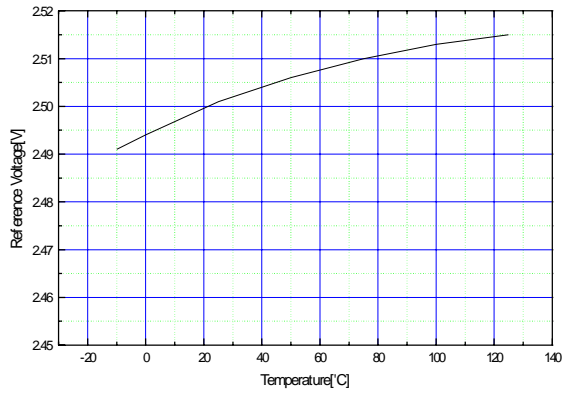

Figure 4. Reference Voltage vs Temperature

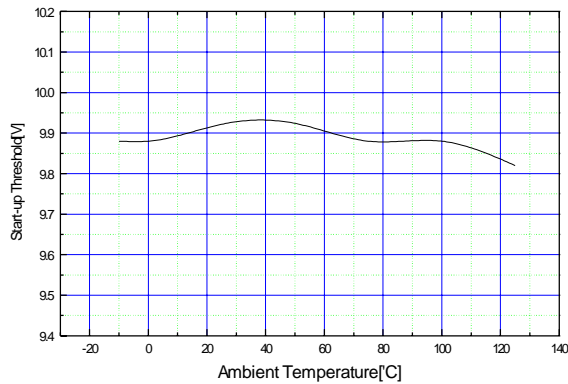

Figure 5. Start-up Threshold vs Temperature

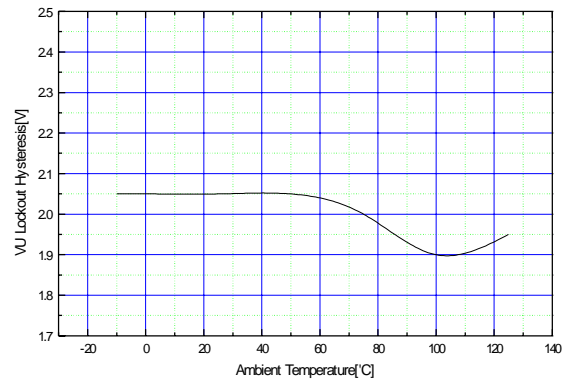

Figure 6. UV Lockout Hysteresis vs Temperature

Typical Performance Characteristics (Continued)

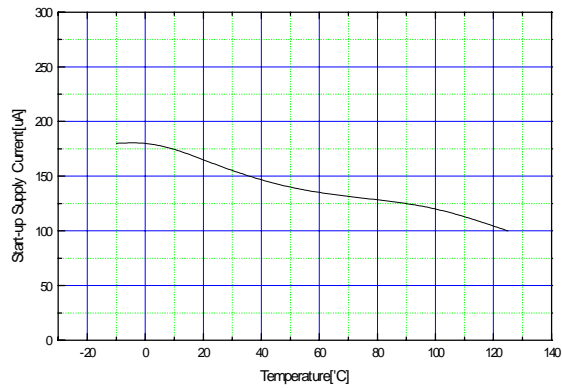

Figure 7. Start-up Supply Current vs Temperature

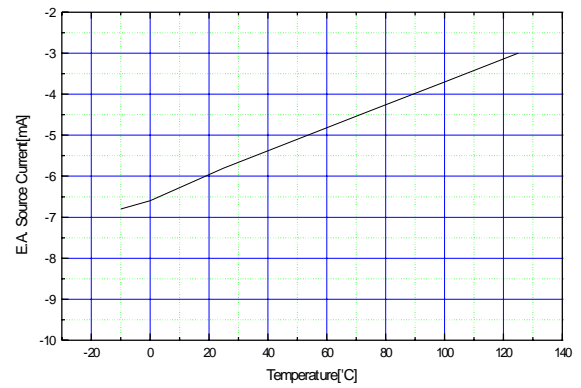

Figure 8. E.A. Source Current vs Temperature

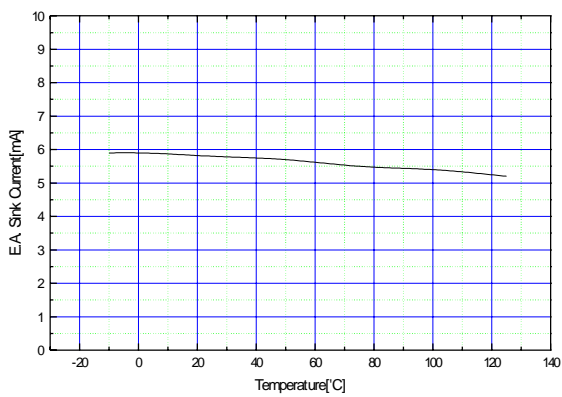

Figure 9. E.A. Sink Current vs Temperature

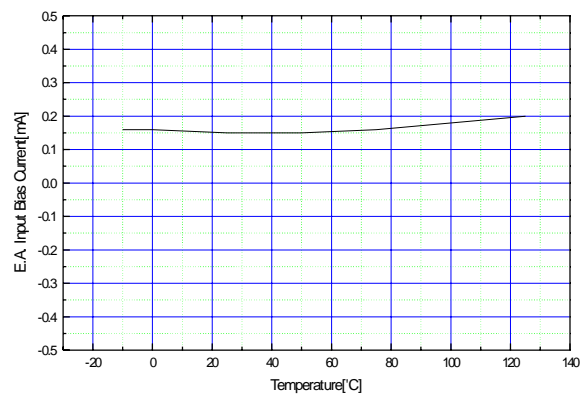

Figure 10. E.A. Input Bias Current vs Temperature

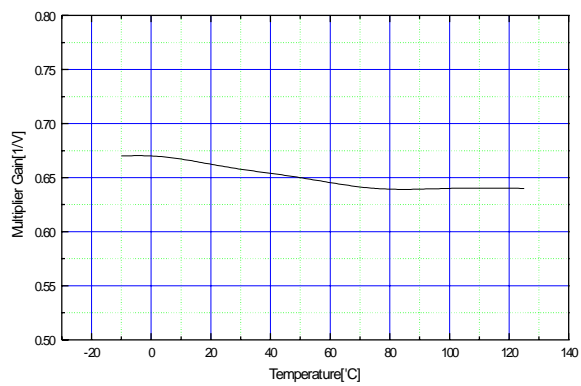

Figure 11. Multiplier Gain vs Temperature

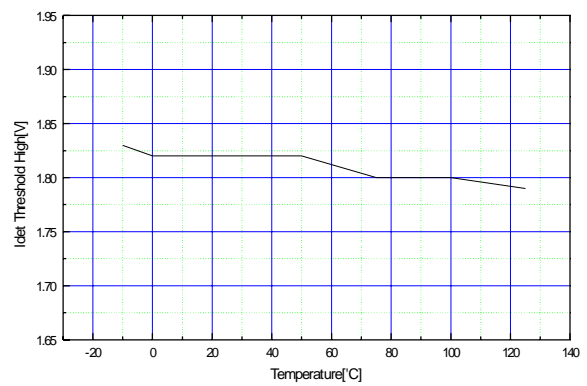

Figure 12. Idet Threshold High vs Temperature

Typical Performance Characteristics (Continued)

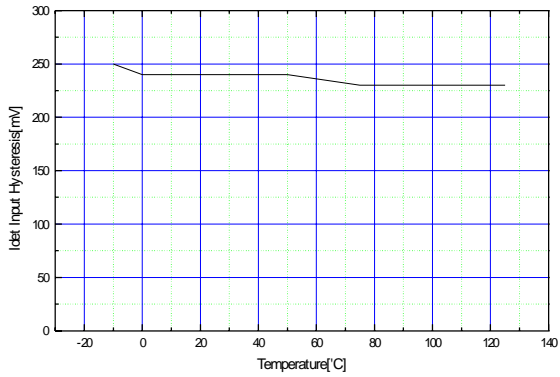

Figure 13. Idet Input Hysteresis vs Temperature

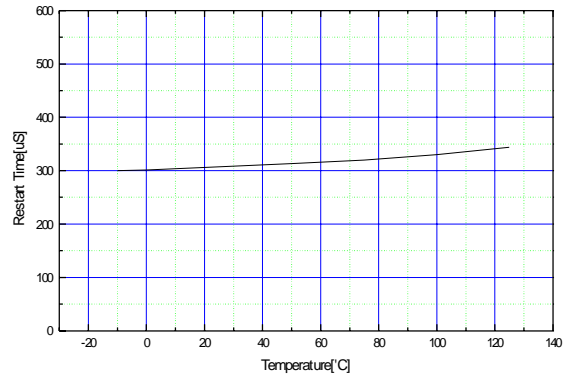

Figure 14. Restart Time vs Temperature

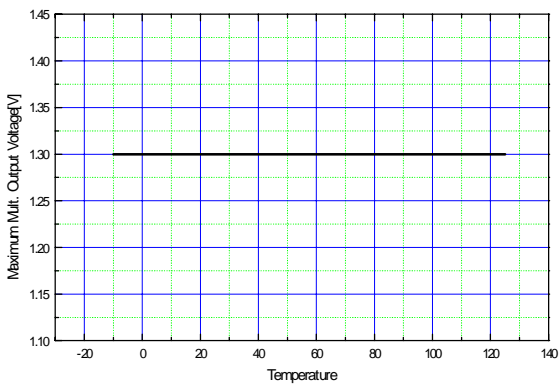

Figure 15. Max. Mult. Output Voltage vs Temperature

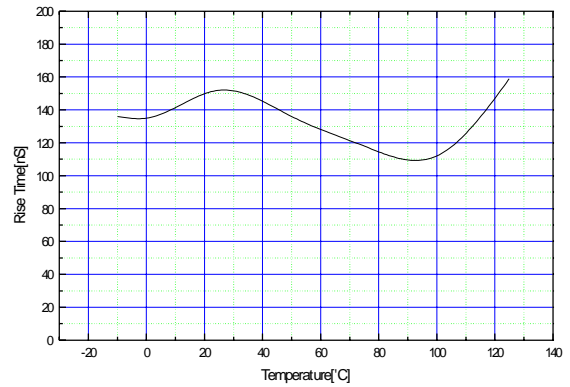

Figure 16. Rise Time vs Temperature

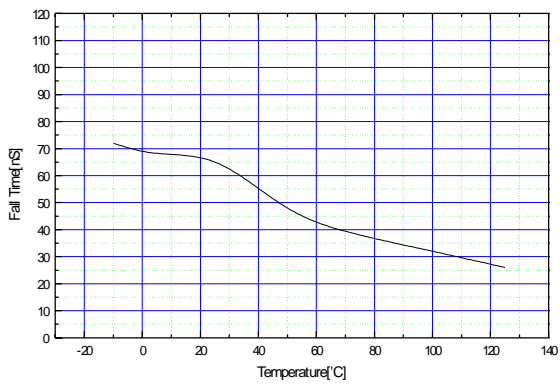

Figure 17. Fall Time vs Temperature

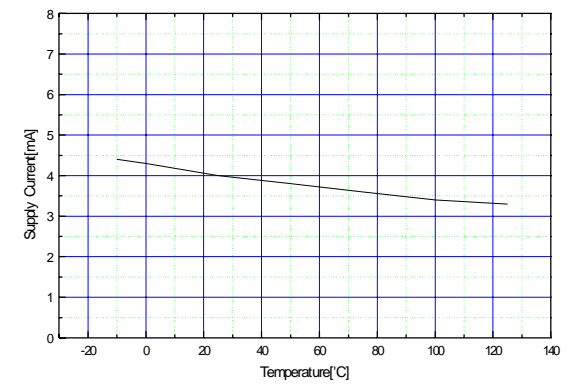

Figure 18. Supply Current vs Temperature

Operating Description

KA7525B is high performance, critical conduction, current-mode power factor controller specifically designed for use in off line active preconverters with minimal external components. This device provides the necessary features required to significantly enhance poor power factor loads by keeping the ac line current sinusoidal and in phase with the line voltage.

KA7525B contains many of the building blocks and protection features that are employed in modern high performance current mode power supply controllers. A description of each of the function blocks is given below.

START-UP

An Under Voltage Lockout comparator has been incorporated to guarantee that IC is fully functional before enable the output stage. The positive power supply terminal (Vcc) is monitored by the UVLO comparator with the upper threshold set at 10V and the lower threshold at 7.9V. In the stand-by mode, with Vcc at 9.5V, the required supply current is less than 0.2mA. This large hysteresis and low start-up current allow the implementation of efficient bootstrap start-up techniques, making this device ideally suited for wide range off-line preconverter applications.

Fig.1.1 shows the start-up circuit. Circuit operation is as follows:

The start-up capacitor (Cst) is charged by current through start-up resistor (Rst) minus the start-up current drawn by the IC. Once the capacitor voltage reaches the start-up threshold, the IC turns on, starting the switching of the MOSFET. The operation of the IC demands an increase in operating current which results in discharging the capacitor. Before the start-up capacitor voltage is discharged below hysteresis voltage, the auxiliary winding voltage takes over as the supply voltage as shown in Fig. 1.2.

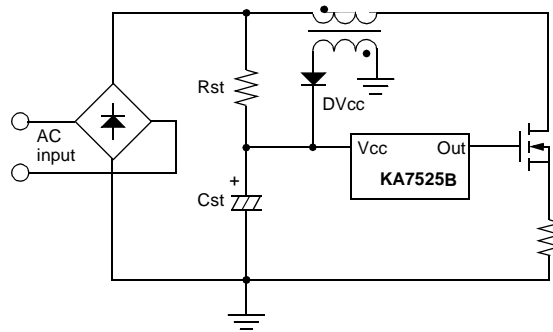

Figure 1.1 Start-up Circuit

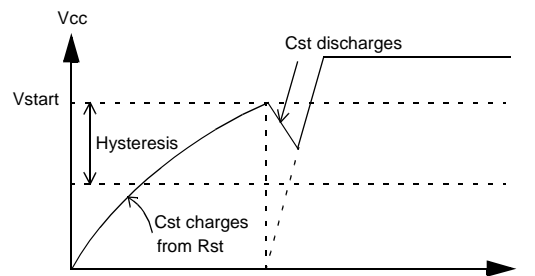

Figure 1.2 Start-up Capacitor Voltage

Error Amplifier

An Error Amplifier with access to the inverting input and output is provided. The noninverting input is internally biased at 2.5V and is not pinned out. The output voltage of the power factor converter is typically divided down and monitored by the inverting input. The error amp output is internally connected to the multiplier and is pinned out for external loop compensation. Typically, the bandwidth is set below 20Hz, so that the amplifier's output voltage is relatively constant over a given ac line cycle. In effect, the error amp monitors the average output voltage of the converter over several line cycles. Input bias current (0.5uA, max) can cause an output voltage error that is equal to the product of the input bias current and the value of the upper divider resistor, R1 in Fig. 2.1.

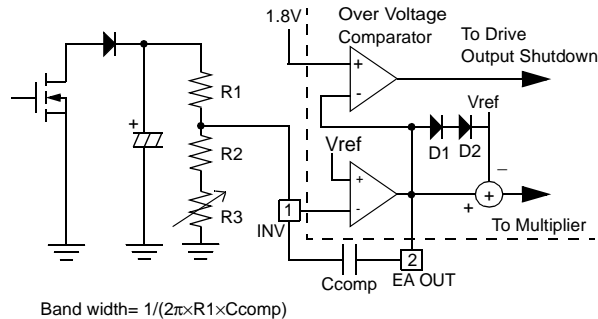

Figure 2.1 Error Amp and Over Voltage Comparator

Over Voltage Protection

The low bandwidth (typically below 20Hz) characteristic of Error Amplifier control loop results in output voltage runaway condition. This condition can occur during initial start-up, sudden load removal, or during output arcing. The over voltage comparator monitors the output voltage of the error amplifier. When load is removed, error amp output swings lower than 1.8V, comparator is triggered high and output driver is turned off till the error amp inverting input voltage drops below 2.5V. At this point, the error amp output swings positive, turns the output driver back on. The diode, D1, D2 clamp the error amp output voltage to two diode drops above reference voltage. This prohibits the error amplifier from being saturated, allowing it to recover faster thus minimizing the boost voltage overshoot.

Multiplier

A single quadrant, two input multiplier is the critical element that enables this device to get power factor correction. One input of multiplier (Pin 3) is connected to an external resistor divider monitoring the rectified ac line. The other input is internally driven by a DC voltage which is the difference of error amplifier output (Pin 2) and reference voltage, Vref. The multiplier is designed to have an extremely linear transfer curve over a wide dynamic range, 0V to 2V for Pin 3, and 2.5V to 3.5V for the error amplifier output under all line and load conditions.

The multiplier output controls the current sense comparator threshold as the ac voltage traverses sinusoidally from zero to peak line. This allows the inductor peak current to follow the ac line thus forcing the average input current to be sinusoidal. In other words, this has the effect of forcing the MOSFET on-time to track the input line voltage, resulting in a fixed drive output on-time, thus making the preconverter load appear to be resistive to the ac line.

The equation below describes the relationship between multiplier output and inputs.

$$V_{mo} = K \times V_{m1} \times (V_{m2} - V_{ref})$$

K : Multiplier gain

V_{m1} : Voltage at Pin 3

V_{m2} : Error amp output voltage

V_{mo} : Multiplier output voltage

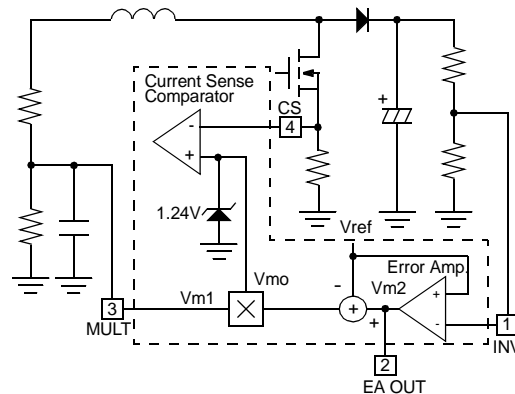

Figure 3.1 Multiplier Block

Current Sense Comparator

The current sense comparator RS latch configuration used ensures that only a single pulse appears at the drive output during a given cycle. MOSFET drain current is converted to voltage using an external sense resistor in series with the external power MOSFET. When sense voltage exceeds the threshold set by the multiplier output, the current sense comparator terminates the gate drive to the MOSFET and resets the PWM latch. The latch insures that the output remains in a low state after the MOSFET drain current falls back to zero.

The peak inductor current under normal operating conditions is controlled by the multiplier output, V_{mo} .

Abnormal operating conditions occur during preconverter start-up at extremely high line or if output voltage sensing is lost.

Under these conditions, the multiplier output and current sense threshold will be internally clamped to 1.24V. Therefore, the maximum peak switch current is limited to:

$$I_{pk(max)} = 1.24V / R_{sense}$$

Internal R,C filter has been included to attenuate any high frequency noise that may be present on the current waveform. These circuit block eliminate the need for an external RC filter otherwise required for proper operation of the circuit.

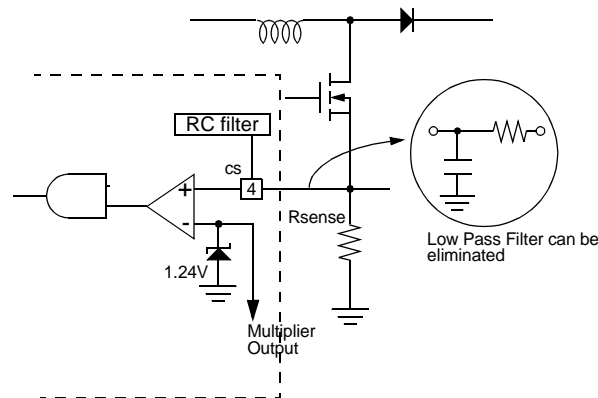

Figure 4.1 Current Sense Circuit

Zero Current Detector

KA7525B operates as a critical conduction current mode controller. The power MOSFET is turned on by the zero current detector and turned off when the peak inductor current reaches the threshold level established by the multiplier output. The slope of the inductor current is indirectly detected by monitoring the voltage across a separate winding and connecting it to the zero current detector Pin 5.

Once the inductor current reaches ground level, the voltage across the winding reverses polarity. When the Idet input falls below 1.8V, the comparator output is triggered to the low state.

To prevent false tripping, 240mV of hysteresis is provided. The zero current detector input is internally protected by two clamps.

The upper 7.5V clamp prevents input over voltage breakdown while the lower 0.75V clamp prevents substrate injection. An internal current limit resistor protects the lower clamp transistor in case the Idet pin is accidentally shorted to ground.

A watchdog timer function was added to the IC to eliminate the need for an external oscillator when used in stand-alone applications. The timer provides a means to automatically start or restart the preconverter if the drive output has been off for more than 300us after the inductor current reaches zero.

Drive Output

The KA7525B contains a single totem-pole output stage specifically designed for direct drive of power MOSFET. The drive output is capable of up to 500mA peak current with a typical rise and fall time of 130ns, 50ns each with a 1.0nF load.

Additional internal circuitry has been added to keep the drive output in a sinking mode whenever the UVLO is active. This characteristic eliminates the need for an external gate pull-down resistor. Internal voltage clamping ensures that output driver is always lower than 13V when supply voltage variation exceeds more than rated Vgs threshold (typ 20V) of the external MOSFET. This eliminates an external zener diode and extra power dissipation associated with it that otherwise is required for reliable circuit operation.

Application Circuit(#1)

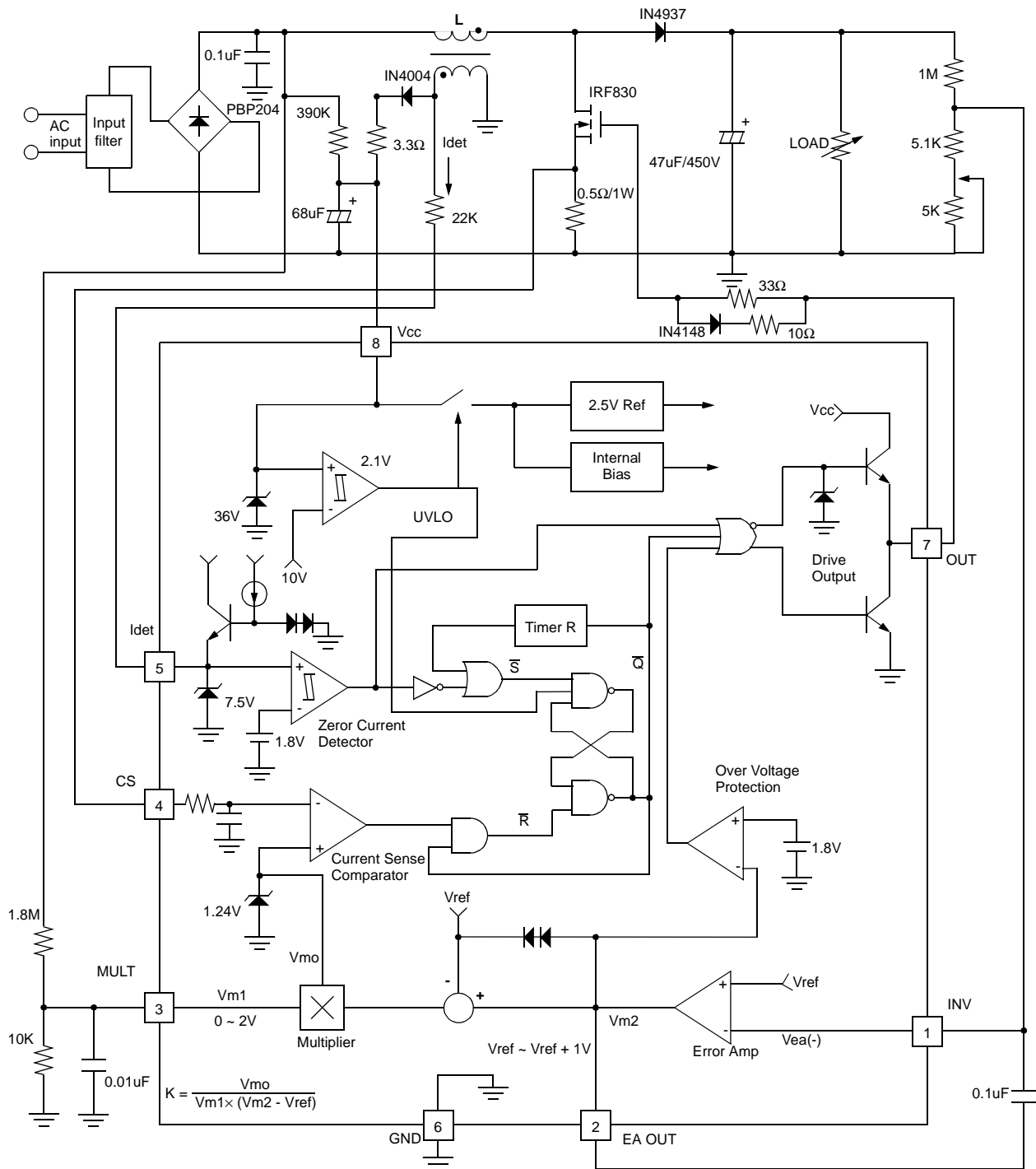

Application Circuit(#2)

< 32W×2 Lamps Self-oscillating Ballast >

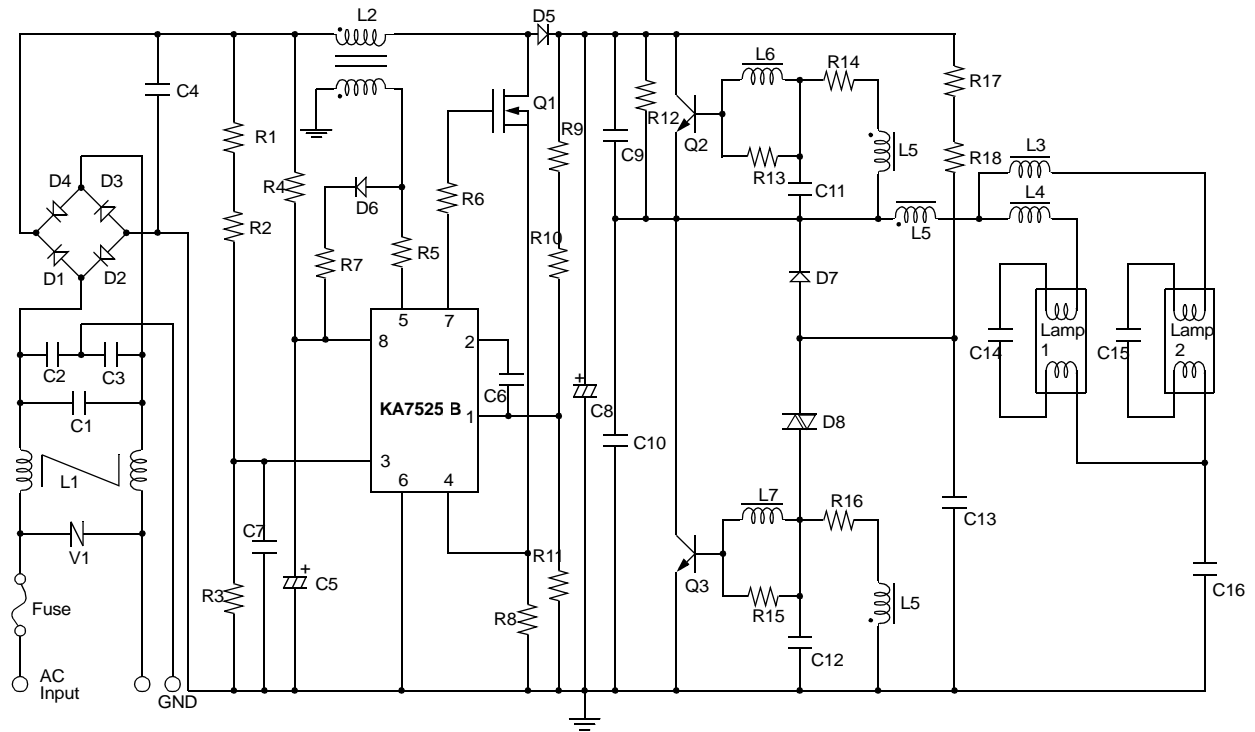

Component Listing

(For Application #2)

| Reference | Value | Part Number | Manufacturer |
|------------|------------------------|-------------|--------------|
| R1, 2 | 1.1M Ω -F, 1/4W | 26mm Type | - |
| R3 | 11k Ω -F, 1/4W | 26mm Type | - |
| R4 | 130k Ω , 1/2W | 26mm Type | - |
| R5 | 22k Ω -J, 1/4W | 26mm Type | - |
| R6, 13, 15 | 47k Ω -J, 1/4W | 26mm Type | - |
| R7 | 3.3 Ω , 1/4W | 26mm Type | - |
| R8 | 1 Ω -J, 1W | 26mm Type | - |
| R9 | 180k Ω -F, 1/4W | 26mm Type | - |
| R10 | 820k Ω -F, 1/4W | 26mm Type | - |
| R11 | 6.8k Ω -F, 1/4W | 26mm Type | - |

Component Listing (Continued)

| Reference | Value | Part Number | Manufacturer |
|----------------|------------------------------|--------------|--------------|
| R12, 17, 18 | 390k Ω -J, 1/4W | 26mm Type | - |
| R14, 16 | 8.2 Ω -J, 1/4W | 26mm Type | - |
| C1 | 0.15 μ F, 630V | MEP-CAP | - |
| C2, 3 | 2200pF, 3000V | Y-CAP | - |
| C4 | 0.22 μ F, 630V | MPE-CAP | - |
| C5 | 22 μ F, 35V | Electrolytic | - |
| C6 | 0.22 μ F, 25V | PPF-CAP | - |
| C7 | 1000pF, 50V | PPF-CAP | - |
| C8 | 47 μ F, 450V | Electrolytic | - |
| C9 | 4700pF, 630V | PPF-CAP | - |
| C10 | 2200pF, 630V | PPF-CAP | - |
| C11, 12 | 0.15 μ F, 630V | MPF-CAP | - |
| C13 | 0.1 μ F, 50V | PPF-CAP | - |
| C14, 15 | 8200pF, 1000V | PP-CAP | - |
| C16 | 0.15 μ F, 630V | MEP-CAP | - |
| D1, 2, 3, 4, 7 | 1000V, 1A | IN4007GP | - |
| D5 | 1000V, 1.5A | BYV26C | - |
| D6 | 75V, 150mA | IN4148 | - |
| D8 | - | N413N (DIAC) | - |
| L1 | DR 10 \times 12 | DIT-010 | - |
| L2 | EI 2519 | DBT-002 | - |
| L3, 4 | EI 2820 | DPT-086 | - |
| L5 | SB5S 8 \times 3 \times 4 | DDT-005 | - |
| L6, 7 | 10 μ H | BS24-100K | - |
| Fuse | - | 52NM250V, 3A | - |
| V1 | 430V | INR140, 431 | - |
| KA7525B | - | KA7525B | FairChild |
| Q1 | 500V, 4.5A | FQPF6N50 | FairChild |
| Q2, 3 | 400V, 5A | KSC5305D | FairChild |

Mechanical Dimensions

Package

Dimensions in millimeters

8-DIP

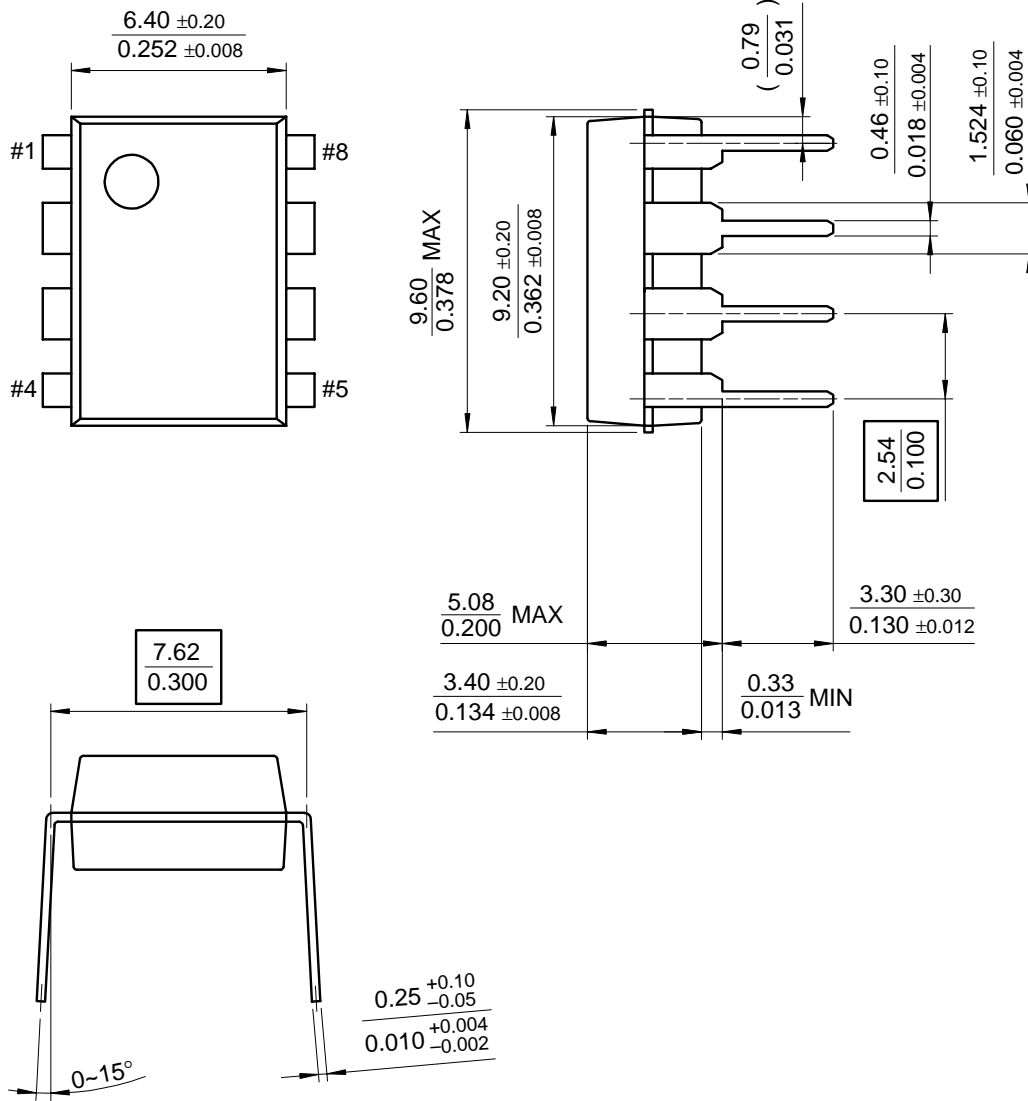

Mechanical Dimensions (Continued)

Package

Dimensions in millimeters

8-SOP

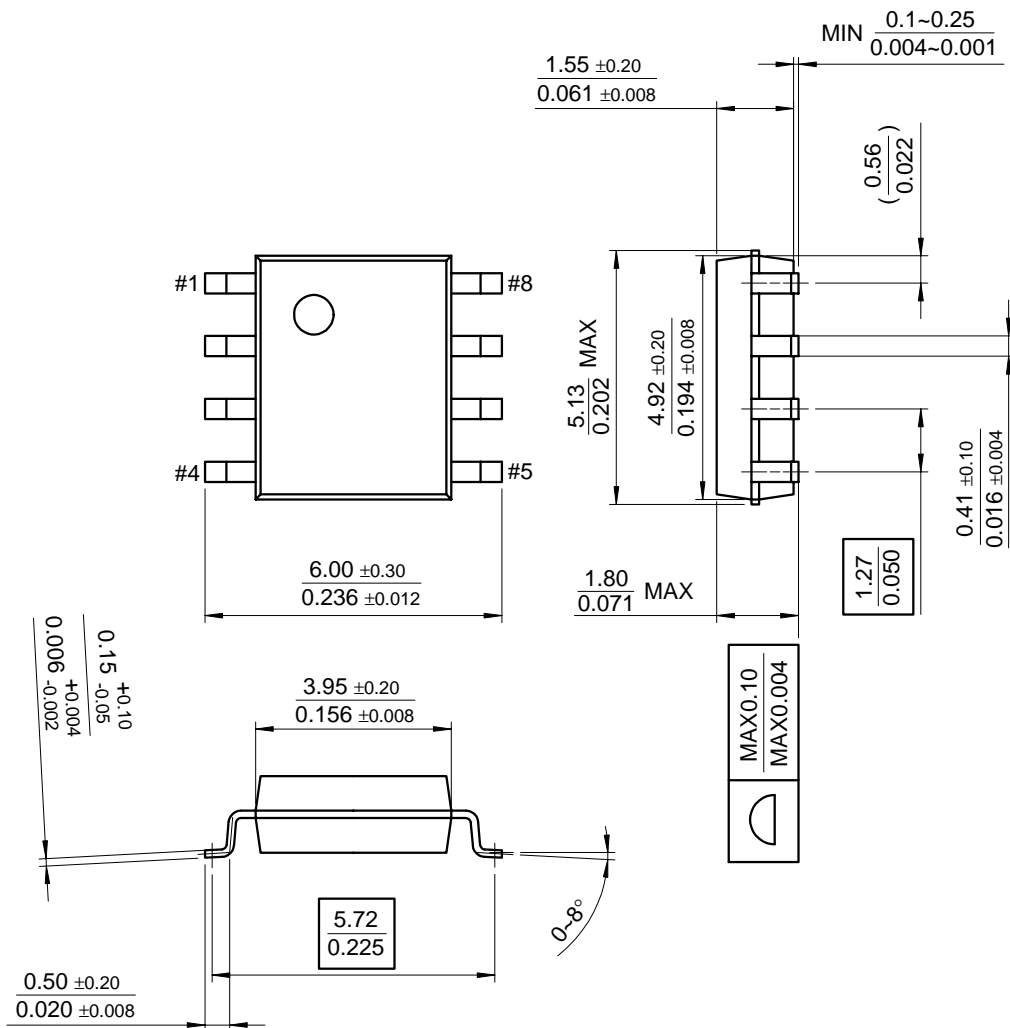

Ordering Information

| Product Number | Package | Operating Temperature |
|----------------|---------|-----------------------|
| KA7525B | 8-DIP | 0 ~ +125°C |
| KA7525BD | 8-SOP | |

DISCLAIMER

FAIRCHILD SEMICONDUCTOR RESERVES THE RIGHT TO MAKE CHANGES WITHOUT FURTHER NOTICE TO ANY PRODUCTS HEREIN TO IMPROVE RELIABILITY, FUNCTION OR DESIGN. FAIRCHILD DOES NOT ASSUME ANY LIABILITY ARISING OUT OF THE APPLICATION OR USE OF ANY PRODUCT OR CIRCUIT DESCRIBED HEREIN; NEITHER DOES IT CONVEY ANY LICENSE UNDER ITS PATENT RIGHTS, NOR THE RIGHTS OF OTHERS.

LIFE SUPPORT POLICY

FAIRCHILD'S PRODUCTS ARE NOT AUTHORIZED FOR USE AS CRITICAL COMPONENTS IN LIFE SUPPORT DEVICES OR SYSTEMS WITHOUT THE EXPRESS WRITTEN APPROVAL OF THE PRESIDENT OF FAIRCHILD SEMICONDUCTOR CORPORATION. As used herein:

1. Life support devices or systems are devices or systems which, (a) are intended for surgical implant into the body, or (b) support or sustain life, and (c) whose failure to perform when properly used in accordance with instructions for use provided in the labeling, can be reasonably expected to result in a significant injury of the user.
2. A critical component in any component of a life support device or system whose failure to perform can be reasonably expected to cause the failure of the life support device or system, or to affect its safety or effectiveness.