



SURFACE MOUNT LED LAMP

STANDARD BRIGHT 1206

QTLP650C-2 / QTLP650D-2 HER

QTLP650C-3 / QTLP650D-3 Yellow

QTLP650C-4 / QTLP650D-4 Green

QTLP650C-7 / QTLP650D-7 AlGaAs Red

QTLP650C-B Blue

PACKAGE DIMENSIONS

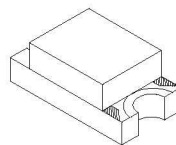
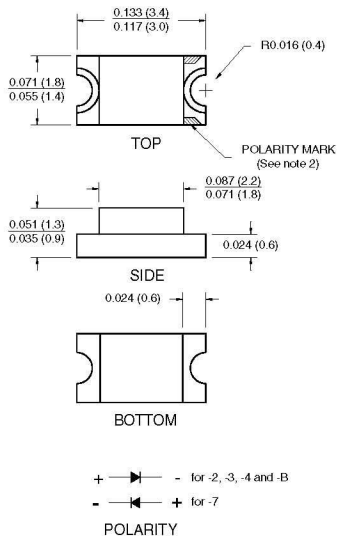

NOTE:

1. Dimensions for all drawings are in inches (mm).
2. Cathode for -2, -3, -4 and B. Anode for -7.

APPLICATIONS

- Keypad backlighting
- Push-button backlighting
- LCD backlighting

DESCRIPTION

These surface mount chip LEDs are designed to fit industry standard footprint. Low profile and wide viewing angle make these LEDs ideal choices for backlighting applications and panel illumination.

FEATURES

- Small footprint - 3.2(L) X 1.6(W) X 1.1(H) mm
- Wide viewing angle of 140°(QTLP650C) or 160°(QTLP650D)
- Water clear (QTLP650C) or diffused (QTLP650D) optics
- Moisture-proof packaging
- Available in 0.315" (8mm) width tape on 7" (178mm) diameter reel; 2,000 units per reel



SURFACE MOUNT LED LAMP

STANDARD BRIGHT 1206

QTLP650C-2 / QTLP650D-2 HER

QTLP650C-3 / QTLP650D-3 Yellow

QTLP650C-4 / QTLP650D-4 Green

QTLP650C-7 / QTLP650D-7 AlGaAs Red

QTLP650C-B Blue

ABSOLUTE MAXIMUM RATINGS (T_A = 25°C Unless otherwise specified)

Parameter	Symbol	QTLP650C / QTLP650D					Units
		-2	-3	-4	-7	-B*	
Continuous Forward Current	I _F	30	30	30	30	30	mA
Peak Forward Current (f = 1.0 KHZ, Duty Factor = 1/10)	I _{FM}	160	160	160	180	100	mA
Reverse Voltage (I _R = 10 μA)	V _R	5	5	5	5	5	V
Power Dissipation	P _D	84	84	84	72	135	mW
Operating Temperature	T _{OPR}	-40 to +85					°C
Storage Temperature	T _{STG}	-40 to +90					°C
Lead Soldering Time	T _{SOL}	260 for 5 sec					°C

ELECTRICAL / OPTICAL CHARACTERISTICS (T_A = 25°C)

Part Number	Symbol	QTLP650C / QTLP650D					Condition
		-2	-3	-4	-7	-B*	
Luminous Intensity (mcd) Minimum	I _V	4 / 3	4 / 3	6 / 5	10 / 8	10 / -	I _F = 20mA
		10 / 8	10 / 8	10 / 8	20 / 15	20 / -	
Forward Voltage (V) Maximum	V _F	2.8	2.8	2.8	2.4	4.5	I _F = 20mA
		2.0	2.0	2.1	1.9	3.8	
Wavelength (nm) Peak	λ _P	635	585	565	660	430	I _F = 20mA
		630	590	570	645	465	
Spectral Line Half Width (nm)	Δλ	45	35	30	20	65	I _F = 20mA
Viewing Angle (°)	2θ _{1/2}	140 / 160	140 / 160	140 / 160	140 / 160	140 / -	I _F = 20mA

* Available only in QTLP650C



SURFACE MOUNT LED LAMP

STANDARD BRIGHT 1206

QTLP650C-2 / QTLP650D-2 HER

QTLP650C-3 / QTLP650D-3 Yellow

QTLP650C-4 / QTLP650D-4 Green

QTLP650C-7 / QTLP650D-7 AlGaAs Red

QTLP650C-B Blue

TYPICAL PERFORMANCE CURVES

Fig. 1 Forward Current vs. Forward Voltage

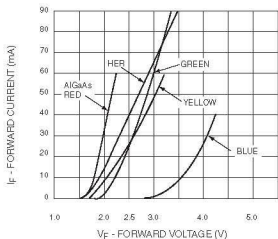

Fig. 2 Relative Luminous Intensity vs. DC Forward Current

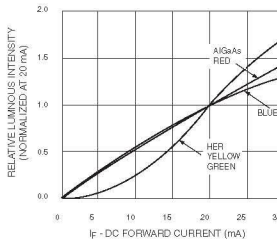

Fig. 3 Relative Intensity vs. Peak Wavelength

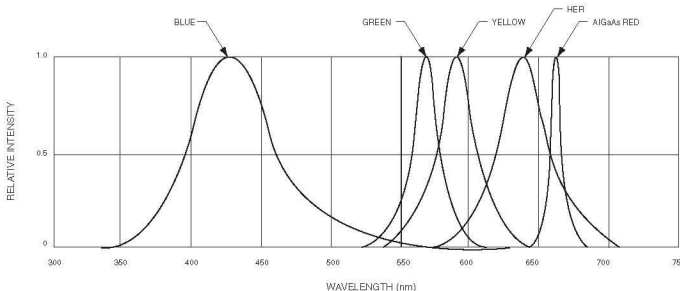

Fig. 4 Radiation Diagram

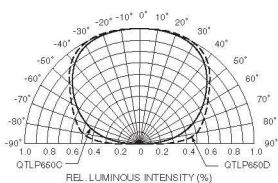
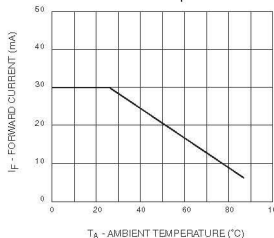

Fig. 5 Maximum Forward Current vs. Ambient Temperature





SURFACE MOUNT LED LAMP

STANDARD BRIGHT 1206

QTLP650C-2 / QTLP650D-2 HER

QTLP650C-3 / QTLP650D-3 Yellow

QTLP650C-4 / QTLP650D-4 Green

QTLP650C-7 / QTLP650D-7 AlGaAs Red

QTLP650C-B Blue

RECOMMENDED PRINTED CIRCUIT BOARD PATTERN

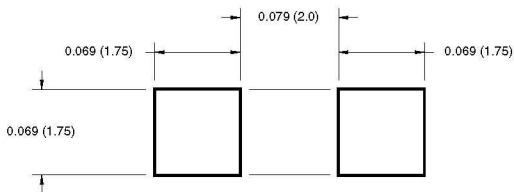

RECOMMENDED IR REFLOW SOLDERING PROFILE

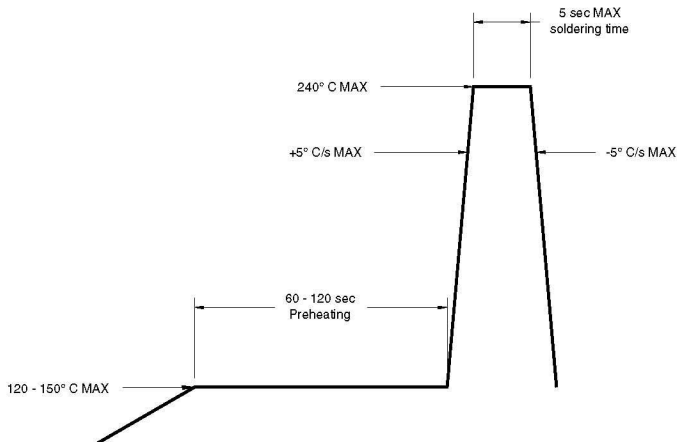



SURFACE MOUNT LED LAMP

STANDARD BRIGHT 1206

QTLP650C-2 / QTLP650D-2 HER

QTLP650C-3 / QTLP650D-3 Yellow

QTLP650C-4 / QTLP650D-4 Green

QTLP650C-7 / QTLP650D-7 AlGaAs Red

QTLP650C-B Blue

TAPE AND REEL DIMENSIONS

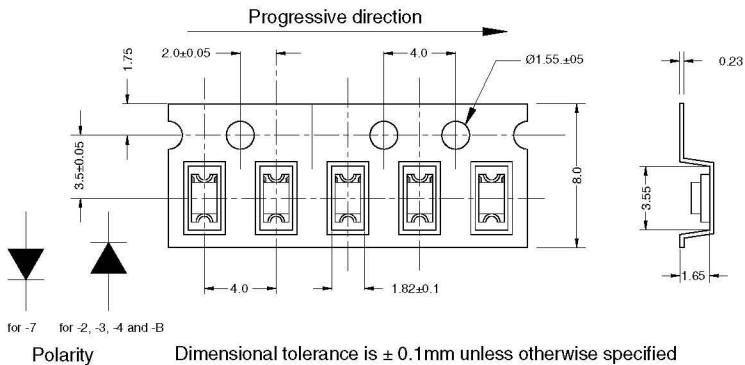
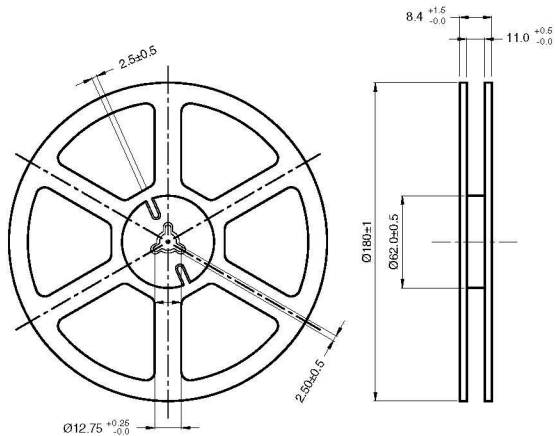

for -7 for -2, -3, -4 and -B

Polarity

Dimensional tolerance is ± 0.1 mm unless otherwise specified

Angle: ± 0.5

Unit: mm



SURFACE MOUNT LED LAMP

STANDARD BRIGHT 1206

QTLP650C-2 / QTLP650D-2 HER

QTLP650C-3 / QTLP650D-3 Yellow

QTLP650C-4 / QTLP650D-4 Green

QTLP650C-7 / QTLP650D-7 AlGaAs Red

QTLP650C-B Blue

DISCLAIMER

FAIRCHILD SEMICONDUCTOR RESERVES THE RIGHT TO MAKE CHANGES WITHOUT FURTHER NOTICE TO ANY PRODUCTS HEREIN TO IMPROVE RELIABILITY, FUNCTION OR DESIGN. FAIRCHILD DOES NOT ASSUME ANY LIABILITY ARISING OUT OF THE APPLICATION OR USE OF ANY PRODUCT OR CIRCUIT DESCRIBED HEREIN; NEITHER DOES IT CONVEY ANY LICENSE UNDER ITS PATENT RIGHTS, NOR THE RIGHTS OF OTHERS.

LIFE SUPPORT POLICY

FAIRCHILD'S PRODUCTS ARE NOT AUTHORIZED FOR USE AS CRITICAL COMPONENTS IN LIFE SUPPORT DEVICES OR SYSTEMS WITHOUT THE EXPRESS WRITTEN APPROVAL OF THE PRESIDENT OF FAIRCHILD SEMICONDUCTOR CORPORATION. As used herein:

1. Life support devices or systems are devices or systems which, (a) are intended for surgical implant into the body, or (b) support or sustain life, and (c) whose failure to perform when properly used in accordance with instructions for use provided in labeling, can be reasonably expected to result in a significant injury of the user.
2. A critical component in any component of a life support device or system whose failure to perform can be reasonably expected to cause the failure of the life support device or system, or to affect its safety or effectiveness.