

**PRELIMINARY**  
 Notice: This is not a final specification.  
 Some parametric limits are subject to change.

**MITSUBISHI ASTTLs**  
**M74AS832BP**

T-43-15

**HEX 2-INPUT OR DRIVER**  
 91D 12257 D

6249827 MITSUBISHI (DGTL LOGIC)

**DESCRIPTION**

The M74AS832BP is a semiconductor integrated circuit consisting of six 2-input positive-logic OR buffer gates, usable as negative-logic AND buffer gates.

**FEATURES**

- High fan-out ( $I_{OL}=48\text{mA}$ ,  $I_{OH}=-48\text{mA}$ )
- High speed
- Wide operating temperature range ( $T_a=-20\sim+75^\circ\text{C}$ )
- High package density with six circuits in one package

**APPLICATION**

General purpose, for use in industrial and consumer digital equipment.

**FUNCTIONAL DESCRIPTION**

Employing PNP transistors in the inputs and active pullup in the outputs, the M74AS832BP achieves high speed and high fan-out. To reduce problems in high-speed switching, it has Miller-killer circuit and clamp diodes (both input and output).

When both A and B inputs are low-level, output Y is low-level, and when at least one of the inputs is high, the output is high. This device has the same function as M74AS1832P with different pin connections.

**PIN CONFIGURATION (TOP VIEW)**

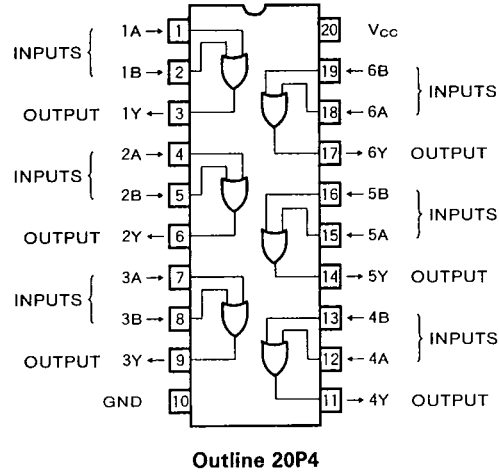

**FUNCTION TABLE**

Inputs		Output
A	B	Y
L	L	L
H	L	H
L	H	H
H	H	H

**CIRCUIT SCHEMATIC (EACH BUFFER)**

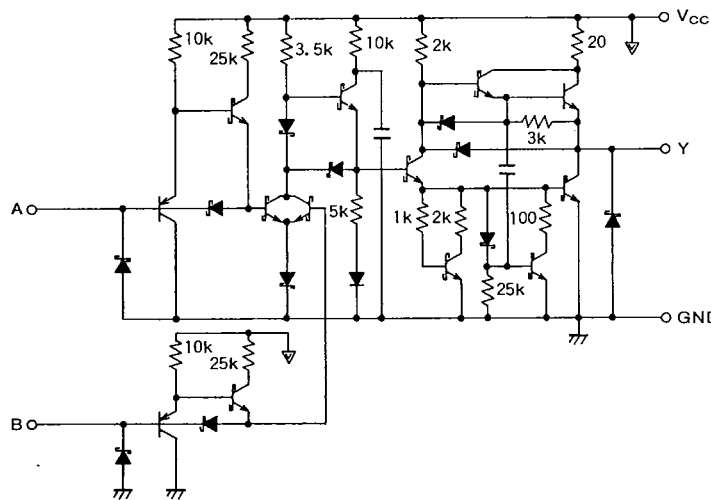

UNIT :  $\Omega$

MITSUBISHI ASTTLs  
**M74AS832BP**

6249827 MITSUBISHI (DGTL LOGIC)

91D 12258 DT-43-15  
**HEX 2-INPUT OR DRIVER**

**ABSOLUTE MAXIMUM RATINGS** ( $T_a = -20 \sim +75^\circ\text{C}$ , unless otherwise noted)

Symbol	Parameter	Conditions	Ratings	Unit
$V_{CC}$	Supply voltage		-0.5~+7	V
$V_I$	Input voltage		-0.5~+7	V
$V_O$	Output voltage	High-level state	-0.5~ $V_{CC}$	V
$T_{opr}$	Operating free-air ambient temperature range		-20~+75	$^\circ\text{C}$
$T_{stg}$	Storage temperature range		-65~+150	$^\circ\text{C}$

**RECOMMENDED OPERATING CONDITIONS**

Symbol	Parameter	Limits			Unit
		Min	Typ	Max	
$V_{CC}$	Supply voltage	4.5	5	5.5	V
$V_{IH}$	High-level input voltage	2			V
$V_{IL}$	Low-level input voltage			0.8	V
$I_{OH}$	High-level output current	0		-48	mA
$I_{OL}$	Low-level output current	0		48	mA
$T_{opr}$	Operating free-air ambient temperature range	-20		+75	$^\circ\text{C}$

**ELECTRICAL CHARACTERISTICS** ( $T_a = -20 \sim +75^\circ\text{C}$ , unless otherwise noted)

Symbol	Parameter	Test conditions	Limits			Unit
			Min	Typ*	Max	
$V_{IC}$	Input clamp voltage	$V_{CC}=4.5\text{V}, I_{IC}=-18\text{mA}$			-1.2	V
$V_{OH}$	High-level output voltage	$V_{CC}=4.5\text{V} \sim 5.5\text{V}, I_{OH}=-2\text{mA}$	$V_{CC}-2$			V
		$V_{CC}=4.5\text{V}$	2.4	3.2		
$V_{OL}$	Low-level output voltage	$V_{CC}=4.5\text{V}, I_{OL}=48\text{mA}$			0.5	V
$I_I$	Input current at maximum voltage	$V_{CC}=5.5\text{V}, V_I=7\text{V}$			0.1	mA
$I_{IH}$	High-level input current	$V_{CC}=5.5\text{V}, V_I=2.7\text{V}$			20	$\mu\text{A}$
$I_{IL}$	Low-level input current	$V_{CC}=5.5\text{V}, V_I=0.4\text{V}$			-0.5	mA
$I_O$	Output current	$V_{CC}=5.5\text{V}, V_O=2.25\text{V}$	-50		-200	mA
$I_{CCH}$	Supply current, all outputs high	$V_{CC}=5.5\text{V}, V_I=4.5\text{V}$		11	17	mA
$I_{CCL}$	Supply current, all outputs low	$V_{CC}=5.5\text{V}, V_I=0\text{V}$		22	36	mA

\*: All typical values are at  $V_{CC}=5\text{V}, T_a=25^\circ\text{C}$ .

MITSUBISHI ASTTLs  
**M74AS832BP**

6249827 MITSUBISHI (DGTL LOGIC)

91D 12259 DT-43-15

**HEX 2-INPUT OR DRIVER**

**SWITCHING CHARACTERISTICS**

Symbol	Parameter	Test conditions/Limits							Unit	
		V <sub>CC</sub> =4.5~5.5V (Note 1) C <sub>L</sub> =50pF R <sub>L</sub> =500Ω								
		T <sub>a</sub> =0~70°C			T <sub>a</sub> =-20~+75°C					
		Inputs	Output	Min	Typ*	Max	Min	Typ*	Max	
t <sub>PLH</sub>	Propagation time	A, B	Y	1		6.3	1		7	ns
t <sub>PHL</sub>				1		6.3	1		7	

\*: All typical values are at V<sub>CC</sub>=5V, T<sub>a</sub>=25°C.

Note 1: Measurement circuit

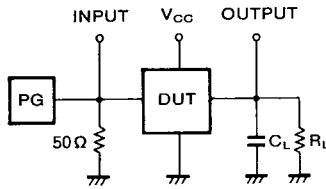

**TIMING DIAGRAM (Reference level=1.3V)**

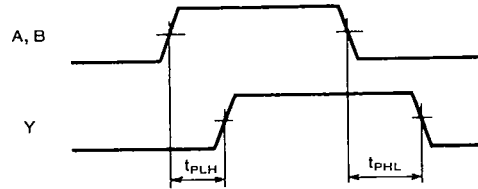

(1) The pulse generator (PG) has the following characteristics:

- PRR ≤ 1MHz
- t<sub>r</sub> = 2ns, t<sub>f</sub> = 2ns
- V<sub>IH</sub> = 3.5V, V<sub>IL</sub> = 0.3V
- duty cycle = 50%
- Z<sub>o</sub> = 50Ω

(2) C<sub>L</sub> includes probe and jig capacitance.

T-90-20

TYPE 14P4 14-PIN MOLDED PLASTIC DIP

Dimension in mm

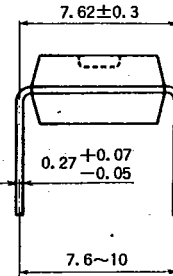
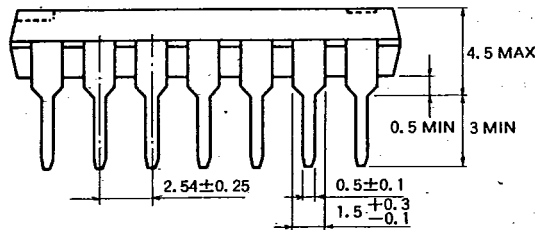
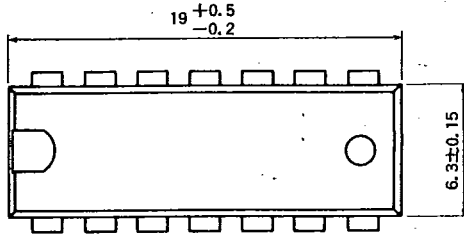

TYPE 16P4 16-PIN MOLDED PLASTIC DIP

Dimension in mm

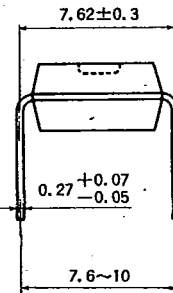
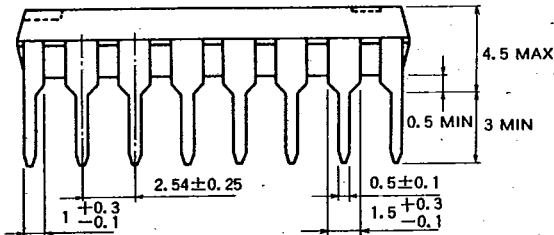
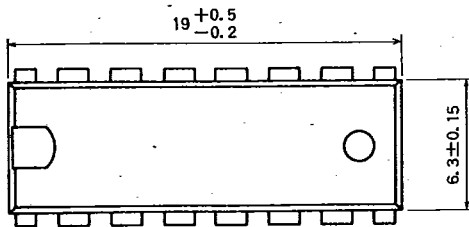

T-90-20

**TYPE 20P4 20-PIN MOLDED PLASTIC DIP**

Dimension in mm

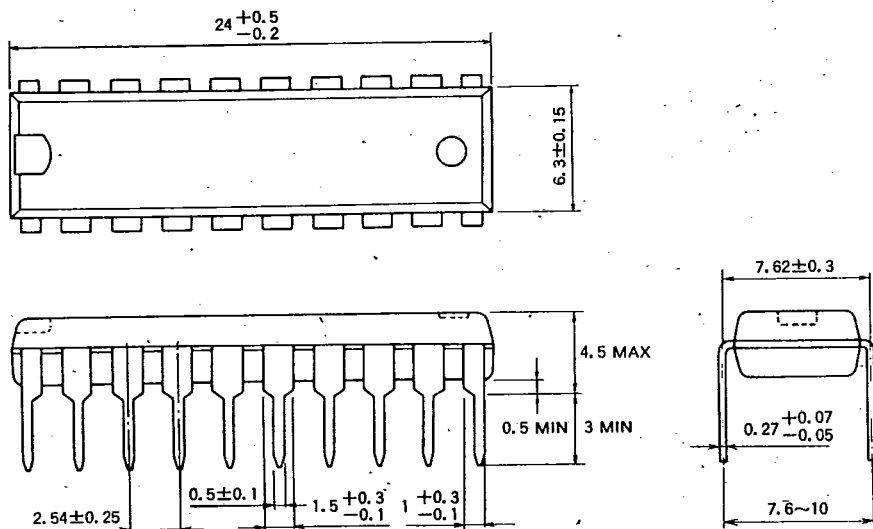

**TYPE 24P4D 24-PIN MOLDED PLASTIC DIP**

Dimension in mm

