

54H/74H78 54LS/74LS78

DUAL JK FLIP-FLOP

(With Common Clear and Clock and Separate Set Inputs)

DESCRIPTION — The 'H78 is a dual JK master/slave flip-flop with separate Direct Set inputs, a common Direct Clear input and a common Clock Pulse input. Inputs to the master section are controlled by the clock pulse. The clock pulse also regulates the circuitry which connects the master and slave sections. The sequence of operation is as follows: 1) isolate slave from master; 2) enter information from J and K inputs to master; 3) disable J and K inputs; 4) transfer information from master to slave. The logic state of the J and K inputs must not be allowed to change when the clock pulse is in a HIGH state.

TRUTH TABLE

INPUTS		OUTPUT
J	K	Q
L	L	Q _n
L	H	L
H	L	H
H	H	Q̄ _n

H = HIGH Voltage Level
L = LOW Voltage Level
t_n = Bit time before clock pulse.
t_{n+1} = Bit time after clock pulse.

CLOCK WAVEFORM

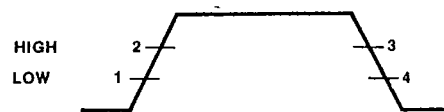

Asynchronous Inputs:
LOW input to \bar{S}_D sets Q to HIGH level
LOW input to \bar{C}_D sets Q to LOW level
Simultaneous LOW on \bar{C}_D and \bar{S}_D makes both Q and \bar{Q} HIGH

The 'LS78 is a dual JK, negative edge-triggered flip-flop which also offers separate Direct Set inputs, a common Direct Clear and common Clock Pulse input. When the Clock Pulse input is HIGH, the JK inputs are enabled and data is accepted. This data will be transferred to the outputs according to the Truth Table on the HIGH-to-LOW clock transitions.

ORDERING CODE: See Section 9

PKGS	PIN OUT	COMMERCIAL GRADE	MILITARY GRADE	PKG TYPE
		V _{CC} = +5.0 V ±5%, T _A = 0°C to +70°C	V _{CC} = +5.0 V ±10%, T _A = -55°C to +125°C	
Plastic DIP (P)	A	74H78PC		9A
	B	74LS78PC		
Ceramic DIP (D)	A	74H78DC	54H78DM	6A
	B	74LS78DC	54LS78DM	
Flatpak (F)	A	74H78FC	54H78FM	3I
	B	74LS78FC	54LS78FM	

CONNECTION DIAGRAMS PINOUT A

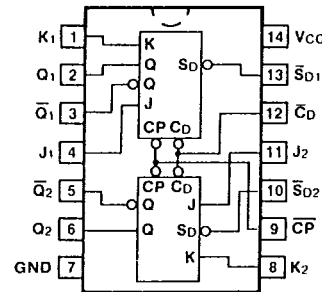

PINOUT B

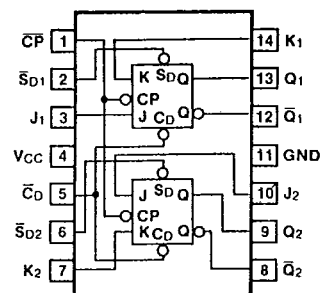

LOGIC SYMBOL

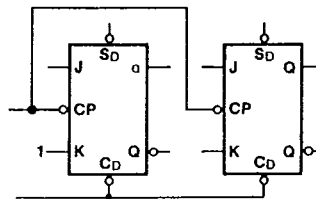

V_{CC} = Pin 14 (4)
GND = Pin 7 (11)

T-46-07-07

INPUT LOADING/FAN-OUT: See Section 3 for U.L. definitions

PIN NAMES	DESCRIPTION	54/74H (U.L.)		54/74LS (U.L.)	
		HIGH/LOW		HIGH/LOW	
J ₁ , J ₂ , K ₁ , K ₂	Data Inputs	1.25/1.25		0.5/0.25	
\overline{CP}	Clock Pulse Input (Active Falling Edge)	2.5/2.5		4.0/1.0	
\overline{CD}	Direct Clear Input (Active LOW)	5.0/5.0		3.0/1.0	
$\overline{SD1}$, $\overline{SD2}$	Direct Set Inputs (Active LOW)	2.5/2.5		1.5/0.5	
Q ₁ , $\overline{Q1}$, Q ₂ , $\overline{Q2}$	Outputs	12.5/12.5		10/5.0 (2.5)	

LOGIC DIAGRAM
(one half shown)

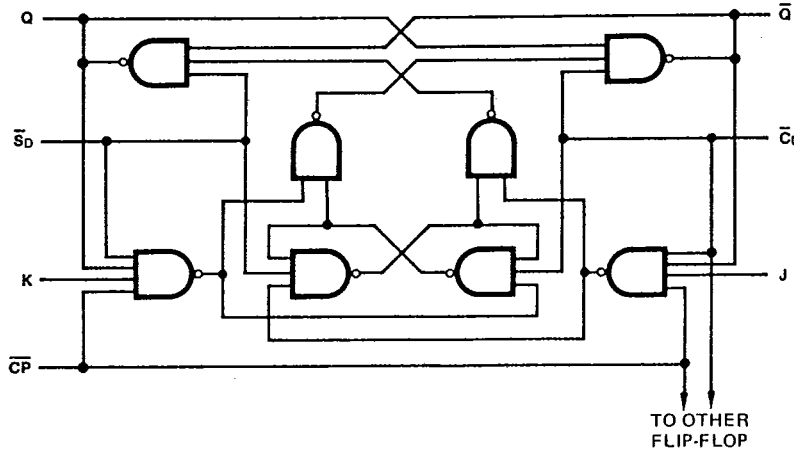

4

DC CHARACTERISTICS OVER OPERATING TEMPERATURE RANGE (unless otherwise specified)

SYMBOL	PARAMETER	54/74H		54/74LS		UNITS	CONDITIONS
		Min	Max	Min	Max		
I _{CC}	Power Supply Current	50		8.0		mA	V _{CC} = Max, V _{CP} = 0 V

AC CHARACTERISTICS: V_{CC} = +5.0 V, T_A = +25°C (See Section 3 for waveforms and load configurations)

SYMBOL	PARAMETER	54/74H		54/74LS		UNITS	CONDITIONS
		C _L = 25 pF R _L = 280 Ω		C _L = 15 pF			
		Min	Max	Min	Max		
f _{max}	Maximum Clock Frequency	25		30		MHz	Figs. 3-1, 3-9
t _{PLH} t _{PHL}	Propagation Delay \overline{CP} to Q _n or \overline{Qn}	21 27		20 30		ns	Figs. 3-1, 3-9
t _{PLH} t _{PHL}	Propagation Delay \overline{CD} or \overline{SDn} to Q _n or \overline{Qn}	13 24		20 30		ns	Figs. 3-1, 3-10

AC OPERATING REQUIREMENTS: $V_{CC} = +5.0\text{ V}$, $T_A = +25^\circ\text{ C}$

SYMBOL	PARAMETER	54/74H		54/74LS		UNITS	CONDITIONS
		Min	Max	Min	Max		
t_s (H)	Setup Time HIGH J_n or K_n to \overline{CP}	0		20		ns	Fig. 3-18 ('H78) Fig. 3-7 ('LS78)
t_h (H)	Hold Time HIGH J_n or K_n to \overline{CP}	0		0		ns	
t_s (L)	Setup Time LOW J_n or K_n to \overline{CP}	0		20		ns	
t_h (L)	Hold Time LOW J_n or K_n to \overline{CP}	0		0		ns	
t_w (H) t_w (L)	\overline{CP} Pulse Width	12 28		20 13.5		ns	Fig. 3-9
t_w (L)	$\overline{C_D}$ or $\overline{S_{Dn}}$ Pulse Width LOW	16		25		ns	Fig. 3-10