

Document Title

**512Kx8 Bit High Speed Static RAM(5V Operating), Revolutionary Pin out.  
Operated at Commercial, Extended and Industrial Temperature Range.**

Revision History

<u>Rev No.</u>	<u>History</u>	<u>Draft Data</u>	<u>Remark</u>
Rev. 0.0	Initial release with Preliminary.	Jun. 1th, 1991	Preliminary
Rev. 1.0	Release to final Data Sheet. 1.1. Delete Preliminary	Oct. 4th, 1993	Final
Rev. 2.0	2.1. Delete 15ns part 2.2. Add 17ns part. 2.3. Add the test condition for Voh <sub>1</sub> with Vcc=5V±5% at 25°C	Apr. 2th, 1994	Final
Rev. 3.0	3.1. Delete Low power product with Data Retention Mode. 3.1.1. Delete Data Retention Characteristics 3.2. Add Industrial and Extended Temperature Range parts with the same parameters as Commercial Temperature Range parts. 3.2.1 Add KM684002I for Industrial Temperature Range. 3.2.2. Add KM684002E for Extended Temperature Range. 3.2.3. Add ordering information. 3.2.4. Add the condition for operating at Industrial and Extended Temperature Range. 3.3. Add timing diagram to define tWP as <b>(Timing Wave Form of Write Cycle(CS=Controlled))</b>	Jun. 17th, 1997	Final

The attached data sheets are prepared and approved by SAMSUNG Electronics. SAMSUNG Electronics CO., LTD. reserve the right to change the specifications. SAMSUNG Electronics will evaluate and reply to your requests and questions on the parameters of this device. If you have any questions, please contact the SAMSUNG branch office near your office, call or contact Headquarters.

512K x 8 Bit High-Speed CMOS Static RAM

FEATURES

- Fast Access Time 17,20,25 $\mu$ S (Max.)
- Low Power Dissipation
  - Standby (TTL) : 60 $\mu$ S (Max.)
  - (CMOS) : 10 $\mu$ S (Max.)
- Operating KM684002 - 17 : 180 $\mu$ S (Max.)
  - KM684002 - 20 : 170 $\mu$ S (Max.)
  - KM684002 - 25 : 160 $\mu$ S (Max.)
- Single 5.0V $\pm$ 10% Power Supply
- TTL Compatible Inputs and Outputs
- I/O Compatible with 3.3V Device
- Fully Static Operation
  - No Clock or Refresh required
- Three State Outputs
- Center Power/Ground Pin Configuration
- Standard Pin Configuration
  - KM684002J : 36-SOJ-400

GENERAL DESCRIPTION

The KM684002 is a 4,194,304-bit high-speed Static Random Access Memory organized as 524,288 words by 8 bits. The KM684002 uses 8 common input and output lines and has an output enable pin which operates faster than address access time at read cycle. The device is fabricated using Samsung's advanced CMOS process and designed for high-speed circuit technology. It is particularly well suited for use in high-density high-speed system applications. The KM684002 is packaged in a 400 mil 36-pin plastic SOJ.

ORDERING INFORMATION

KM684002 -17/20/25	Commercial Temp.
KM684002E -17/20/25	Extended Temp.
KM684002I -17/20/25	Industrial Temp.

PIN CONFIGURATION (Top View)

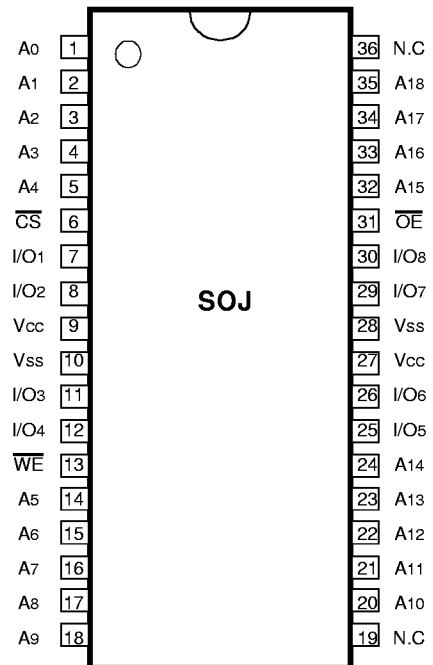

FUNCTIONAL BLOCK DIAGRAM

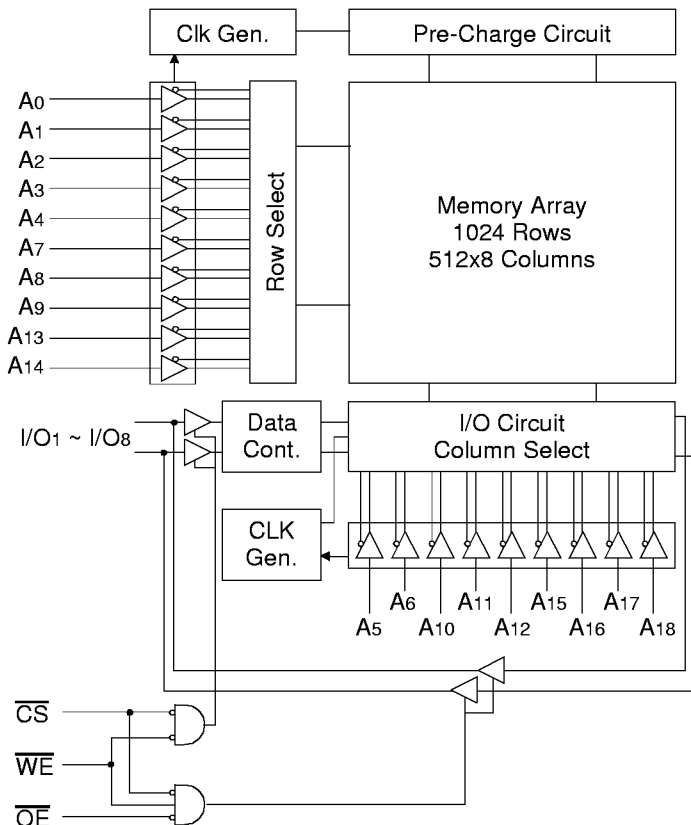

PIN FUNCTION

Pin Name	Pin Function
A0 - A18	Address Inputs
$\overline{WE}$	Write Enable
$\overline{CS}$	Chip Select
$\overline{OE}$	Output Enable
I/O1 ~ I/O8	Data Inputs/Outputs
Vcc	Power(+5.0V)
Vss	Ground
N.C	No Connection

**ABSOLUTE MAXIMUM RATINGS\***

Parameter		Symbol	Rating	Unit
Voltage on Any Pin Relative to Vss		VIN, VOUT	-0.5 to 7.0	V
Voltage on Vcc Supply Relative to Vss		Vcc	-0.5 to 7.0	V
Power Dissipation		Pd	1.0	W
Storage Temperature		TSTG	-65 to 150	°C
Operating Temperature	Commercial	TA	0 to 70	°C
	Extended	TA	-25 to 85	°C
	Industrial	TA	-40 to 85	°C

\* Stresses greater than those listed under "Absolute Maximum Rating" may cause permanent damage to the device. This is a stress rating only and functional operation of the device at these or any other conditions above those indicated in the operating sections of this specification is not implied. Exposure to absolute maximum rating conditions for extended periods may affect reliability.

**RECOMMENDED DC OPERATING CONDITIONS(TA=0 to 70°C)**

Parameter	Symbol	Min	Typ	Max	Unit
Supply Voltage	Vcc	4.5	5.0	5.5	V
Ground	Vss	0	0	0	V
Input Low Voltage	VIH	2.2	-	Vcc+0.5**	V
Input Low Voltage	VIL	-0.5*	-	0.8	V

NOTE: Above parameters are also guaranteed at extended and industrial temperature ranges.

\* VIL(Min) = -2.0V a.c(Pulse Width ≤10ns) for I ≤20S

\*\* VIH(Max) = Vcc + 2.0V a.c (Pulse Width ≤10ns) for I ≤20S

**DC AND OPERATING CHARACTERISTICS(TA=0 to 70°C, Vcc= 5.0V±10%, unless otherwise specified)**

Parameter	Symbol	Test Conditions	Min	Max	Unit	
Input Leakage Current	ILI	VIN = Vss to Vcc	-2	2	µA	
Output Leakage Current	ILO	$\overline{CS}=V_{IH}$ or $\overline{OE}=V_{IH}$ or $\overline{WE}=V_{IL}$ VOUT = Vss to Vcc	-2	2	µA	
Operating Current	ICC	Min. Cycle, 100% Duty $\overline{CS}=V_{IL}$ , VIN = VIH or VIL, IOUT=0mA	17ns	-	180	S
			20ns	-	170	
			25ns	-	160	
Standby Current	ISB	Min. Cycle, $\overline{CS}=V_{IH}$	-	60	S	
	ISB1	f=0MHz, $\overline{CS} \geq V_{cc}-0.2V$ , VIN ≥ Vcc-0.2V or VIN ≤ 0.2V	-	10	S	
Output Low Voltage Level	VOL	IOL=8mA	-	0.4	V	
Output High Voltage Level	VOH	I OH=-4mA	2.4	-	V	
	VOH1*	I OH1=-0.1mA	-	3.95	V	

NOTE: Above parameters are also guaranteed at extended and industrial temperature ranges.

\* Vcc=5.0V±5% Temp. = 25°C

**CAPACITANCE\*(TA=25°C, f=1.0MHz)**

Item	Symbol	Test Conditions	MIN	Max	Unit
Input/Output Capacitance	CI/O	V I/O=0V	-	8	pF
Input Capacitance	CIN	VIN=0V	-	6	pF

\* NOTE : Capacitance is sampled and not 100% tested .

**AC CHARACTERISTICS**( $T_A=0$  to  $70^\circ\text{C}$ ,  $V_{CC}=5.0\text{V}\pm 10\%$ , unless otherwise noted.)

**TEST CONDITIONS**

Parameter	Value
Input Pulse Levels	0V to 3V
Input Rise and Fall Times	3 $\text{\$}$
Input and Output timing Reference Levels	1.5V
Output Loads	See below

NOTE: Above test conditions are also applied at industrial temperature ranges.

Output Loads(A)

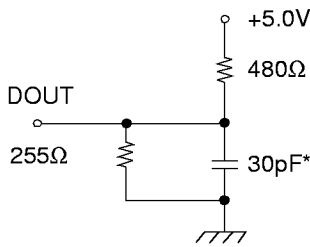

Output Loads(B)  
for tHZ, tLZ, tWHZ, tOW, tOLZ & tOHZ

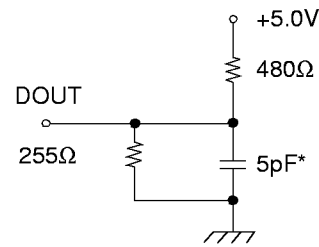

\* Including Scope and Jig Capacitance

**READ CYCLE**

Parameter	Symbol	KM684002-17		KM684002-20		KM684002-25		Unit
		Min	Max	Min	Max	Min	Max	
Read Cycle Time	tRC	17	-	20	-	25	-	$\text{\$}$
Address Access Time	tAA	-	17	-	20	-	25	$\text{\$}$
Chip Select to Output	tCO	-	17	-	20	-	25	$\text{\$}$
Output Enable to Valid Output	tOE	-	8	-	10	-	12	$\text{\$}$
Chip Enable to Low-Z Output	tLZ	3	-	3	-	3	-	$\text{\$}$
Output Enable to Low-Z Output	tOLZ	0	-	0	-	0	-	$\text{\$}$
Chip Disable to High-Z Output	tHZ	0	7	0	8	0	10	$\text{\$}$
Output Disable to High-Z Output	tOHZ	0	7	0	8	0	10	$\text{\$}$
Output Hold from Address Change	tOH	3	-	4	-	5	-	$\text{\$}$
Chip Selection to Power Up Time	tPU	0	-	0	-	0	-	$\text{\$}$
Chip Selection to Power Down Time	tPD	-	17	-	20	-	25	$\text{\$}$

NOTE: Above parameters are also guaranteed at extended and industrial temperature ranges.

WRITE CYCLE

Parameter	Symbol	KM684002-17		KM684002-20		KM684002-25		Unit
		Min	Max	Min	Max	Min	Max	
Write Cycle Time	tWC	17	-	20	-	25	-	§
Chip Select to End of Write	tCW	12	-	13	-	15	-	§
Address Set-up Time	tAS	0	-	0	-	0	-	§
Address Valid to End of Write	tAW	12	-	13	-	15	-	§
Write Pulse Width( $\overline{OE}$ High)	tWP	12	-	13	-	15	-	§
Write Pulse Width( $\overline{OE}$ Low)	tWP1	17	-	20	-	25	-	§
Write Recovery Time	tWR	0	-	0	-	0	-	§
Write to Output High-Z	tWHZ	0	8	0	8	0	10	§
Data to Write Time Overlap	tDW	8	-	9	-	10	-	§
Data Hold from Write Time	tDH	0	-	0	-	0	-	§
End Write to Output Low-Z	tOW	3	-	4	-	5	-	§

NOTE: Above parameters are also guaranteed at extended and industrial temperature ranges.

TIMING DIAGRAMS

TIMING WAVE FORM OF READ CYCLE(1)Address Controlled,  $\overline{CS}=\overline{OE}=V_{IL}$ ,  $\overline{WE}=V_{IH}$

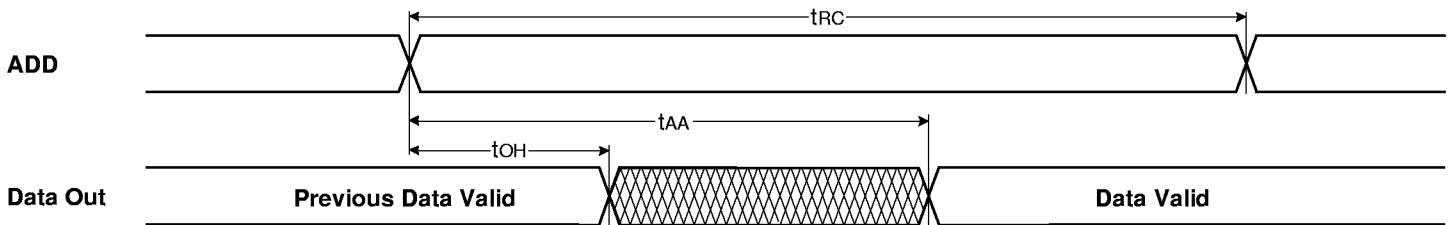

TIMING WAVE FORM OF READ CYCLE(2)  $\overline{WE}=V_{IH}$

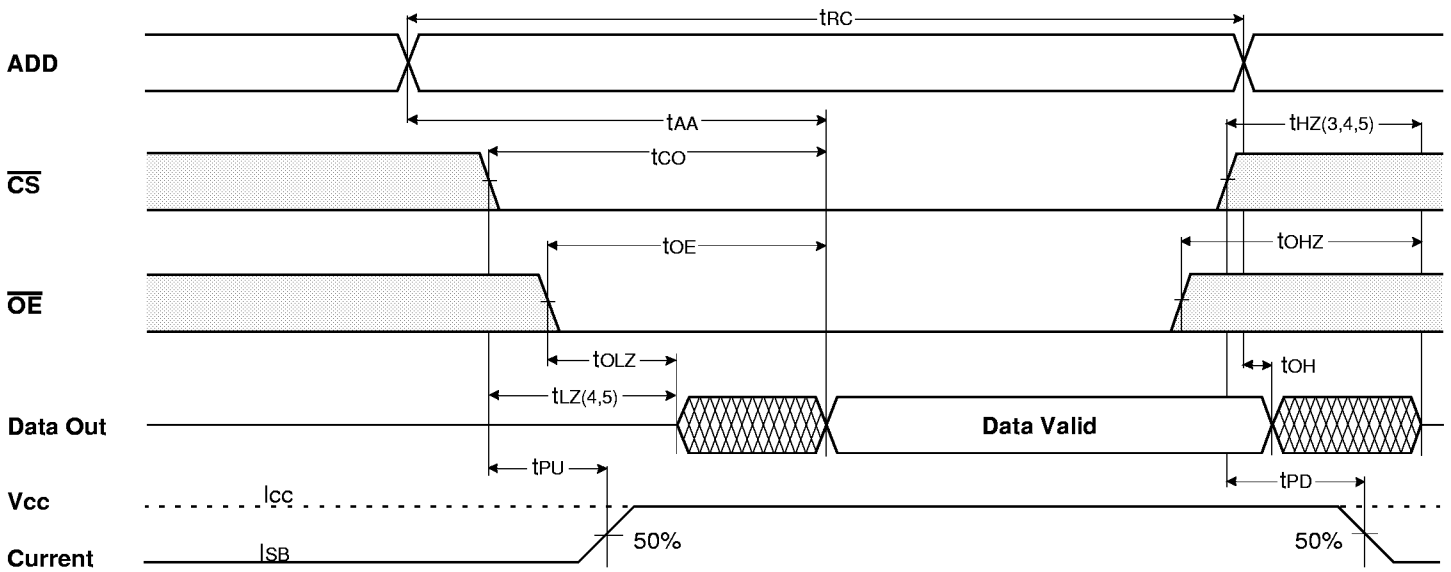

NOTES(READ CYCLE)

1.  $\overline{WE}$  is high for read cycle.
2. All read cycle timing is referenced from the last valid address to the first transition address.
3. tHZ and tOHZ are defined as the time at which the outputs achieve the open circuit condition and are not referenced to  $V_{OH}$  or  $V_{OL}$  Levels.
4. At any given temperature and voltage condition, tHZ(Max.) is less than tLZ(Min.) both for a given device and from device to device.
5. Transition is measured  $\pm 200\text{S}^{\sim}$  from steady state voltage with Load(B). This parameter is sampled and not 100% tested.
6. Device is continuously selected with  $\overline{CS}=V_{IL}$ .
7. Address valid prior to coincident with  $\overline{CS}$  transition low.
8. For common I/O applications, minimization or elimination of bus contention conditions is necessary during read and write cycle.

TIMING WAVE FORM OF WRITE CYCLE(1)  $\overline{OE}=\text{Clock}$

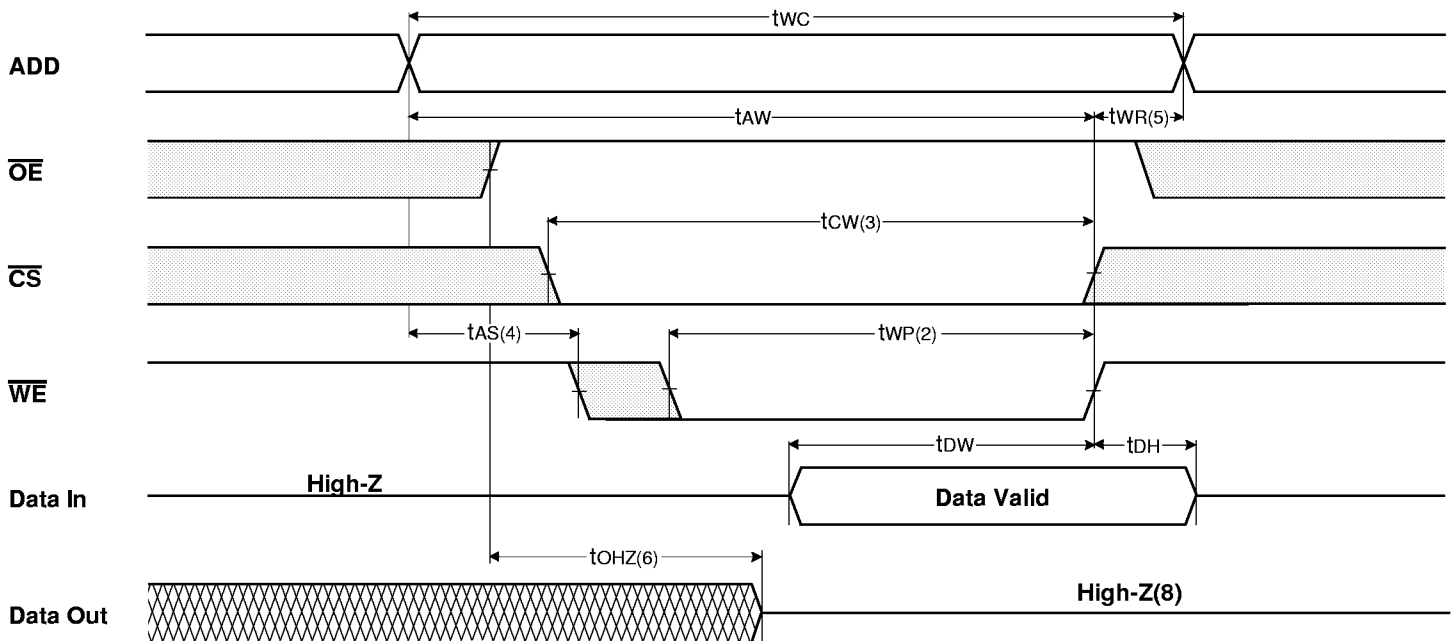

TIMING WAVE FORM OF WRITE CYCLE(2)  $\overline{OE}$ =Low Fixed

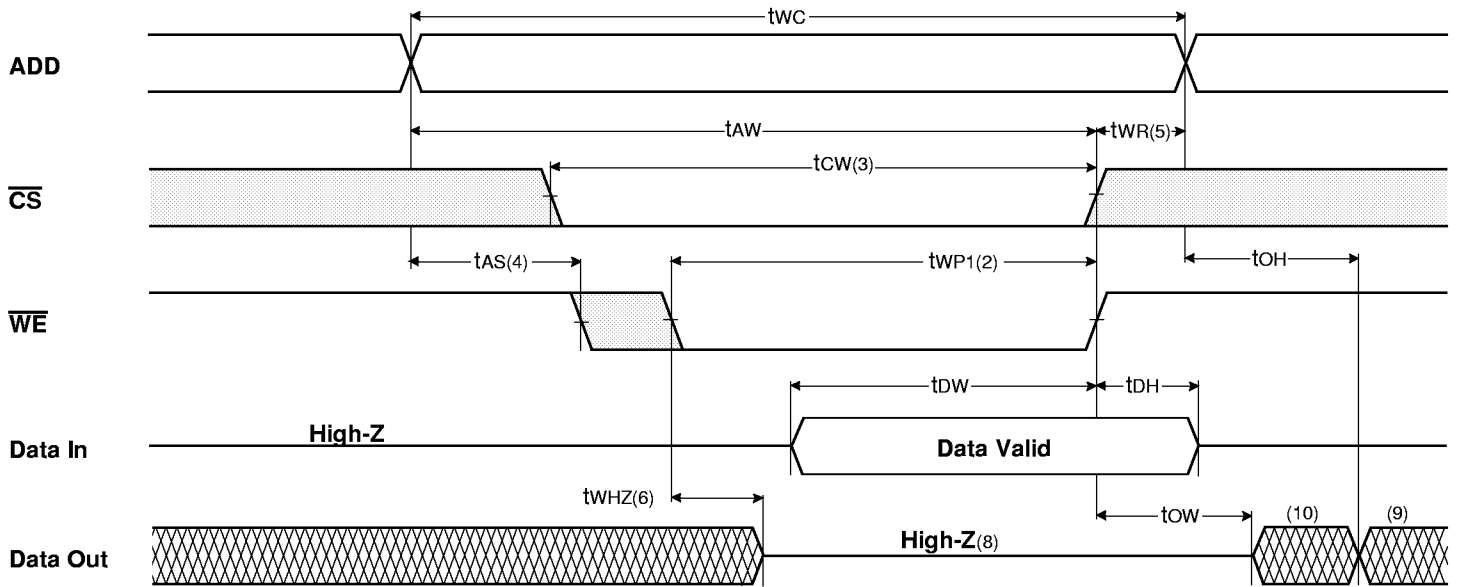

TIMING WAVE FORM OF WRITE CYCLE(3)  $\overline{CS}$ =Controlled

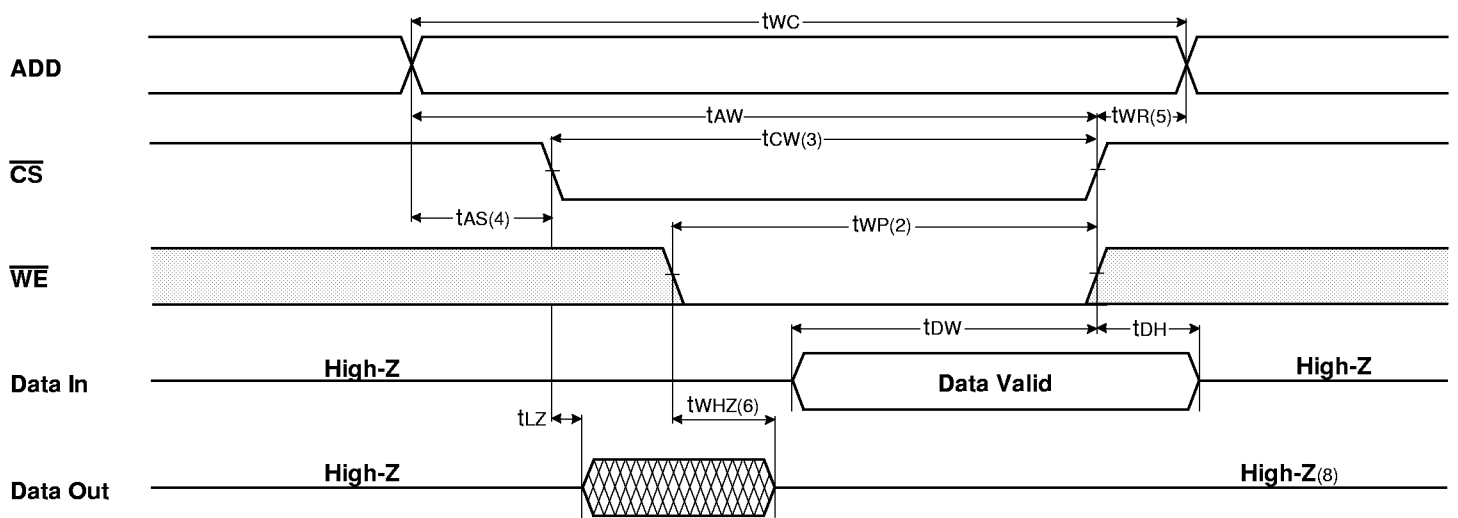

**NOTES(WRITE CYCLE)**

1. All write cycle timing is referenced from the last valid address to the first transition address.
2. A write occurs during the overlap of a low  $\overline{CS}$  and  $\overline{WE}$ . A write begins at the latest transition  $\overline{CS}$  going low and  $\overline{WE}$  going low ; A write ends at the earliest transition  $\overline{CS}$  going high or  $\overline{WE}$  going high.  $t_{WP}$  is measured from the beginning of write to the end of write.
3.  $t_{CW}$  is measured from the later of  $\overline{CS}$  going low to end of write.
4.  $t_{AS}$  is measured from the address valid to the beginning of write.
5.  $t_{WR}$  is measured from the end of write to the address change.  $t_{WR}$  applied in case a write ends as  $\overline{CS}$  or  $\overline{WE}$  going high.
6. If  $\overline{OE}$ ,  $\overline{CS}$  and  $\overline{WE}$  are in the Read Mode during this period, the I/O pins are in the output low-Z state. Inputs of opposite phase of the output must not be applied because bus contention can occur.
7. For common I/O applications, minimization or elimination of bus contention conditions is necessary during read and write cycle.
8. If  $\overline{CS}$  goes low simultaneously with  $\overline{WE}$  going or after  $\overline{WE}$  going low, the outputs remain high impedance state.
9. DOUT is the read data of the new address.
10. When  $\overline{CS}$  is low : I/O pins are in the output state. The input signals in the opposite phase leading to the output should not be applied.

**FUNCTIONAL DESCRIPTION**

$\overline{CS}$	$\overline{WE}$	$\overline{OE}$	Mode	I/O Pin	Supply Current
H	X	X*	Not Select	High-Z	ISB, ISB1
L	H	H	Output Disable	High-Z	I <sub>CC</sub>
L	H	L	Read	DOUT	I <sub>CC</sub>
L	L	X	Write	DIN	I <sub>CC</sub>

\* NOTE : X means Don't Care.



PACKAGE DIMENSIONS

36-SOJ-400

Units : Inches (millimeters)

