

DL4728A THRU DL4761A

List

List..... 1

Package outline..... 2

Features..... 2

Mechanical data..... 2

Maximum ratings 2

Electrical characteristics..... 3

Rating and characteristic curves..... 4

Pinning information..... 5

Suggested solder pad layout..... 5

Packing information..... 6

Reel packing..... 7

Suggested thermal profiles for soldering processes..... 7

High reliability test capabilities..... 8

DL4728A THRU DL4761A

**1000mW Surface Mount
Zener Diodes- 3.3V-75V**

Features

- Silicon epitaxial planar chip structure.
- Surface mount glass hermetically sealed package.
- Wide zener reverse voltage range 3.3V to 75V.
- Other tolerance are available upon request.
- Lead-free parts meet environmental standards of MIL-STD-19500 /228

Mechanical data

- Case : Glass DL-41G
- Terminals :Plated terminals, solderable per MIL-STD-750, Method 2026
- Polarity : Indicated by cathode band
- Mounting Position : Any
- Weight : Approximated 0.01 gram

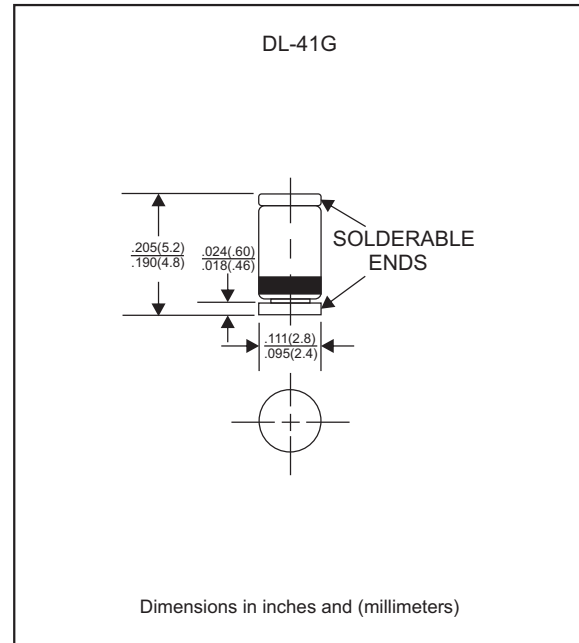
Package outline**MAXIMUM RATINGS** (at $T_A=25^\circ\text{C}$ unless otherwise noted)

PARAMETER	CONDITIONS	Symbol	MIN.	TYP.	MAX.	UNIT
Forward voltage	$I_F = 200 \text{ mA}$	V_F			1.20	V
Power dissipation	$T_{amb} \leq 50^\circ\text{C}$	P_D			1000	mW
Thermal resistance junction to ambient	$l=9.5\text{mm}(3/8")$ TL=constant	$R_{\theta JA}$		100		K/W
Operating junction temperature range		T_J	-55		+150	$^\circ\text{C}$
Storage temperature range		T_{STG}	-65		+175	$^\circ\text{C}$

DL4728A THRU DL4761A

Electrical characteristics (at $T_A=25^\circ\text{C}$ unless otherwise noted)

Part No.	Zener voltage			Test current	Zener impedance			Leakage current	
	$V_Z @ I_{ZT}$ (Volts)			I_{ZT}	$Z_{ZT} @ I_{ZT}$	$Z_{ZK} @ I_{ZK}$	I_{ZK}	I_R	V_R
	Min.	Nom.	Max.	mA	(Ω)Max	(Ω)Max	mA	(μA)Max	Volts
DL4728A	3.14	3.3	3.47	76	10	400	1.00	100	1.0
DL4729A	3.42	3.6	3.78	69	10	400	1.00	100	1.0
DL4730A	3.71	3.9	4.10	64	9	400	1.00	50	1.0
DL4731A	4.09	4.3	4.52	58	9	400	1.00	10	1.0
DL4732A	4.47	4.7	4.94	53	8	500	1.00	10	1.0
DL4733A	4.85	5.1	5.36	49	7	550	1.00	10	1.0
DL4734A	5.32	5.6	5.88	45	5	600	1.00	10	2.0
DL4735A	5.89	6.2	6.51	41	2	700	1.00	10	3.0
DL4736A	6.46	6.8	7.14	37	3.5	700	1.00	10	4.0
DL4737A	7.13	7.5	7.88	34	4.0	700	0.50	10	5.0
DL4738A	7.79	8.2	8.61	31	4.5	700	0.50	10	6.0
DL4739A	8.65	9.1	9.56	28	5	700	0.50	10	7.0
DL4740A	9.50	10	10.5	25	7	700	0.25	10	7.6
DL4741A	10.45	11	11.55	23	8	700	0.25	5	8.4
DL4742A	11.40	12	12.60	21	9	700	0.25	5	9.1
DL4743A	12.35	13	13.65	19	10	700	0.25	5	9.9
DL4744A	14.25	15	15.75	17	14	700	0.25	5	11.4
DL4745A	15.20	16	16.80	15.5	16	700	0.25	5	12.2
DL4746A	17.10	18	18.90	14	20	750	0.25	5	13.7
DL4747A	19.00	20	21.00	12.5	22	750	0.25	5	15.2
DL4748A	20.90	22	23.10	11.5	23	750	0.25	5	16.7
DL4749A	22.80	24	25.20	10.5	25	750	0.25	5	18.2
DL4750A	25.65	27	28.35	9.5	35	750	0.25	5	20.6
DL4751A	28.50	30	31.50	8.5	40	1000	0.25	5	22.8
DL4752A	31.35	33	34.65	7.5	45	1000	0.25	5	25.4
DL4753A	34.20	36	37.80	7.0	50	1000	0.25	5	27.4
DL4754A	37.05	39	40.95	6.5	60	1000	0.25	5	29.7
DL4755A	40.85	43	45.15	6.0	70	1500	0.25	5	32.7
DL4756A	44.65	47	49.35	5.5	80	1500	0.25	5	35.8
DL4757A	48.45	51	53.55	5.0	95	1500	0.25	5	38.8
DL4758A	53.20	56	58.80	4.5	110	2000	0.25	5	42.6
DL4759A	58.90	62	65.10	4.0	125	2000	0.25	5	47.1
DL4760A	64.60	68	71.40	3.7	150	2000	0.25	5	51.7
DL4761A	71.25	75	78.75	3.3	175	2000	0.25	5	56.0

Note : 5% tolerance of Zener voltage

Rating and characteristic curves (DL4728A THRU DL4761A)

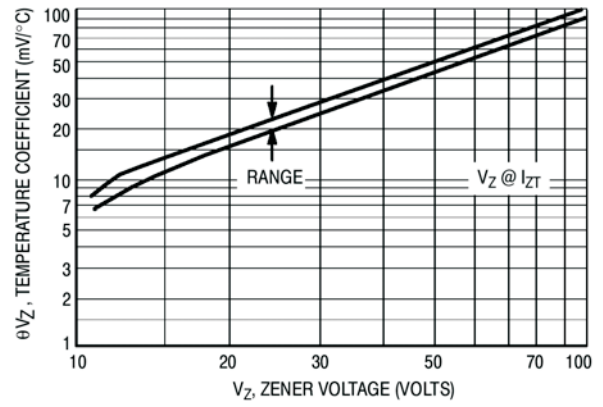
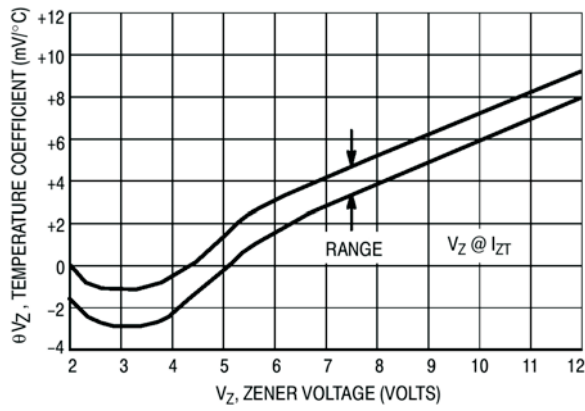

Figure 1. Temperature coefficients

(-55°C to $+150^\circ\text{C}$ temperature range; 90% of the units are in the ranges indicated)

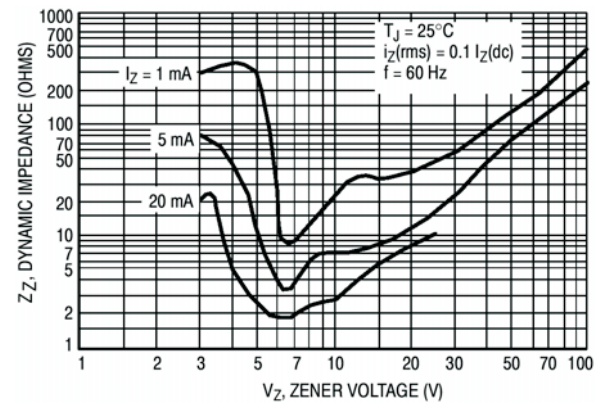
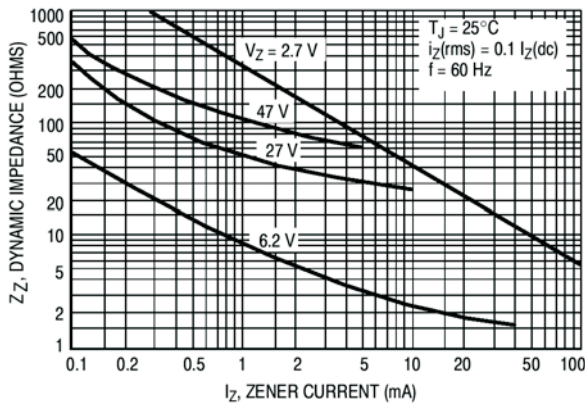

Figure 3. Effect of zener current on zener impedance

Figure 4. Effect of zener voltage on zener impedance

DL4728A THRU DL4761A

Pinning information

Pin	Simplified outline	Symbol
Pin1 cathode Pin2 anode		

Suggested solder pad layout

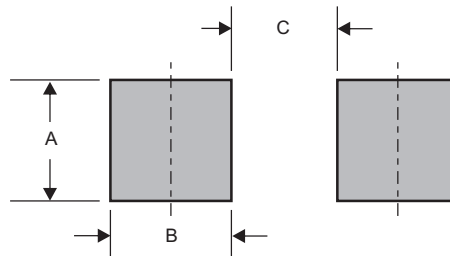

Dimensions in inches and (millimeters)

PACKAGE	A	B	C
DL-41G	0.118 (3.00)	0.079 (2.00)	0.130 (3.30)

DL4728A THRU DL4761A

Packing information

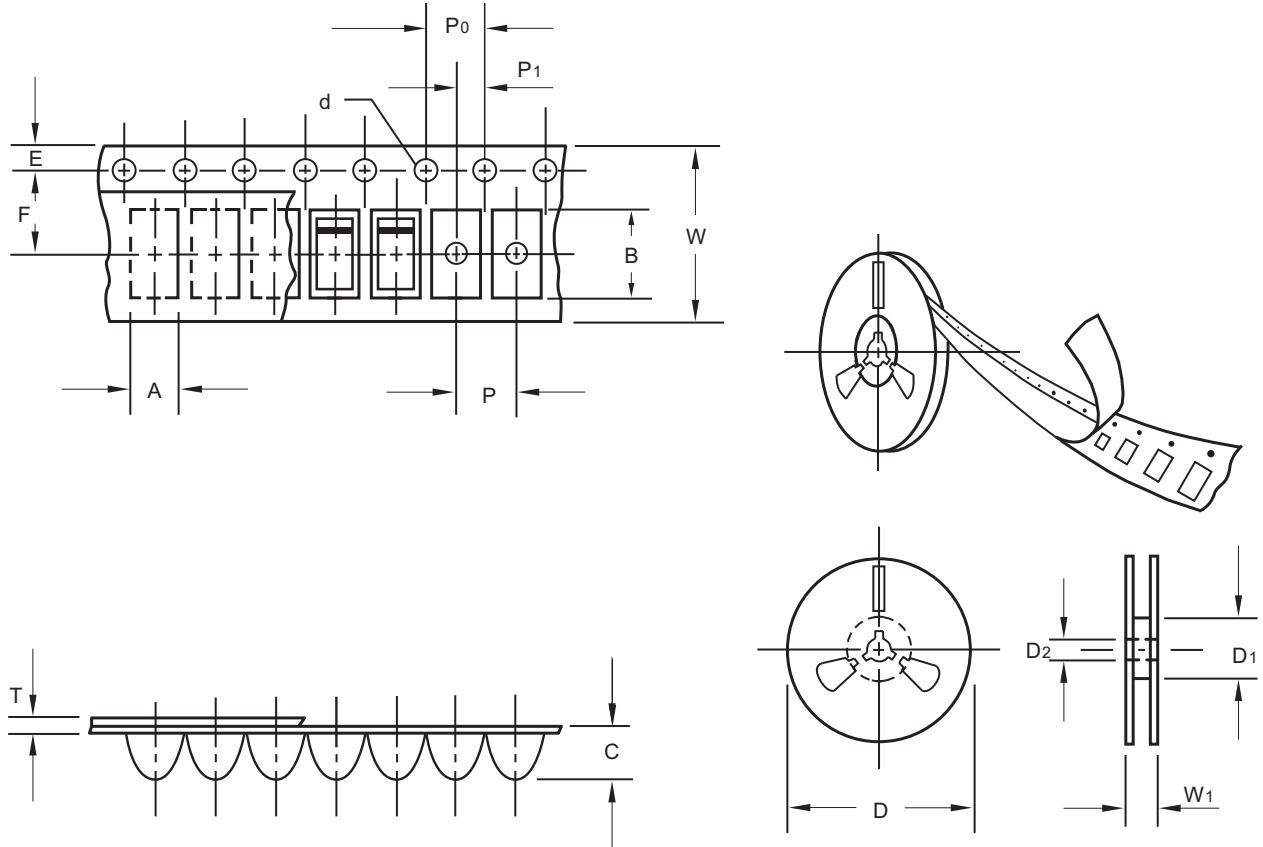

unit:mm

Item	Symbol	Tolerance	DL-41G
Carrier width	A	0.1	3.00
Carrier length	B	0.1	5.30
Carrier depth	C	0.1	2.70
Sprocket hole	d	0.1	1.50
13" Reel outside diameter	D	2.0	330.00
13" Reel inner diameter	D1	min	50.00
7" Reel outside diameter	D	2.0	178.00
7" Reel inner diameter	D1	min	62.00
Feed hole diameter	D2	0.5	13.00
Sprocket hole position	E	0.1	1.75
Punch hole position	F	0.1	5.50
Punch hole pitch	P	0.1	4.00
Sprocket hole pitch	P0	0.1	4.00
Embossment center	P1	0.1	2.00
Overall tape thickness	T	0.1	0.23
Tape width	W	0.3	12.00
Reel width	W1	1.0	18.00

Note: Devices are packed in accordance with EIA standard RS-481-A and specifications listed above.

DL4728A THRU DL4761A

Reel packing

PACKAGE	REEL SIZE	REEL (pcs)	COMPONENT SPACING (m/m)	BOX (pcs)	INNER BOX (m/m)	REEL DIA, (m/m)	CARTON SIZE (m/m)	CARTON (pcs)	APPROX. GROSS WEIGHT (kg)
DL-41G	13"	5,000	4.0	10,000	335*335*38	330	350*330*360	80,000	19.5

Suggested thermal profiles for soldering processes

- 1.Storage environment: Temperature=5°C~40°C Humidity=55%±25%
- 2.Reflow soldering of surface-mount devices

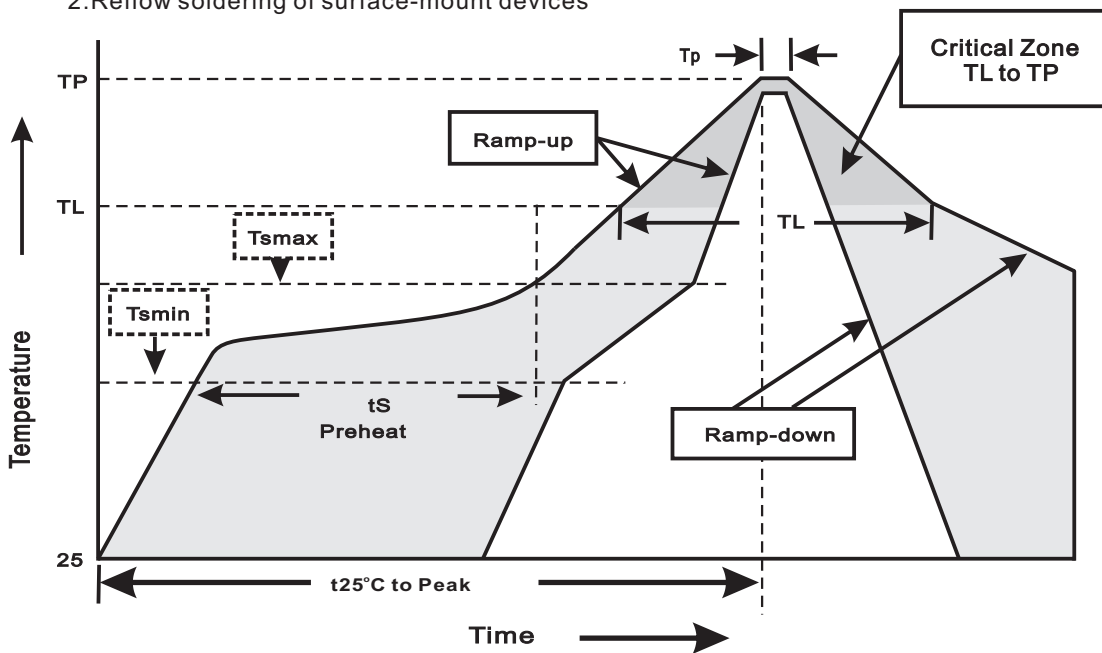

3.Reflow soldering

Profile Feature	Soldering Condition
Average ramp-up rate(T _L to T _P)	<3°C/sec
Preheat -Temperature Min(T _{smmin}) -Temperature Max(T _{smmax}) -Time(min to max)(t _s)	150°C 200°C 60~120sec
T _{smmax} to T _L -Ramp-upRate	<3°C/sec
Time maintained above: -Temperature(T _L) -Time(t _L)	217°C 60~260sec
Peak Temperature(T _P)	255°C-0/+5°C
Time within 5°C of actual Peak Temperature(t _p)	10~30sec
Ramp-down Rate	<6°C/sec
Time 25°C to Peak Temperature	<6minutes

DL4728A THRU DL4761A**High reliability test capabilities**

Item Test	Conditions	Reference
1. Solder Resistance	at 260±5°C for 10±2sec.	MIL-STD-750D METHOD-2031
2. Solderability	at 245±5°C for 5 sec.	MIL-STD-202F METHOD-208
3. High Temperature Reverse Bias	$V_z = V_z \text{ Nom} * 80\%$ at $T_j = 150^\circ\text{C}$ for 168 hrs.	MIL-STD-750D METHOD-1038
4. Pressure Cooker	$15P_{\text{SIE}}$ at $T_A = 121^\circ\text{C}$ for 4 hrs.	JESD22-A102
5. Temperature Cycling	-55°C to +125°C dwelled for 30 min. and transferred for 5min. total 10 cycles.	MIL-STD-750D METHOD-1051
6. Humidity	at $T_A = 85^\circ\text{C}$, RH=85% for 1000hrs.	MIL-STD-750D METHOD-1021
7. High Temperature Storage Life	at 175°C for 1000 hrs.	MIL-STD-750D METHOD-1031