



High Speed CMOS 8-Bit Transceivers

QS54/74FCT245T
QS54/74FCT640T

QS54/74FCT2245T
QS54/74FCT2640T

FEATURES/BENEFITS

- Pin and function compatible to the 74F245/640 and 74FCT245T/640T
- CMOS power levels: <7.5 mW static
- Available in DIP, ZIP, SOIC, QSOP, LCC
- Undershoot clamp diodes on all inputs
- TTL-compatible input and output levels
- Ground bounce controlled outputs
- Reduced output swing of 0-3.5V
- Military product compliant to MIL-STD-883

FCT-T 245T, 640T

- JEDEC-FCT spec compatible
- Fastest CMOS logic family available
- Std., A, C, and D speed grades; 3.8 ns tPD for D
- I_{OL} = 64 mA Com., 48 mA Mil.

FCT-T 2245T, 2640T

- Built-in 25Ω series resistor outputs reduce reflection and other system noise
- Std., A, and C speed grades; 4.1 ns tPD for C
- I_{OL} = 12mA Com.

4

DESCRIPTION

The QSFCT245AT/CT and QSFCT2245AT/CT are 8-bit non-inverting transceivers that have three-state outputs which are useful for bus-oriented applications. The Transmit/Receive (T/R) input determines the direction of data flow, either from A to B or B to A, and the Output Enable (\overline{OE}) input enables the selected port for output. The FCT2245AT/CT and FCT2640AT/CT are 25Ω resistor output versions useful for driving transmission lines and reducing system noise. The 2245 parts can replace the 245 series to reduce noise in an existing design. All inputs have clamp diode for undershoot noise suppression. All outputs have ground bounce suppression (see QSI Application Note AN-001), and outputs will not load an active bus when V_{CC} is removed from the device.

FUNCTIONAL BLOCK DIAGRAM

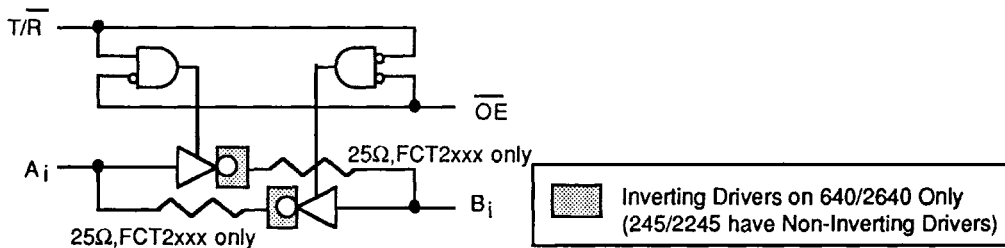

PINOUTS

PDIP, SOIC, QSOP

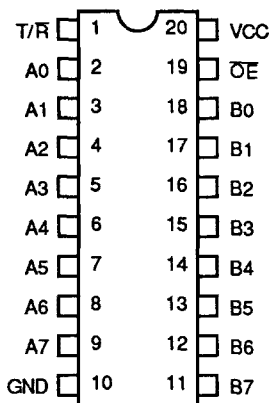

ZIP

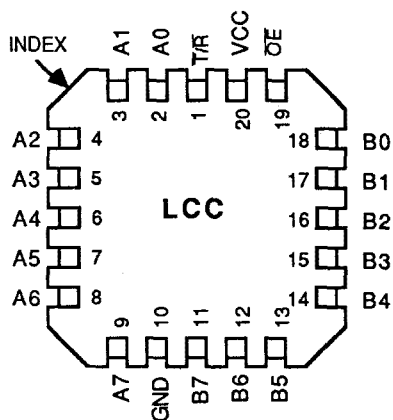
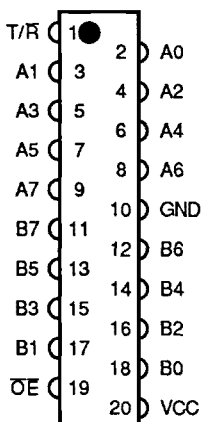

ALL PINS TOP VIEW

PIN DESCRIPTION

Name	I/O	Description
A _i	I/O	Data Bus A
B _i	I/O	Data Bus B
$\overline{T/R}$	I	Direction
\overline{OE}	I	Output Enable

FUNCTION TABLE

\overline{OE}	$\overline{T/R}$	A	B	Function
H	X	Hi-Z	Hi-Z	Disable
L	L	Output	Input	Bus B to Bus A
L	H	Input	Output	Bus A to Bus B

H=High, L=Low, Hi-Z=High Impedance

ABSOLUTE MAXIMUM RATINGS

Supply Voltage to Ground..... -0.5V to +7.0V
 DC Output Voltage V_O -0.5V to 7.0V
 DC Input Voltage V_I -0.5V to 7.0V
 AC Input Voltage (for a pulse width ≤ 20 ns)..... -3.0V
 DC Input Diode Current with $V_I < 0$ -20 mA
 DC Output Diode Current with $V_O < 0$ -50 mA
 DC Output Current Max. sink current/pin..... 120 mA
 Maximum Power Dissipation..... 0.5 watts
 T_{STG} Storage Temperature..... -65° to +165°C

CAPACITANCE

$T_A = 25^\circ\text{C}$, $f = 1\text{ MHz}$, $V_{in} = 0\text{V}$, $V_{out} = 0\text{V}$

Pins	SOIC	QSOP	PDIP, LCC	ZIP	Unit
1,19	4	4	5	7	pF
-----	6	6	7	9	pF
2-9,11-18	8	8	9	10	pF

Note: Capacitance is characterized but not tested



QSFCT245T, 640T, 2245T, 2640T

DC ELECTRICAL CHARACTERISTICS OVER OPERATING RANGE

Commercial $T_A=0^{\circ}\text{C}$ to 70°C , $V_{CC}=5.0\text{V}\pm 5\%$

Military $T_A=-55^{\circ}\text{C}$ to 125°C , $V_{CC}=5.0\text{V}\pm 10\%$

Symbol	Parameter	Test Conditions		Min	Typ (1)	Max	Unit
Vih	Input High Voltage	Logic HIGH for All Inputs		2.0	-	-	Volts
Vil	Input LOW Voltage	Logic LOW for All Inputs		-	-	0.8	
ΔV_I	Input Hysteresis	$V_{Ih} - V_{Il}$ for All Inputs		-	0.2	-	
$ I_{IH} $ $ I_{IL} $	Input Current Input HIGH or LOW	$V_{CC} = \text{MAX}$	$0 \leq V_{in} < V_{CC}$	-	-	5	μA
$ I_{OZ} $	Off State Output Current (Hi-Z)	$V_{CC} = \text{MAX}, 0 \leq V_{in} \leq V_{CC}$		-	-	5	
Ios	Short Circuit Current FCTXXX	$V_{CC} = \text{MAX}, V_o = \text{GND} (2,3)$		-60	-	-225	mA
Ior	Current Drive FCT2XXX (25 Ω)	$V_{CC} = \text{Min}, V_o = 2.0\text{V} (3)$		50	-	-	mA
Vic	Input Clamp Voltage	$V_{CC} = \text{MIN}, I_{in} = 18 \text{mA} (3)$		-	-0.7	-1.2	Volts
Voh	Output HIGH Voltage FCTXXX & FCT2XXX	$V_{CC} = \text{MIN}$	Ioh = 12 mA (MIL)	2.4	-	-	Volts
			Ioh = 15 mA (COM)	2.4	-	-	
Vol	Output LOW Voltage FCTXXX	$V_{CC} = \text{MIN}$	Iol = 48 mA (MIL)	-	-	0.55	
			Iol = 64 mA (COM)	-	-	0.55	
	Output LOW Voltage FCT2XXX (25 Ω)	$V_{CC} = \text{MIN}$	Iol = 12 mA (MIL)	-	-	0.50	
			Iol = 12 mA (COM)	-	-	0.50	
Rout	Output Resistance FCT2XXX (25 Ω)	$V_{CC} = \text{MIN}$	Iol = 12 mA (MIL)	-	25	-	Ω
			Iol = 12 mA (COM)	20	28	40	

Notes:

1. Typical values indicate $V_{CC}=5.0\text{V}$ and $T_A=25^{\circ}\text{C}$.
2. Not more than one output should be shorted and the duration is ≤ 1 second.
3. These parameters are guaranteed by design but not tested.

POWER SUPPLY CHARACTERISTICS

Symbol	Parameter	Test Conditions (1)	Min	Max	Unit
I _{cc}	Quiescent Power Supply Current	V _{cc} = MAX, freq = 0 0V ≤ V _{in} ≤ 0.2V or V _{cc} - 0.2V ≤ V _{in} ≤ V _{cc}	-	1.5	mA
ΔI _{cc}	Supply Current per Input @ TTL HIGH	V _{cc} = MAX, V _{in} = 3.4 V, freq = 0 (2)	-	2.0	
Q _{ccd}	Supply Current per input per MHz	V _{cc} = MAX, Outputs open and enabled One bit toggling @ 50% duty cycle Other inputs at GND or V _{cc} (3,4)	-	0.25	mA/MHz

1. For conditions shown as MIN or MAX use the appropriate values specified under DC specifications.
2. Per TTL driven input (V_i=3.4V)
3. For flipflops Q_{ccd} is measured by switching one of the data input pins so that the output changes every clock cycle. This is a measurement of device power consumption only and does not include power to drive load capacitance or tester capacitance. This parameter is guaranteed by design but not tested.
4. I_c can be computed using the above parameters as explained in the Technical Overview section.



SWITCHING CHARACTERISTICS OVER OPERATING RANGE

Commercial: Ta = 0 °C to 70 °C, V_{cc} = 5.0V ±5% Military: Ta = -55 °C to +125 °C, V_{cc} = 5.0V ±10%
 Load = 50 pF, R_{load} = 500Ω unless otherwise noted.

Symbol	Description	Notes (1)	245, 640, 2245, 2640		245A, 640A, 2245A, 2640A		245C, 2245C		245D		Unit
			Min	Max	Min	Max	Min	Max	Min	Max	
t _{PHL} t _{PLH}	Propagation Delay A _i to/from B _i , 245,640	COM	1.5	7	1.5	4.6	1.5	4.1	1.5	3.8	ns
		MIL	1.5	7.5	1.5	4.9					
	Propagation Delay A _i to/from B _i , 2245,2640	COM	1.5	7	1.5	4.6	1.5	4.1			
		MIL	1.5	7.5	1.5	4.9					
t _{PZH} t _{PZL}	Output Enable Time OE, T/R to A/B, 245,640	COM	1.5	9.5	1.5	6.2	1.5	5.8	1.5	5.6	
		MIL	1.5	10	1.5	6.5					
	Output Enable Time OE, T/R to A/B, 2245,2640	COM	1.5	9.5	1.5	6.2	1.5	5.8			
		MIL	1.5	10	1.5	6.5					
t _{PHZ} t _{PLZ}	Output Disable Time OE, T/R to A/B	COM	2	1.5	7.5	1.5	5	1.5	4.5	1.5	4.5
		MIL	2	1.5	10	1.5	6				

Notes:

- 1) Minimums guaranteed but not tested.
- 2) This parameter is guaranteed by design but not tested.
- 3) See Test Circuit and Waveforms.

