

PRODUCT NUMBER
10082202-YYX-XXLF

- PLATING _____
- 1 = 0.76µm GOLD OR 0.76µm GXT (PdNi) WITH GOLD FLASH ON CONTACT AREA 2µm MATTE TIN ON TAIL
- ROHS COMPATIBLE SEE NOTE 7
- TOTAL NB OF POSITIONS 04 TO 72
- PACKAGING NOTE 3.

| PIN STYLE | DIM "B" | MATING SIDE |
|-----------|---------|-------------|
| 01 | 2.50 | 5.84 |
| 02 | 2.50 | 6.75 |
| 03 | 3.00 | 5.84 |
| 04 | 3.00 | 6.75 |
| 05 | 2.90 | 8.80 |

- 4 = 2µm MATTE TIN ON CONTACT AREA AND TAIL
- 8 = 0.38µm GOLD ON CONTACT AREA 2µm MATTE TIN ON TAIL

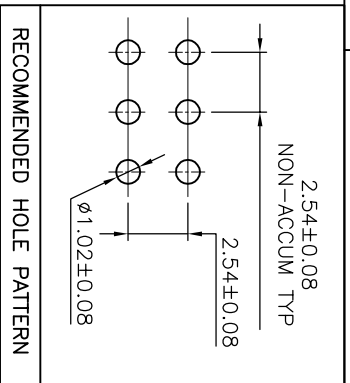
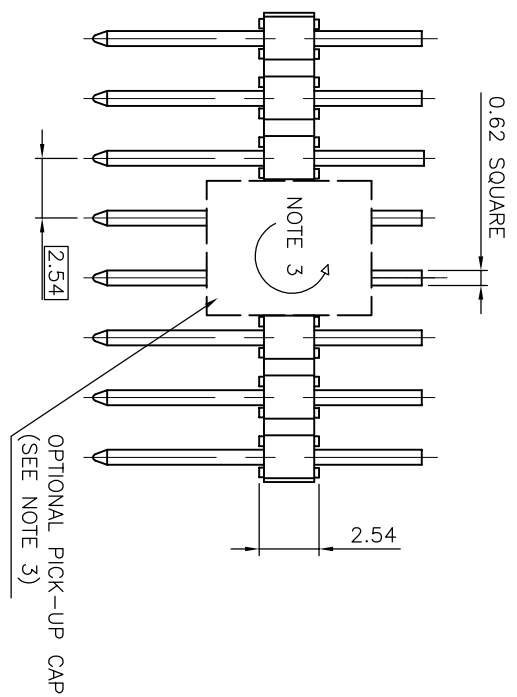

NOTES:

- HOUSING MAT'L : HIGH TEMPERATURE THERMOPLASTIC. UL94V-0 COLOR: BLACK
- PIN MATERIAL : PHOSPHOR BRONZE
- PACKAGING :
 - = POLY BAGS
 - A = TAPE & REEL WITH CAP, SEE TA840 FOR PRODUCT AVAILABILITY.

- 9N MIN RETENTION IN EITHER DIRECTION
- TO DETERMINE DIMENSIONS :
N = NUMBER OF POSITIONS PER ROW
EXAMPLE : 8 POS N x 2.54 = 20.32mm
- UNDERPLATING : 1.27µm Ni MIN

7. ROHS COMPATIBLE PRODUCT SPECIFICATIONS

- a - PLATING:
- "LF" MEANS THE PRODUCT IS LEAD-FREE, 2µm MINIMUM MATTE TIN OVER 1.27µm MINIMUM NICKEL UNDERPLATE.
- b - MANUFACTURING PROCESS COMPATIBILITY
- THE HOUSING WILL WITHSTAND EXPOSURE TO 260°C PEAK TEMP FOR 30 SECONDS IN A CONVECTION, INFRARED, OR VAPOR REFLOW OVEN
- c - LABELING:
- MEETS PACKAGING SPECS AS PER GS-14-920
- d - LEGAL STATEMENT: SEE GS-47-0004

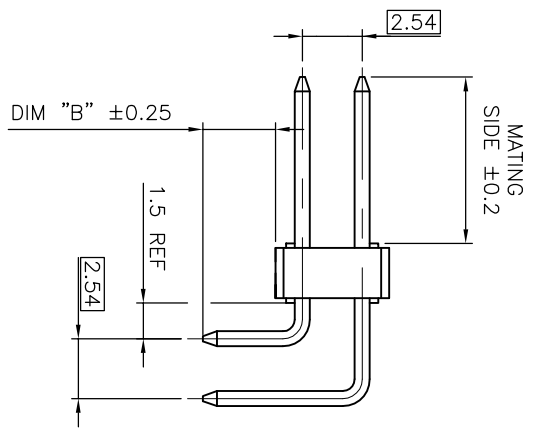
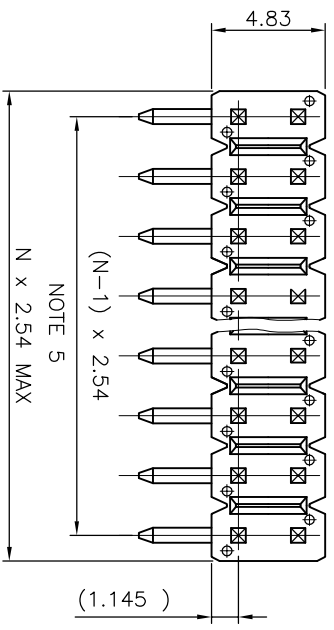

| mat'l. code | surface | tolerance | projection | product family |
|-------------------------|---------------------------------------|------------------|------------|--|
| SEE NOTES | ISO 1302 | ISO 406 ISO 1101 | | BERGSTIK |
| A F08-0104 LMU 08.01.15 | tolerances unless otherwise specified | X ±0.3 | mm | UNSHR.HEADER |
| B F08-0128 LMU 08.02.22 | linear | .XX ±.015 | scale 5:1 | RA DR PIN IN PASTE |
| C F09-0072 J00 09.07.23 | XXX ±0.05 | | | |
| D B-18990 LMU 14.10.06 | LMULIN | 08.01.15 | | |
| E B-20031 AMA 15.01.20 | engr J.COMPAIGNONI | 08.01.15 | | |
| | chr | JM.C | | |
| | apdd | 08.01.15 | | |
| sheet | revision | | | |
| index | sheet | | | |
| | | | | title UNSHR.HEADER RA DR PIN IN PASTE product family BERGSTIK dwg no 10082202 sheet 1 of 1 size A3 CUSTOMER Drawing |