

.079" (2mm) Dual Row Through Hole Vertical Connectors

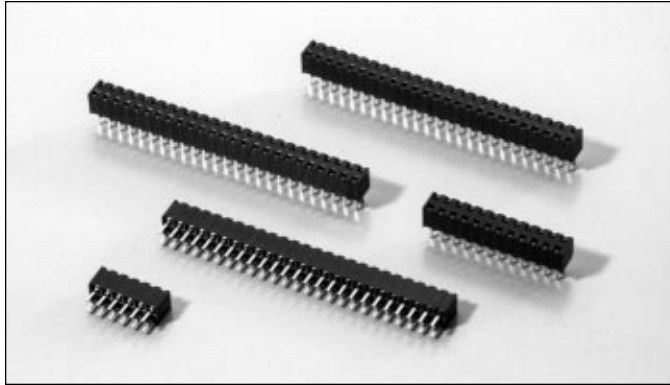

8000 SERIES "POST/BOXE"

PART NUMBER LEGEND

800X-2XX-30X

SOLDER TAIL LENGTH (DIM C)

3 = .110 (2.79)

7 = .050 (1.27)

NUMBER OF POSITIONS PER ROW

2 - 25

CONTACT FINISH

0 = TIN/LEAD

8 = .000030 SELECTIVE GOLD

F = .000015 SELECTIVE GOLD

MATING HEADERS: 8100 SERIES

NOTES:

- INSULATOR MATERIAL: POLYESTER (PCT) UL 94V-0
COLOR: BLACK
- CONTACT MATERIAL: PHOSPHOR BRONZE
- CONTACT PLATING:
 - 8000-2XX-30X: .0001-.0002 90/10 BRITE TIN/LEAD OVER .000050/.000150 NICKEL PLATE.
 - 8002-2XX-30X: .000015 MIN. GOLD PLATE OVER .000050 MIN. NICKEL PLATE
 - 8008-2XX-30X: .000030 SELECTIVE GOLD PLATING AS INDICATED OVER .000050/.000150 NICKEL PLATE ALL OVER; .0002 MIN. TIN/LEAD PLATING ON SOLDER TAIL AS INDICATED.
 - 800F-2XX-30X: .000015 SELECTIVE GOLD PLATING AS INDICATED OVER .000050/.000150 NICKEL PLATE ALL OVER; .0002 MIN. TIN/LEAD PLATING ON SOLDER TAIL AS INDICATED.
- ALL DIMENSIONS ARE IN IN./ (MM)
- CONTACT RETENTION: 1 LB. MINIMUM.

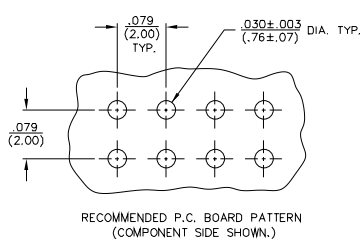
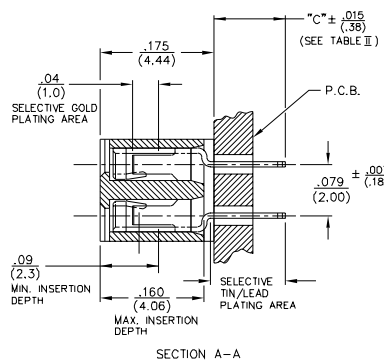
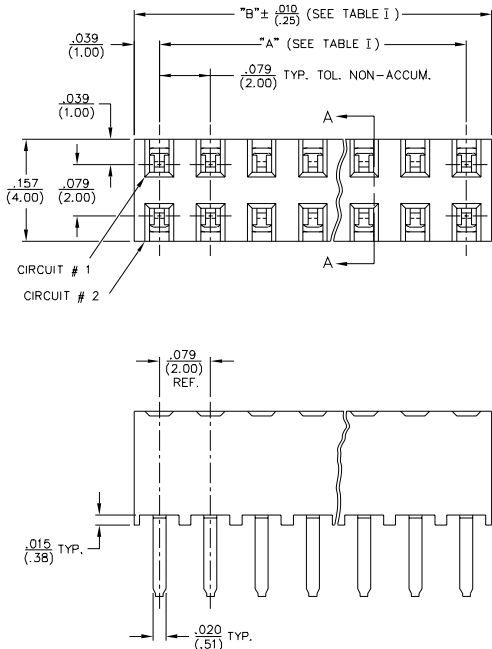

TABLE I

PART NUMBER	NO. OF CIRCUITS	DIM. "A"	DIM. "B"
800X-202-30X	4	.079 (2.00)	.158 (4.00)
-203-	6	.158 (4.00)	.236 (6.00)
-204-	8	.236 (6.00)	.315 (8.00)
-205-	10	.315 (8.00)	.394 (10.00)
-206-	12	.394 (10.00)	.472 (12.00)
-207-	14	.472 (12.00)	.551 (14.00)
-208-	16	.551 (14.00)	.630 (16.00)
-209-	18	.630 (16.00)	.709 (18.00)
-210-	20	.709 (18.00)	.787 (20.00)
-211-	22	.787 (20.00)	.866 (22.00)
-212-	24	.866 (22.00)	.945 (24.00)
-213-	26	.945 (24.00)	1.024 (26.00)
-214-	28	1.024 (26.00)	1.102 (28.00)
-215-	30	1.102 (28.00)	1.181 (30.00)
-216-	32	1.181 (30.00)	1.260 (32.00)
-217-	34	1.260 (32.00)	1.339 (34.00)
-218-	36	1.339 (34.00)	1.417 (36.00)
-219-	38	1.417 (36.00)	1.496 (38.00)
-220-	40	1.496 (38.00)	1.575 (40.00)
-221-	42	1.575 (40.00)	1.654 (42.00)
-222-	44	1.654 (42.00)	1.732 (44.00)
-223-	46	1.732 (44.00)	1.811 (46.00)
-224-	48	1.811 (46.00)	1.890 (48.00)
800X-225-30X	50	1.890 (48.00)	1.968 (50.00)

TABLE II	
PART NUMBER	DIM. "C" $\pm .015$ (.38)
800X-2XX-307	.050 (1.27)
800X-2XX-303	.110 (2.79)

ADDITIONAL SPECIFICATIONS