

1011A



T-43-15-00

# DM74ALS1011A Triple 3-Input AND Buffer

## General Description

These devices contain three independent buffers, each of which performs the logic AND function. The 'ALS1011A is a buffer version of the 'ALS11A.

## Features

- Switching specifications at 50 pF
- Switching specifications guaranteed over full temperature and  $V_{CC}$  range
- Advanced oxide-isolated, ion-implanted Schottky TTL process
- Improved line receiving characteristics

## Connection Diagram

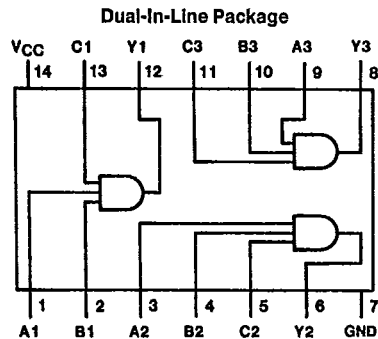

TLJ/F/6256-1

Order Number DM74ALS1011AM or DM74ALS1011AN  
See NS Package Number M14A or N14A

## Function Table

$Y = ABC$

Inputs			Output
A	B	C	Y
L	X	X	L
X	L	X	L
X	X	L	L
H	H	H	H

L = Low Logic Level  
H = High Logic Level  
X = Either Low or High Logic Level

T-43-15

1011A

**Absolute Maximum Ratings**

Supply Voltage	7V
Input Voltage	7V
Operating Free Air Temperature Range DM74ALS	0°C to +70°C
Storage Temperature Range	-65°C to +150°C
Typical $\theta_{JA}$	
N Package	83.0°C/W
M Package	114.0°C/W

Note: The "Absolute Maximum Ratings" are those values beyond which the safety of the device cannot be guaranteed. The device should not be operated at these limits. The parametric values defined in the "Electrical Characteristics" table are not guaranteed at the absolute maximum ratings. The "Recommended Operating Conditions" table will define the conditions for actual device operation.

**Recommended Operating Conditions**

Symbol	Parameter	DM74ALS1011A			Units
		Min	Nom	Max	
V <sub>CC</sub>	Supply Voltage	4.5	5	5.5	V
V <sub>IH</sub>	High Level Input Voltage	2			V
V <sub>IL</sub>	Low Level Input Voltage			0.8	V
I <sub>OH</sub>	High Level Output Current			-2.6	mA
I <sub>OL</sub>	Low Level Output Current			24	mA
T <sub>A</sub>	Free Air Operating Temperature	0		70	°C

**Electrical Characteristics**

over recommended operating free air temperature range. All typical values are measured at V<sub>CC</sub> = 5V, T<sub>A</sub> = 25°C.

Symbol	Parameter	Conditions	Min	Typ	Max	Units	
V <sub>IK</sub>	Input Clamp Voltage	V <sub>CC</sub> = 4.5V, I <sub>I</sub> = -18 mA			-1.5	V	
V <sub>OH</sub>	High Level Output Voltage	V <sub>CC</sub> = 4.5V V <sub>IH</sub> = 2V	I <sub>OH</sub> = Max	2.4	3.2	V	
		V <sub>CC</sub> = 4.5V to 5.5V	I <sub>OH</sub> = -400 $\mu$ A	V <sub>CC</sub> - 2		V	
V <sub>OL</sub>	Low Level Output Voltage	V <sub>CC</sub> = 4.5V V <sub>IL</sub> = V <sub>IL</sub> Max	I <sub>OL</sub> = 12 mA		0.25	0.4	V
			I <sub>OL</sub> = 24 mA		0.35	0.5	V
I <sub>I</sub>	Input Current at Max Input Voltage	V <sub>CC</sub> = 5.5V, V <sub>IH</sub> = 7V			0.1	mA	
I <sub>IH</sub>	High Level Input Current	V <sub>CC</sub> = 5.5V, V <sub>IH</sub> = 2.7V			20	$\mu$ A	
I <sub>IL</sub>	Low Level Input Current	V <sub>CC</sub> = 5.5V, V <sub>IL</sub> = 0.4V			-0.1	mA	
I <sub>O</sub>	Output Drive Current	V <sub>CC</sub> = 5.5V, V <sub>O</sub> = 2.25V	-30		-112	mA	
I <sub>CCH</sub>	Supply Current with Outputs High	V <sub>CC</sub> = 5.5V, V <sub>I</sub> = 4.5V		1.4	2.3	mA	
I <sub>CCL</sub>	Supply Current with Outputs Low	V <sub>CC</sub> = 5.5V, V <sub>I</sub> = 0V		4.3	7	mA	

**Switching Characteristics**

over recommended operating free air temperature range (Note 1).

Symbol	Parameter	Conditions	DM74ALS1011A		Units
			Min	Max	
t <sub>PLH</sub>	Propagation Delay Time Low to High Level Output	V <sub>CC</sub> = 4.5V to 5.5V R <sub>L</sub> = 500 $\Omega$ C <sub>L</sub> = 50 pF	2	10	ns
t <sub>PHL</sub>	Propagation Delay Time High to Low Level Output		3	9	ns

Note 1: See Section 1 for test waveforms and output load.

