

SD1012

RF & MICROWAVE TRANSISTORS VHF FM MOBILE APPLICATIONS

Features

- 175 MHz
- 12.5 VOLTS
- $P_{OUT} = 4$ WATTS
- $G_P = 4.7$ dB MINIMUM
- COMMON EMITTER CONFIGURATION



DESCRIPTION:

The SD1012 is an epitaxial silicon NPN planar transistor designed primarily for VHF mobile and marine transmitters. The device utilizes emitter ballasting resistors and improved metallization systems to achieve extreme ruggedness under Severe operating conditions.

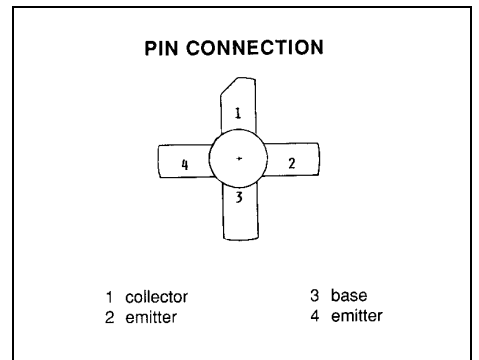

ABSOLUTE MAXIMUM RATINGS (T_{case} = 25°C)

Symbol	Parameter	Value	Unit
V_{CBO}	Collector-Base Voltage	36	V
V_{CEO}	Collector-Emitter Voltage	18	V
V_{EBO}	Emitter-Base Voltage	4.0	V
I_C	Device Current	1.0	A
P_{DISS}	Power Dissipation	12	W
T_J	Junction Temperature	+200	°C
T_{STG}	Storage Temperature	-65 to +150	°C

Thermal Data

$R_{TH(J-C)}$	Thermal Resistance Junction-case	15	°C/W
---------------	----------------------------------	----	------

ELECTRICAL SPECIFICATIONS (T_{case} = 25°C)

STATIC

Symbol	Test Conditions		Value			Unit
			Min.	Typ.	Max.	
BV _{CES}	I _C = 5 mA	V _{BE} = 0 V	36	---	---	V
BV _{CEO}	I _C = 10 mA	I _B = 0 mA	18	---	---	V
BV _{EBO}	I _E = 1 mA	I _C = 0 mA	4.0	---	---	V
I _{CBO}	V _{CB} = 15 V	I _E = 0 mA	---	---	.25	mA
HFE	V _{CE} = 5 V	I _C = 0.25 A	10	---	200	---

DYNAMIC

Symbol	Test Conditions			Value			Unit
				Min.	Typ.	Max.	
P _{OUT}	f = 175 MHz	P _{IN} = 0.25 W	V _{CE} = 12.5 V	4	---	---	W
G _p	f = 175 MHz	P _{IN} = 0.25 W	V _{CE} = 12.5 V	12	---	---	dB
η _c	f = 175 MHz	P _{IN} = 0.25 W	V _{CE} = 12.5 V	50	---	---	%
Cob	f = 1 MHz	V _{CB} = 15 V		---	---	20	pf

IMPEDANCE DATA

FREQ	Z _{IN} (Ω)	Z _{CL} (Ω)
175 MHz	2.2 + j1.3	7.6 + j9.8

P_{IN} = 0.25W

V_{CC} = 12.5V

PACKAGE MECHANICAL DATA

PACKAGE STYLE M135

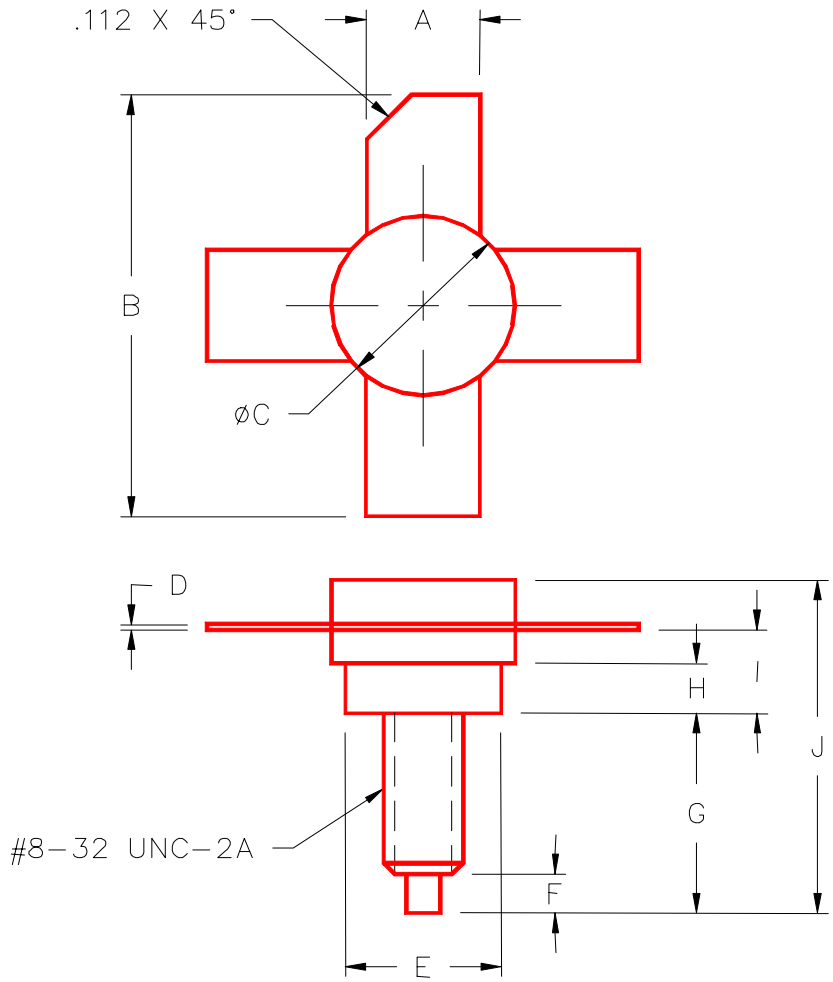

	MINIMUM INCHES/MM	MAXIMUM INCHES/MM		MINIMUM INCHES/MM	MAXIMUM INCHES/MM
A	.220/5,59	.230/5,84	I	.155/3,94	.175/4,45
B	.980/24,89		J		.750/19,05
C	.370/9,40	.385/9,78			
D	.004/0,10	.007/0,18			
E	.320/8,13	.330/8,38			
F	.100/2,54	.130/3,30			
G	.450/11,43	.490/12,45			
H	.090/2,29	.100/2,54			