

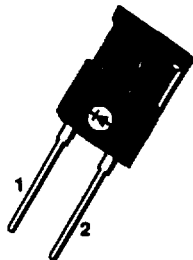

1 - Cathode
2 - Anode
Back of Case - Cathode



APT30D60B 600V 30A
APT30D50B 500V 30A

ULTRAFAST SOFT RECOVERY RECTIFIER DIODE

| PRODUCT APPLICATIONS | PRODUCT FEATURES | PRODUCT BENEFITS |
|--|--|---|
| <ul style="list-style-type: none"> • Anti-Parallel Diode -Switchmode Power Supply -Inverters • Free Wheeling Diode -Motor Controllers -Converters • Snubber Diode • Uninterruptible Power Supply (UPS) • Induction Heating • High Speed Rectifiers | <ul style="list-style-type: none"> • Ultrafast Recovery Times • Soft Recovery Characteristics • Popular TO-247 Package • Low Forward Voltage • High Blocking Voltage • Low Leakage Current | <ul style="list-style-type: none"> • Low Losses • Low Noise Switching • Cooler Operation • Higher Reliability Systems • Increased System Power Density |

MAXIMUM RATINGS

All Ratings: $T_C = 25^\circ\text{C}$ unless otherwise specified.

| Symbol | Characteristic / Test Conditions | APT30D60B-50B | UNIT |
|----------------|---|---------------|------------------|
| V_R | Maximum D.C. Reverse Voltage | 600-500 | Volts |
| V_{RRM} | Maximum Peak Repetitive Reverse Voltage | | |
| V_{RWM} | Maximum Working Peak Reverse Voltage | | |
| $I_F(AV)$ | Maximum Average Forward Current ($T_C = 100^\circ\text{C}$, Duty Cycle = 0.5) | 30 | Amps |
| $I_F(RMS)$ | RMS Forward Current | 70 | |
| I_{FSM} | Non-Repetitive Forward Surge Current ($T_J = 45^\circ\text{C}$, 8.3ms) | 320 | |
| T_J, T_{STG} | Operating and Storage Temperature Range | -55 to 150 | $^\circ\text{C}$ |
| T_L | Lead Temperature: 0.063" from Case for 10 Sec. | 300 | |

STATIC ELECTRICAL CHARACTERISTICS

| Symbol | Characteristic / Test Conditions | MIN | TYP | MAX | UNIT |
|----------|--|-----|-----|--------------------|---------------|
| V_F | Maximum Forward Voltage | | | 1.6 | Volts |
| | | | | $I_F = 30\text{A}$ | |
| | | | | $I_F = 60\text{A}$ | |
| I_{RM} | Maximum Reverse Leakage Current | | | 250 | μA |
| | | | | $V_R = V_R$ Rated | |
| C_T | Junction Capacitance, $V_R = 200\text{V}$ | | 40 | | pF |
| | | | | | |
| L_S | Series Inductance (Lead to Lead 5mm from Base) | | 10 | | nH |

405 S.W. COLUMBIA STREET
BEND, OREGON 97702-1035
U.S.A.

PHONE . . . (503) 382-8028

FAX (503) 388-0364

DYNAMIC CHARACTERISTICS

APT30D60B-50B

| Symbol | Characteristic | MIN | TYP | MAX | UNIT |
|------------|---|--|-----|------|------------|
| t_{rr1} | Reverse Recovery Time, $I_F = 1.0A$, $di_F/dt = -15A/\mu S$, $V_R = 30V$, $T_J = 25^\circ C$ | | 50 | 65 | nS |
| t_{rr2} | Reverse Recovery Time | | 50 | 65 | |
| t_{rr3} | $I_F = 30A$, $di_F/dt = -240A/\mu S$, $V_R = 350V$ | | 80 | 180 | |
| t_{fr1} | Forward Recovery Time | | 155 | | Volts |
| t_{fr2} | $I_F = 30A$, $di_F/dt = 240A/\mu S$, $V_R = 350V$ | | 155 | | |
| I_{RRM1} | Reverse Recovery Current | | 4 | 10 | Amps |
| I_{RRM2} | $I_F = 30A$, $di_F/dt = -240A/\mu S$, $V_R = 350V$ | | 7.5 | 15 | |
| Q_{rr1} | Recovery Charge | | 100 | 325 | nC |
| Q_{rr2} | $I_F = 30A$, $di_F/dt = -240A/\mu S$, $V_R = 350V$ | | 300 | 1350 | |
| V_{fr1} | Forward Recovery Voltage | | 3 | | Volts |
| V_{fr2} | $I_F = 30A$, $di_F/dt = 240A/\mu S$, $V_R = 350V$ | | 3 | | |
| di/dt | Rate of Fall of Recovery Current | | 400 | | A/ μS |
| | | $I_F = 30A$, $di_F/dt = -240A/\mu S$, $V_R = 350V$ (See Figure 10) | | 200 | |

THERMAL AND MECHANICAL CHARACTERISTICS

| Symbol | Characteristic / Test Conditions | MIN | TYP | MAX | UNIT |
|-----------------|--|-----|------|------|--------------|
| $R_{\theta JC}$ | Junction-to-Case Thermal Resistance | | | 0.90 | $^\circ C/W$ |
| $R_{\theta JA}$ | Junction-to-Ambient Thermal Resistance | | | 40 | |
| W_T | Package Weight | | 0.22 | | oz |
| | | | 6.1 | | gm |
| Torque | Maximum Mounting Torque (Screw Type = 6-32 or 3mm Machine) | | | 10 | lb-in |
| | | | | 1.1 | Nm |

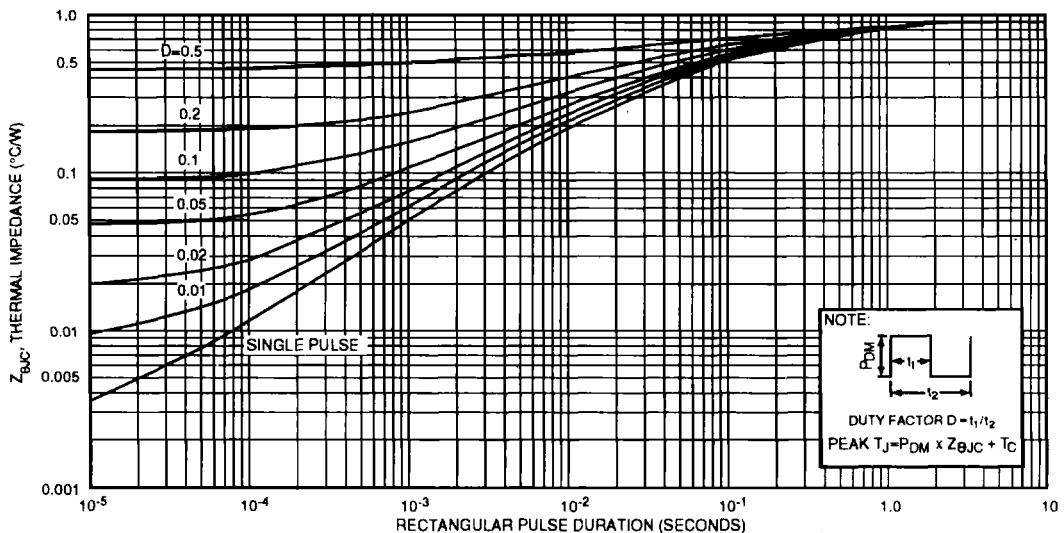

FIGURE 1, MAXIMUM EFFECTIVE TRANSIENT THERMAL IMPEDANCE, JUNCTION-TO-CASE vs PULSE DURATION

APT30D60B-50B

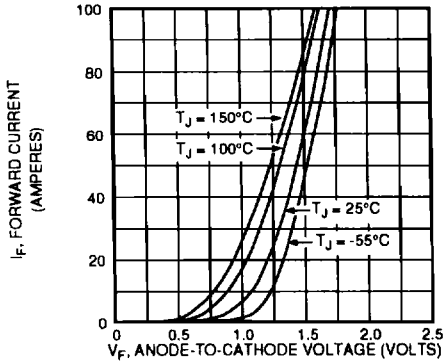

Figure 2, Forward Voltage Drop vs Forward Current

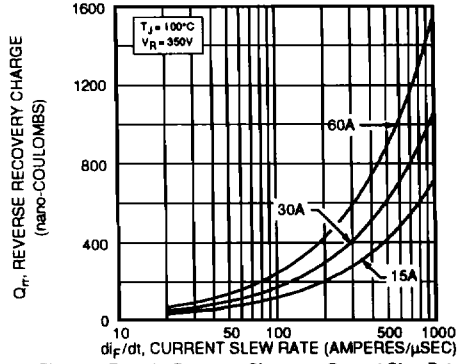

Figure 3, Reverse Recovery Charge vs Current Slew Rate

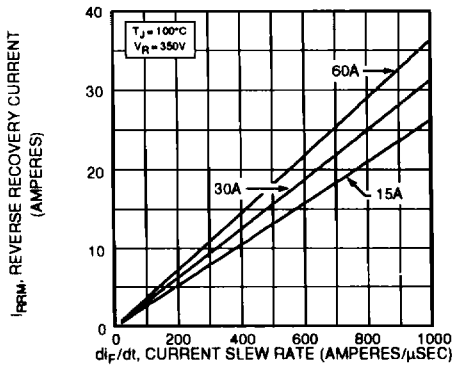

Figure 4, Reverse Recovery Current vs Current Slew Rate

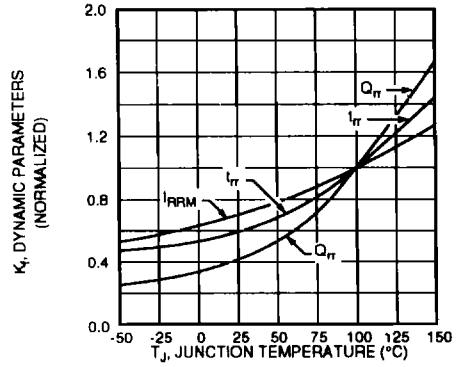

Figure 5, Dynamic Parameters vs Junction Temperature

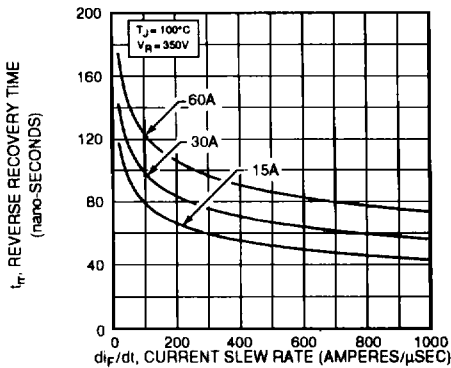

Figure 6, Reverse Recovery Time vs Current Slew Rate

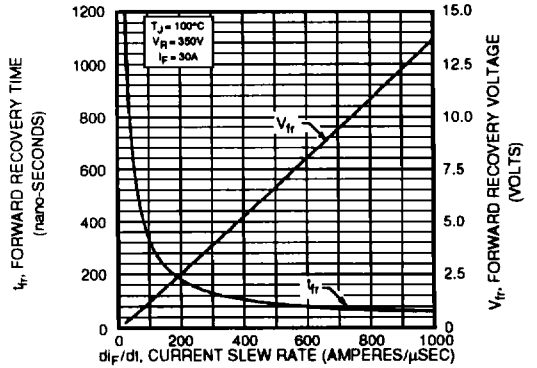

Figure 7, Forward Recovery Voltage/Time vs Current Slew Rate

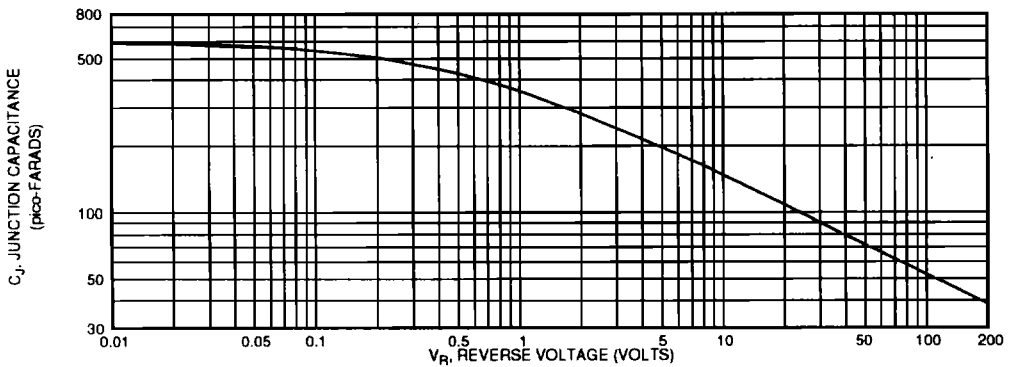

Figure 8, Junction Capacitance vs Reverse Voltage

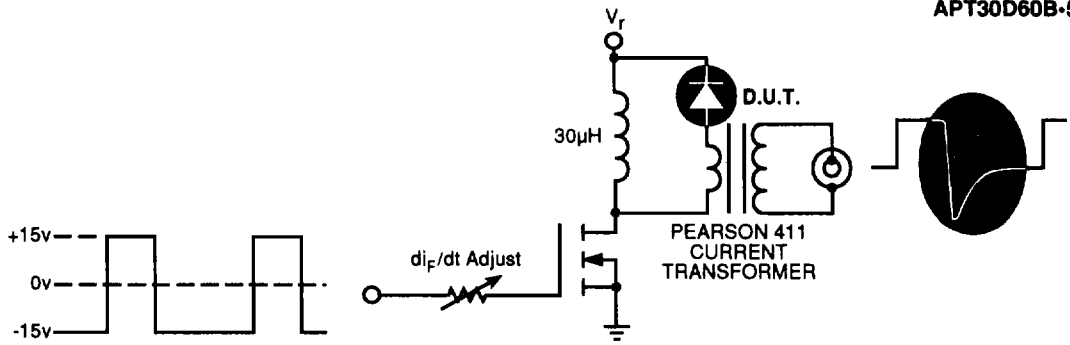

Figure 9, Diode Reverse Recovery Test Circuit and Waveforms

1 I_F - Forward Conduction Current

2 di_F/dt - Current Slew Rate, Rate of Forward Current Change Through Zero Crossing.

3 I_{RRM} - Peak Reverse Recovery Current.

4 t_{rr} - Reverse Recovery Time Measured from Point of I_F Current Falling Through Zero to a Tangent Line {6 diM/dt } Extrapolated Through Zero Defined by 0.75 and 0.50 I_{RRM} .

5 Q_{rr} - Area Under the Curve Defined by I_{RRM} and t_{rr} .

6 diM/dt - Maximum Rate of Current Change During the Trailing Portion of t_{rr} .

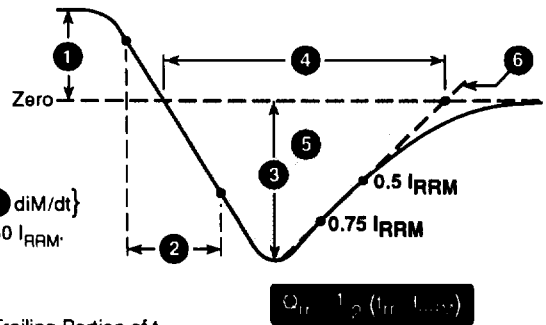
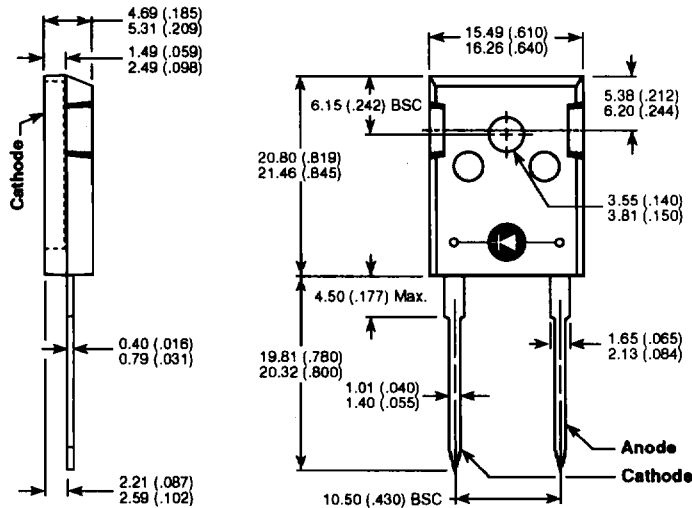

Figure 10, Diode Reverse Recovery Waveform and Definitions

TO-247AD Package Outline



Dimensions in Millimeters and (Inches)