



# M54/74HC160/161 M54/74HC162/163

## SGS-THOMSON T-45-23-05 SYNCHRONOUS PRESETTABLE 4-BIT COUNTER

- HIGH SPEED  
 $f_{MAX} = 50$  MHz (TYP.) at  $V_{CC} = 5$  V
- LOW POWER DISSIPATION  
 $I_{CC} = 4$   $\mu$ A (MAX.) at 25°C
- OUTPUT DRIVE CAPABILITY  
10 LSTTL LOADS
- BALANCED PROPAGATION DELAYS  
 $t_{PLH} = t_{PHL}$
- HIGH NOISE IMMUNITY  
 $V_{NIH} = V_{NIL} = 28\%$   $V_{CC}$  (MIN).
- WIDE OPERATING VOLTAGE RANGE  
 $V_{CC}$  (OPR) = 2V to 6V
- PIN AND FUNCTION COMPATIBLE  
WITH 54/74LS160 ~ 163

**B1N** Plastic Package      **F1** Ceramic Frit Seal Package

**M1** Micro Package      **C1** Plastic Chip Carrier

ORDERING NUMBERS:  
M54HCXXX F1      M74HCXXX C1  
M74HCXXX B1N      M74HCXXX M1  
M74HCXXX F1

### DESCRIPTION

M54/74HC160 Decade, Asynchronous Clear  
M54/74HC161 Binary, Asynchronous Clear  
M54/74HC162 Decade, Synchronous Clear  
M54/74HC163 Binary, Synchronous Clear

The M54/74HC160, 161, 162 and 163 are high speed CMOS SYNCHRONOUS PRESETTABLE COUNTERS fabricated with silicon gate C<sup>2</sup>MOS technology.

They have the same the high speed operation similar to equivalent LSTTL while maintaining the CMOS low power dissipation.

The M54/74HC160/162 are BCD Decade counters and the M54/74HC161/163 are 4 bit binary counters.

The CLOCK input is active on the rising edge. Both LOAD and CLEAR inputs are active Low.

Presetting of all four IC's is synchronous on the rising edge of the CLOCK.

The function on the M54/74HC162/163 is synchronous to CLOCK, while the M54/74HC160/161 counters are cleared asynchronously.

Two enable inputs (TE and PE) and CARRY output are provided to enable easy cascading of counters, which facilitates easy implementation of N-bit counters without using external gates.

All inputs are equipped with protection circuits against static discharge and transient excess voltage.

### PIN CONNECTIONS (top view)

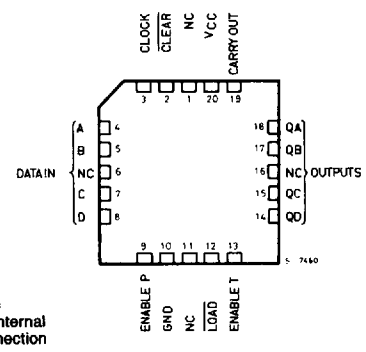
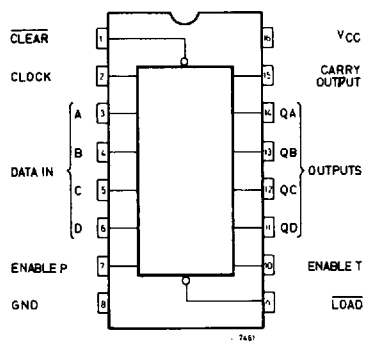

NC = No Internal Connection

TRUTH TABLE

S G S-THOMSON 56E D

M54/74HC160/161					M54/74HC162/163					OUTPUTS				FUNCTION
INPUTS					INPUTS					QA	QB	QC	QD	
CLR	LD	PE	TE	CK	CLR	LD	PE	TE	CK	QA	QB	QC	QD	
L	X	X	X	X	L	X	X	X		L	L	L	L	RESET TO "0"
H	L	X	X		H	L	X	X		A	B	C	D	PRESET DATA
H	H	X	L		H	H	X	L		NO CHANGE				NO COUNT
H	H	L	X		H	H	L	X		NO CHANGE				NO COUNT
H	H	H	H		H	H	H	H		COUNT UP				COUNT
H	X	X	X		X	X	X	X		NO CHANGE				NO COUNT

Note X : DON'T CARE  
 A, B, C, D : LOGIC LEVEL OF DATA INPUTS  
 Carry :  $CARRY = TE \cdot Q_A \cdot \bar{Q}_B \cdot \bar{Q}_C \cdot Q_D$  ..... (M54/74HC160/162)  
 CARRY =  $TE \cdot Q_A \cdot Q_B \cdot Q_C \cdot Q_D$  ..... (M54/74HC161/163)

TIMING CHART (HC160/162: DECADE COUNTER)

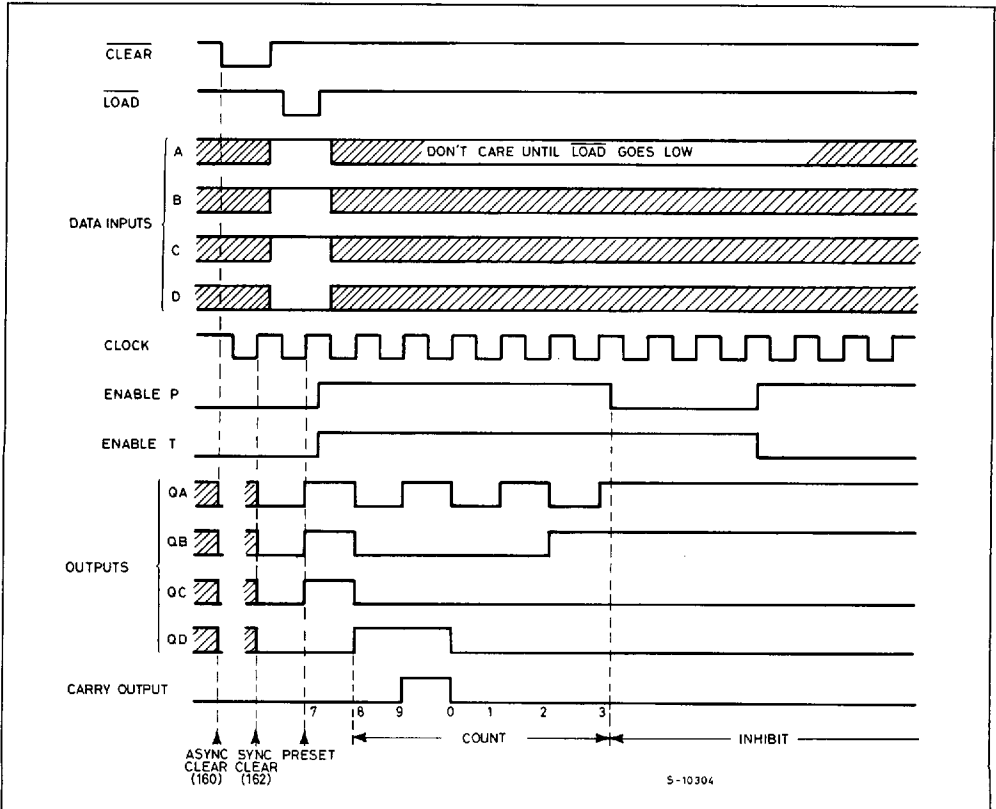

S-10304

TIMING CHART (HC161/163: BINARY COUNTER)

SGS-THOMSON

56E D

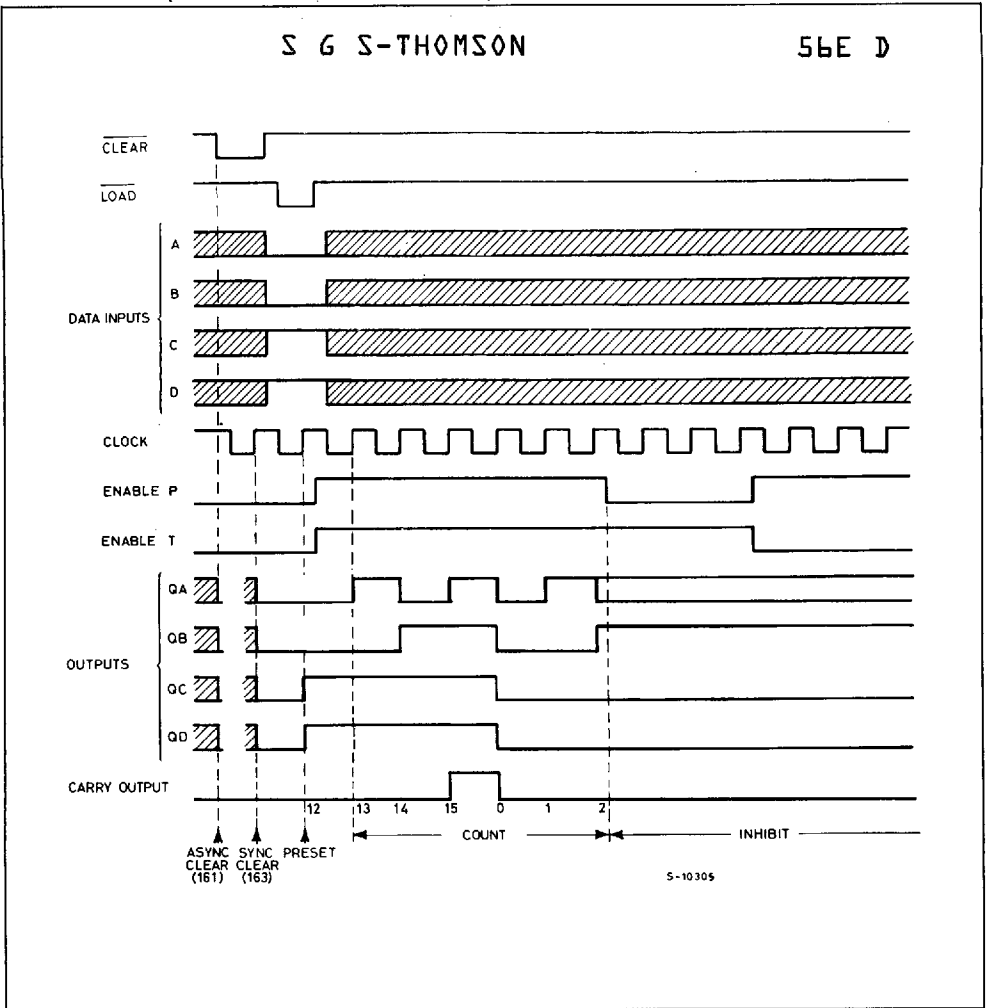

LOGIC DIAGRAM

S G S-THOMSON

56E

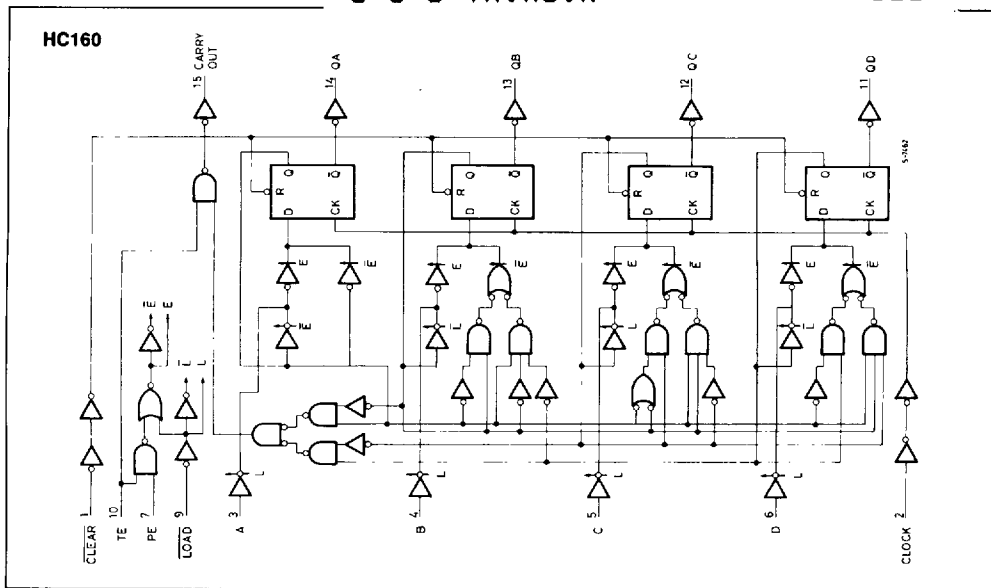

LOGIC DIAGRAM

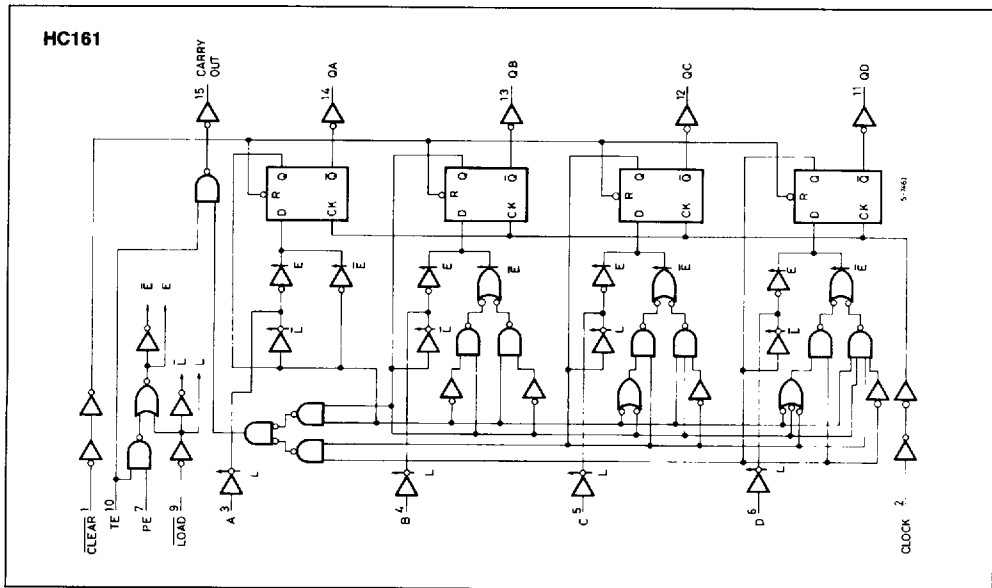

LOGIC DIAGRAM

S G S-THOMSON

56E D

HC162

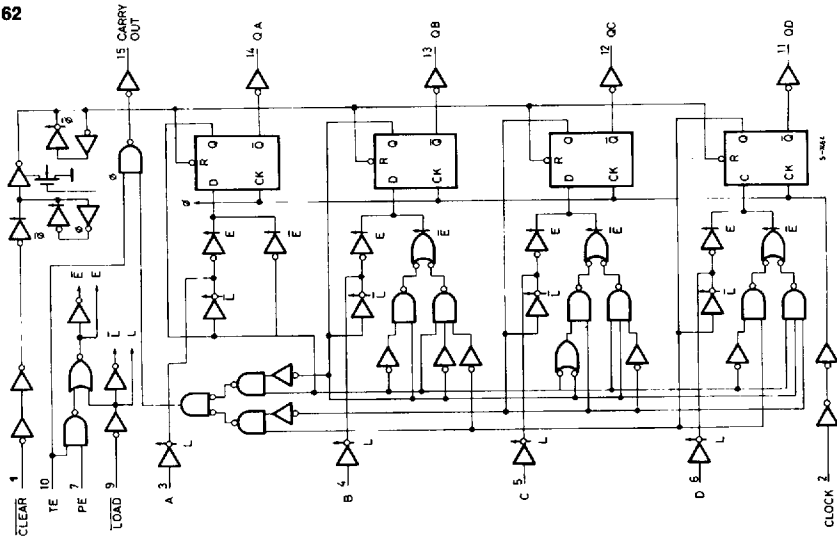

LOGIC DIAGRAM

HC163

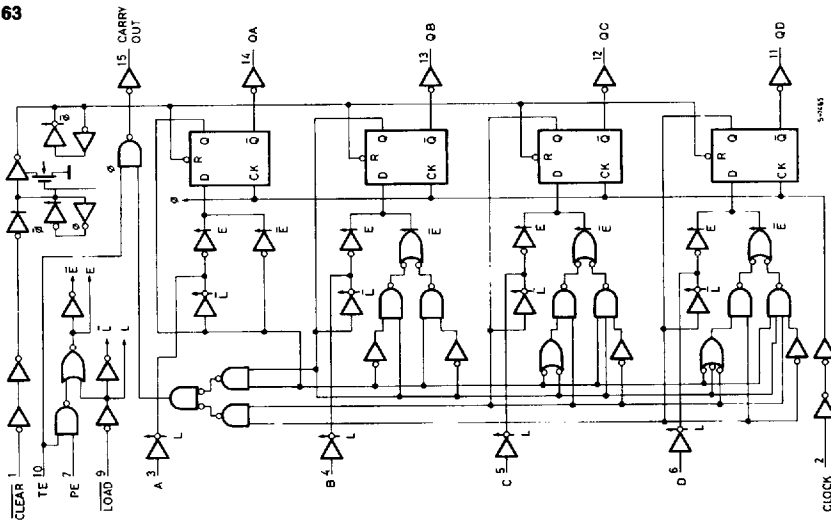

S G S-THOMSON

56E D

## ABSOLUTE MAXIMUM RATINGS

Symbol	Parameter	Value	Unit
$V_{CC}$	Supply Voltage	-0.5 to 7	V
$V_I$	DC Input Voltage	-0.5 to $V_{CC} + 0.5$	V
$V_O$	DC Output Voltage	-0.5 to $V_{CC} + 0.5$	V
$I_{IK}$	DC Input Diode Current	$\pm 20$	mA
$I_{OK}$	DC Output Diode Current	$\pm 20$	mA
$I_O$	DC Output Source Sink Current Per Output Pin	$\pm 25$	mA
$I_{CC}$ or $I_{GND}$	DC $V_{CC}$ or Ground Current	$\pm 50$	mA
$P_D$	Power Dissipation	500 (*)	mW
$T_{stg}$	Storage Temperature	-65 to 150	$^{\circ}C$

Absolute Maximum Ratings are those values beyond which damage to the device may occur. Functional operation under these condition is not implied.

(\*) 500 mW:  $\cong 65^{\circ}C$  derate to 300 mW by 10 mW/ $^{\circ}C$ :  $65^{\circ}C$  to  $85^{\circ}C$ .

## RECOMMENDED OPERATING CONDITIONS

Symbol	Parameter	Value	Unit	
$V_{CC}$	Supply Voltage	2 to 6	V	
$V_I$	Input Voltage	0 to $V_{CC}$	V	
$V_O$	Output Voltage	0 to $V_{CC}$	V	
$T_A$	Operating Temperature	74HC Series 54HC Series	-40 to 85 -55 to 125	$^{\circ}C$
$t_r, t_f$	Input Rise and Fall Time	$V_{CC}$ $\left\{ \begin{array}{l} 2 \text{ V} \\ 4.5 \text{ V} \\ 6 \text{ V} \end{array} \right.$	0 to 1000 0 to 500 0 to 400	ns

## INPUT AND OUTPUT EQUIVALENT CIRCUIT

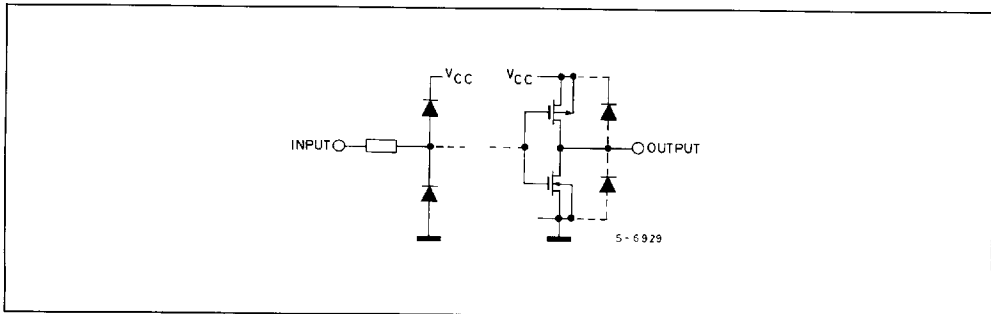

## DC ELECTRICAL CHARACTERISTICS

Symbol	Parameter	V <sub>CC</sub>	Test Condition	T <sub>A</sub> = 25°C 54HC and 74HC			-40 to 85°C 74HC		-55 to 125°C 54HC		Unit	
				Min.	Typ.	Max.	Min.	Max.	Min.	Max.		
V <sub>IH</sub>	High Level Input Voltage	2.0 4.5 6.0		1.5 3.15 4.2	— — —	— — —	1.5 3.15 4.2	— — —	1.5 3.15 4.2	— — —	V	
V <sub>IL</sub>	Low Level Input Voltage	2.0 4.5 6.0		— — —	— — —	0.5 1.35 1.8	— — —	0.5 1.35 1.8	— — —	0.5 1.35 1.8	V	
V <sub>OH</sub>	High Level Output Voltage	2.0	V <sub>I</sub>	I <sub>O</sub>	1.9	2.0	—	1.9	—	1.9	—	V
		4.5	V <sub>IH</sub> or V <sub>IL</sub>	-20 μA	4.4	4.5	—	4.4	—	4.4	—	
		6.0		-4.0 mA	5.9	6.0	—	5.9	—	5.9	—	
		4.5 6.0		-5.2 mA	4.18 5.68	4.31 5.8	— —	4.13 5.63	— —	4.10 5.60	— —	
V <sub>OL</sub>	Low Level Output Voltage	2.0	V <sub>IH</sub> or V <sub>IL</sub>	20 μA	—	0.0	0.1	—	0.1	—	0.1	V
		4.5		—	0.0	0.1	—	0.1	—	0.1	—	
		6.0		—	0.0	0.1	—	0.1	—	0.1	—	
		4.5 6.0		4.0 mA 5.2 mA	— —	0.17 0.18	0.26 0.26	— —	0.33 0.33	— —	0.40 0.40	
I <sub>I</sub>	Input Leakage Current	6.0	V <sub>I</sub> = V <sub>CC</sub> or GND	—	—	±0.1	—	±1.0	—	±1.0	μA	
I <sub>CC</sub>	Quiescent Supply Current	6.0	V <sub>I</sub> = V <sub>CC</sub> or GND	—	—	4	—	40	—	80	μA	

AC ELECTRICAL CHARACTERISTICS (V<sub>CC</sub> = 5V, T<sub>A</sub> = 25°C, C<sub>L</sub> = 15pF, Input t<sub>r</sub> = t<sub>f</sub> = 6ns)

Symbol	Parameter	54HC and 74HC			Unit
		Min.	Typ.	Max.	
t <sub>TLH</sub> t <sub>THL</sub>	Output Transition Time		4	8	ns
t <sub>PLH</sub> t <sub>PHL</sub>	Propagation Delay Time (CLOCK-Q)		18	28	ns
t <sub>PHL</sub> t <sub>PHL</sub>	Propagation Delay Time (CLOCK-CARRY)		22	35	ns
t <sub>PLH</sub> t <sub>PHH</sub>	Propagation Delay Time (TE-CARRY)		10	17	ns
t <sub>PHL</sub>	Propagation Delay (CLEAR-Q)*		21	33	ns
t <sub>PHL</sub>	Propagation Delay time (CLEAR-CARRY)		23	37	ns
f <sub>MAX</sub>	Maximum Clock Frequency	30	50		MHz

S G S-THOMSON

56E D

AC ELECTRICAL CHARACTERISTICS ( $C_L = 50\text{pF}$ , Input  $t_r = t_f = 6\text{ns}$ )

Symbol	Parameter	$V_{CC}$	Test Condition	$T_A = 25^\circ\text{C}$ 54HC and 74HC			$-40$ to $85^\circ\text{C}$ 74HC		$-55$ to $125^\circ\text{C}$ 54HC		Unit
				Min.	Typ.	Max.	Min.	Max.	Min.	Max.	
$t_{TLH}$ $t_{THL}$	Output Transition Time	2.0 4.5 6.0		— — —	30 8 7	75 15 13	— — —	95 19 16	— — —	110 22 19	ns
$t_{PLH}$ $t_{PHL}$	Propagation Delay Time (CLOCK - Q)	2.0 4.5 6.0		— — —	88 22 19	165 33 28	— — —	205 41 35	— — —	250 50 43	ns
$t_{PLH}$ $t_{PHL}$	Propagation Delay Time (CLOCK-CARRY)	2.0 4.5 6.0		— — —	104 26 22	200 40 34	— — —	250 50 43	— — —	300 60 51	ns
$t_{PLH}$ $t_{PHL}$	Propagation Delay Time (TE-CARRY)	2.0 4.5 6.0		— — —	52 13 11	100 20 17	— — —	125 25 21	— — —	150 30 26	ns
$t_{PHL}$	Propagation Delay Time ( $\overline{\text{CLEAR}}-Q$ )•	2.0 4.5 6.0		— — —	100 25 21	185 37 31	— — —	230 46 39	— — —	280 56 48	ns
$t_{PHL}$	Propagation Delay Time ( $\overline{\text{CLEAR}}-CARRY$ )•	2.0 4.5 6.0		— — —	112 28 24	210 42 36	— — —	265 53 45	— — —	315 63 54	ns
$f_{MAX}$	Maximum Clock Frequency	2.0 4.5 6.0		5.4 27 32	11 45 53	— — —	4.4 22 26	— — —	3.5 18 21	— — —	MHz
$t_{W(H)}$ $t_{W(L)}$	Minimum Pulse Width (CLOCK)	2.0 4.5 6.0		— — —	30 8 7	75 15 13	— — —	95 19 16	— — —	110 22 19	ns
$t_{W(L)}$	Minimum Pulse Width ( $\overline{\text{CLEAR}}$ )•	2.0 4.5 6.0		— — —	30 8 7	75 15 13	— — —	95 19 16	— — —	110 22 19	ns
$t_s$	Minimum Set-up Time (LOAD PE, TE)	2.0 4.5 6.0		— — —	50 13 11	125 25 21	— — —	155 31 26	— — —	190 38 22	ns
$t_s$	Minimum Set-up Time (A,B,C,D)	2.0 4.5 6.0		— — —	30 8 7	75 15 13	— — —	95 19 16	— — —	110 22 19	ns
$t_s$	Minimum Set-up Time ( $\overline{\text{CLEAR}}$ )••	2.0 4.5 6.0		— — —	35 9 7	75 15 13	— — —	95 19 16	— — —	110 22 19	ns
$t_h$	Minimum Hold Time	2.0 4.5 6.0		— — —	— — —	0 0 0	— — —	0 0 0	0 0 0	0 0 0	ns



AC ELECTRICAL CHARACTERISTICS (Continued)

Symbol	Parameter	V <sub>CC</sub>	Test Condition	T <sub>A</sub> = 25°C 54HC and 74HC			- 40 to 85°C 74HC		- 55 to 125°C 54HC		Unit
				Min.	Typ.	Max.	Min.	Max.	Min.	Max.	
t <sub>REM</sub>	Minimum Time (CLEAR)*	2.0		—	5	50	—	65	—	75	ns
		4.5		—	1	10	—	13	—	15	
		6.0		—	1	9	—	11	—	13	
C <sub>IN</sub>	Input Capacitance			—	5	7.5	—	7.5	—	—	pF
C <sub>PD</sub> (*)	Power Dissipation Capacitance			—	57	—	—	—	—	—	pF

Note (\*) C<sub>PD</sub> is defined as the value of the IC's internal equivalent capacitance which is calculated from the operating current consumption without load. Average operating current can be obtained by the following equation.

I<sub>CC</sub> (Opr) = C<sub>PD</sub> · V<sub>CC</sub> · f<sub>IN</sub> + I<sub>CC</sub>      •: for M54/74HC160/161 only      ••: for M54/74HC162/163 only

SGS-THOMSON

5BE D

SWITCHING CHARACTERISTICS TEST WAVEFORM

COUNT MODE

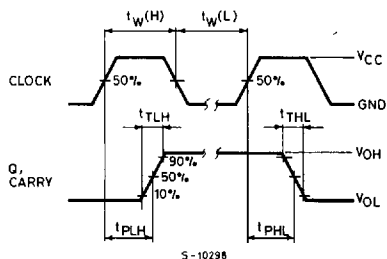

CLEAR MODE (HC160/161)

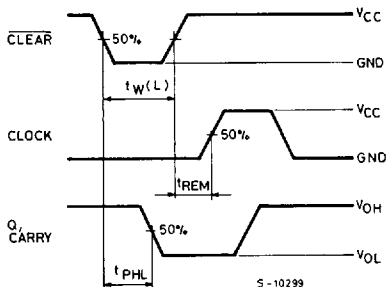

PRESET MODE

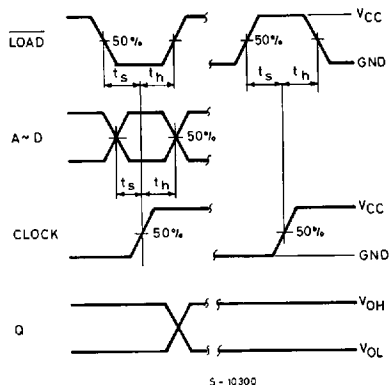

CLEAR MODE (HC162/163)

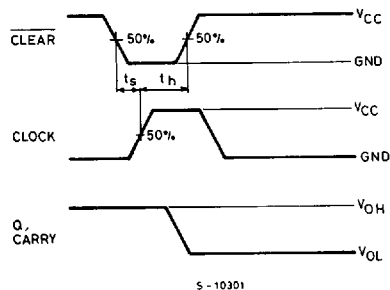

SWITCHING CHARACTERISTICS TEST WAVEFORM (Continued)

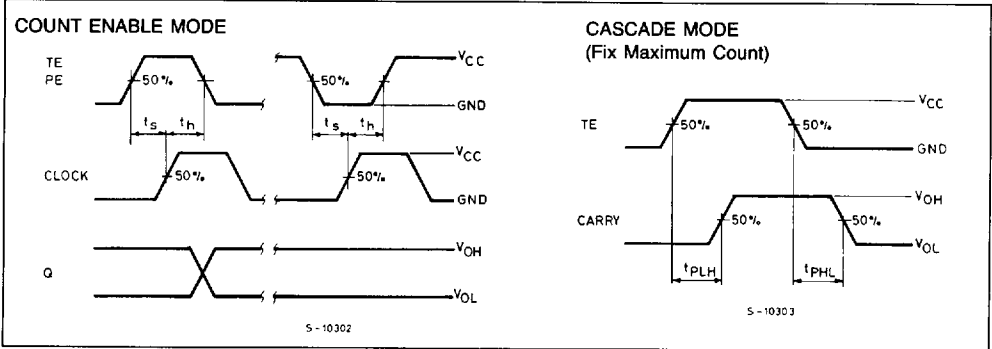

TEST CIRCUIT I<sub>CC</sub> (Opr.)

TOTAL OPERATING CURRENT WHEN USING A CAPACITIVE LOAD

When the outputs drive a capacitive load, the total current can be calculated as follows:  
For M74HC160/162:

$$\Delta I_{CC} = f_{CK} \cdot V_{CC} \cdot \left( \frac{C_a}{2} + \frac{C_b}{5} + \frac{C_c}{10} + \frac{C_d}{10} + \frac{C_{ca}}{10} \right)$$

For M74HC161/163

$$\Delta I_{CC} = f_{CK} \cdot V_{CC} \cdot \left( \frac{C_a}{2} + \frac{C_b}{4} + \frac{C_c}{8} + \frac{C_d}{16} + \frac{C_{ca}}{16} \right)$$

C<sub>a</sub> to C<sub>ca</sub> are the capacitors loading the outputs.

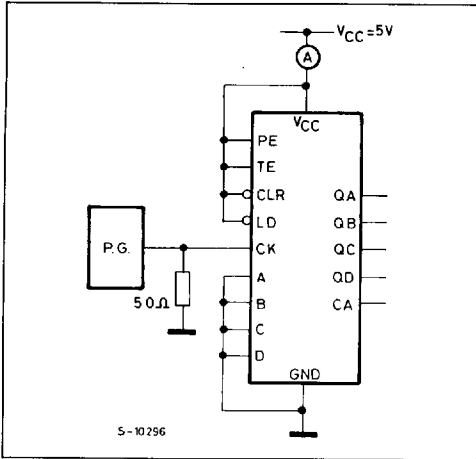

TYPICAL APPLICATION

