



512 Kbit (64Kb x8) UV EPROM and OTP EPROM

- 5V ± 10% SUPPLY VOLTAGE in READ OPERATION
- FAST ACCESS TIME: 45ns
- LOW POWER "CMOS" CONSUMPTION:
 - Active Current 30mA
 - Standby Current 100µA
- PROGRAMMING VOLTAGE: 12.75V ± 0.25V
- PROGRAMMING TIMES of AROUND 6sec. (PRESTO IIB ALGORITHM)
- ELECTRONIC SIGNATURE
 - Manufacturer Code: 20h
 - Device Code: 3Dh

DESCRIPTION

The M27C512 is a 512 Kbit EPROM offered in the two ranges UV (ultra violet erase) and OTP (one time programmable). It is ideally suited for applications where fast turn-around and pattern experimentation are important requirements and is organized as 65,536 by 8 bits.

The FDIP28W (window ceramic frit-seal package) has transparent lid which allows the user to expose the chip to ultraviolet light to erase the bit pattern. A new pattern can then be written to the device by following the programming procedure.

For applications where the content is programmed only one time and erasure is not required, the M27C512 is offered in PDIP28, PLCC32 and TSOP28 (8 x 13.4 mm) packages.

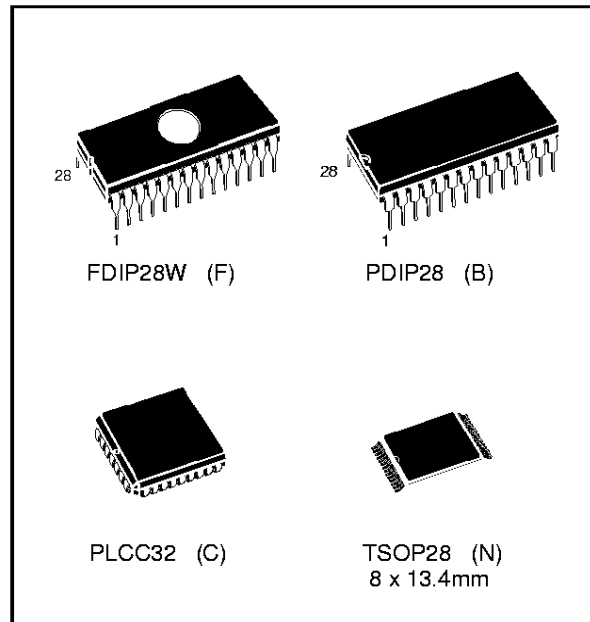

Figure 1. Logic Diagram

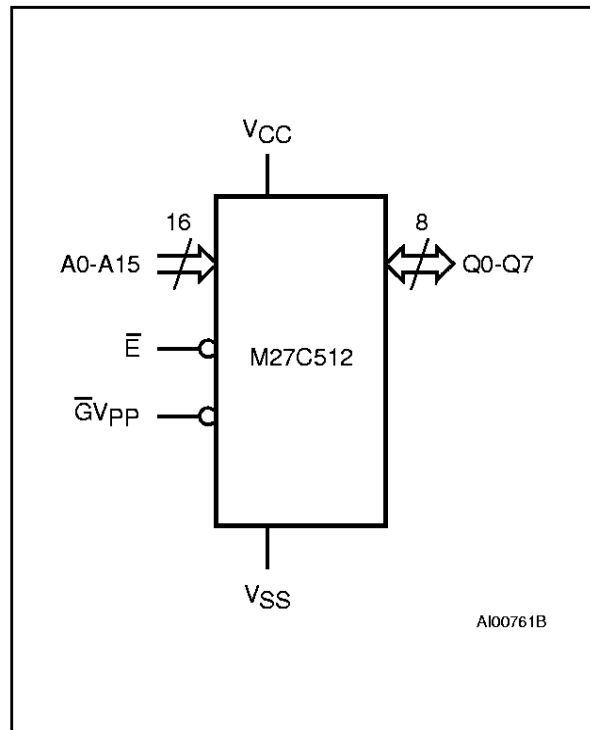

Table 1. Signal Names

A0-A15	Address Inputs
Q0-Q7	Data Outputs
\bar{E}	Chip Enable
$\bar{G}V_{PP}$	Output Enable / Program Supply
V_{CC}	Supply Voltage
V_{SS}	Ground

M27C512

Figure 2A. DIP Pin Connections

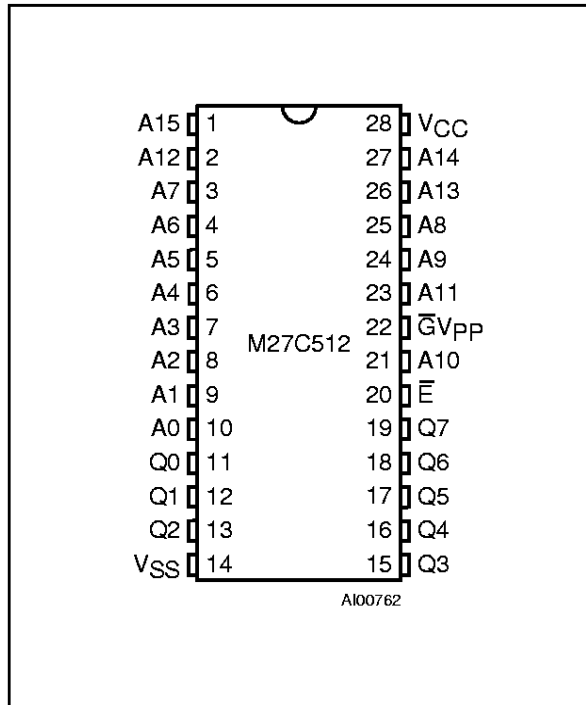
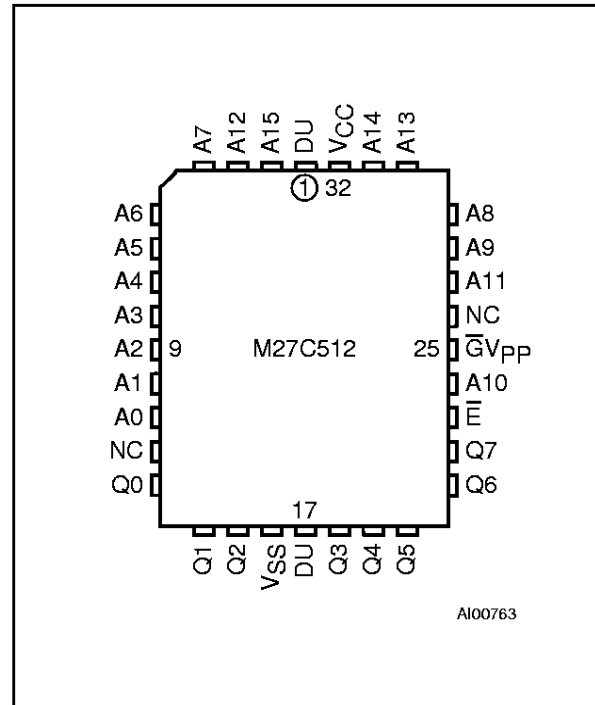
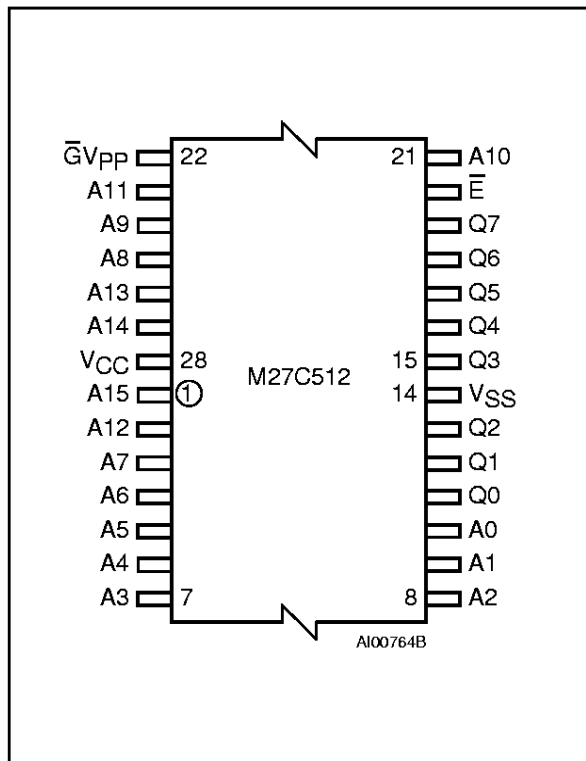

Figure 2B. LCC Pin Connections



Warning: NC = Not Connected, DU = Don't Use

Figure 2C. TSOP Pin Connections



DEVICE OPERATION

The modes of operations of the M27C512 are listed in the Operating Modes table. A single power supply is required in the read mode. All inputs are TTL levels except for \overline{GVPP} and 12V on A9 for Electronic Signature.

Read Mode

The M27C512 has two control functions, both of which must be logically active in order to obtain data at the outputs. Chip Enable (\overline{E}) is the power control and should be used for device selection. Output Enable (\overline{G}) is the output control and should be used to gate data to the output pins, independent of device selection. Assuming that the addresses are stable, the address access time (t_{AVQV}) is equal to the delay from \overline{E} to output (t_{ELQV}). Data is available at the output after a delay of t_{GLQV} from the falling edge of \overline{G} , assuming that \overline{E} has been low and the addresses have been stable for at least $t_{AVQV} - t_{GLQV}$.

Standby Mode

The M27C512 has a standby mode which reduces the active current from 30mA to 100µA. The M27C512 is placed in the standby mode by applying a CMOS high signal to the \overline{E} input. When in the standby mode, the outputs are in a high impedance state, independent of the \overline{GVPP} input.

Table 2. Absolute Maximum Ratings ⁽¹⁾

Symbol	Parameter	Value	Unit
T _A	Ambient Operating Temperature ⁽³⁾	-40 to 125	°C
T _{BIAS}	Temperature Under Bias	-50 to 125	°C
T _{STG}	Storage Temperature	-65 to 150	°C
V _{IO} ⁽²⁾	Input or Output Voltages (except A9)	-2 to 7	V
V _{CC}	Supply Voltage	-2 to 7	V
V _{A9} ⁽²⁾	A9 Voltage	-2 to 13.5	V
V _{PP}	Program Supply Voltage	-2 to 14	V

Notes: 1. Except for the rating "Operating Temperature Range", stresses above those listed in the Table "Absolute Maximum Ratings" may cause permanent damage to the device. These are stress ratings only and operation of the device at these or any other conditions above those indicated in the Operating sections of this specification is not implied. Exposure to Absolute Maximum Rating conditions for extended periods may affect device reliability. Refer also to the STMicroelectronics SURE Program and other relevant quality documents.

2. Minimum DC voltage on Input or Output is -0.5V with possible undershoot to -2.0V for a period less than 20ns. Maximum DC voltage on Output is V_{CC} +0.5V with possible overshoot to V_{CC} +2V for a period less than 20ns.

3. Depends on range.

Table 3. Operating Modes

Mode	\bar{E}	$\bar{G}V_{PP}$	A9	Q0 - Q7
Read	V _{IL}	V _{IL}	X	Data Out
Output Disable	V _{IL}	V _{IH}	X	Hi-Z
Program	V _{IL} Pulse	V _{PP}	X	Data In
Program Inhibit	V _{IH}	V _{PP}	X	Hi-Z
Standby	V _{IH}	X	X	Hi-Z
Electronic Signature	V _{IL}	V _{IL}	V _{ID}	Codes

Note: X = V_{IH} or V_{IL}, V_{ID} = 12V ± 0.5V

Table 4. Electronic Signature

Identifier	A0	Q7	Q6	Q5	Q4	Q3	Q2	Q1	Q0	Hex Data
Manufacturer's Code	V _{IL}	0	0	1	0	0	0	0	0	20h
Device Code	V _{IH}	0	0	1	1	1	1	0	1	3Dh

Two Line Output Control

Because EPROMs are usually used in larger memory arrays, the product features a 2 line control function which accommodates the use of multiple memory connection. The two line control function allows:

- the lowest possible memory power dissipation,
- complete assurance that output bus contention will not occur.

For the most efficient use of these two control lines, \bar{E} should be decoded and used as the primary device selecting function, while \bar{G} should be made a common connection to all devices in the array and connected to the \overline{READ} line from the system control bus. This ensures that all deselected memory devices are in their low power standby mode and that the output pins are only active when data is required from a particular memory device.

Table 5. AC Measurement Conditions

	High Speed	Standard
Input Rise and Fall Times	≤ 10ns	≤ 20ns
Input Pulse Voltages	0 to 3V	0.4V to 2.4V
Input and Output Timing Ref. Voltages	1.5V	0.8V and 2V

Figure 3. AC Testing Input Output Waveform

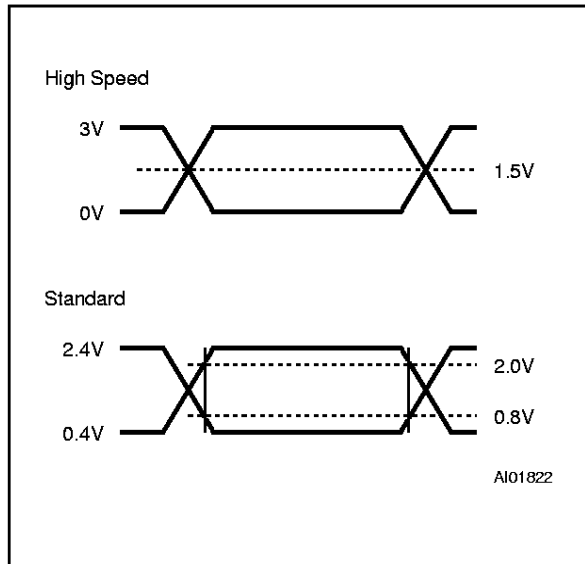

Figure 4. AC Testing Load Circuit

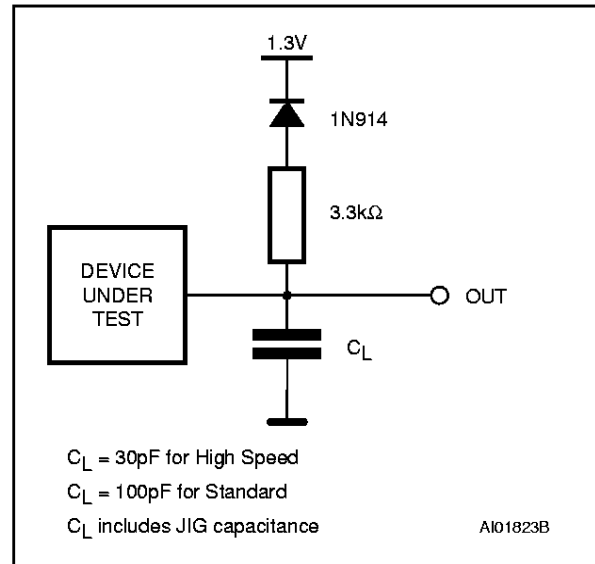

Table 6. Capacitance ⁽¹⁾ (T_A = 25 °C, f = 1 MHz)

Symbol	Parameter	Test Condition	Min	Max	Unit
C _{IN}	Input Capacitance	V _{IN} = 0V		6	pF
C _{OUT}	Output Capacitance	V _{OUT} = 0V		12	pF

Note. 1. Sampled only, not 100% tested.

System Considerations

The power switching characteristics of Advanced CMOS EPROMs require careful decoupling of the devices. The supply current, I_{CC}, has three segments that are of interest to the system designer: the standby current level, the active current level, and transient current peaks that are produced by the falling and rising edges of \bar{E} . The magnitude of the transient current peaks is dependent on the capacitive and inductive loading of the device at the output.

The associated transient voltage peaks can be suppressed by complying with the two line output control and by properly selected decoupling capacitors. It is recommended that a 0.1μF ceramic capacitor be used on every device between V_{CC} and V_{SS}. This should be a high frequency capacitor of low inherent inductance and should be placed as close to the device as possible. In addition, a 4.7μF bulk electrolytic capacitor should be used between V_{CC} and V_{SS} for every eight devices. The bulk capacitor should be located near the power supply connection point. The purpose of the bulk capacitor is to overcome the voltage drop caused by the inductive effects of PCB traces.

Table 7. Read Mode DC Characteristics ⁽¹⁾(T_A = 0 to 70 °C, -40 to 85 °C or -40 to 125 °C; V_{CC} = 5V ± 5% or 5V ± 10%; V_{PP} = V_{CC})

Symbol	Parameter	Test Condition	Min	Max	Unit
I _{LI}	Input Leakage Current	0V ≤ V _{IN} ≤ V _{CC}		±10	μA
I _{LO}	Output Leakage Current	0V ≤ V _{OUT} ≤ V _{CC}		±10	μA
I _{CC}	Supply Current	$\bar{E} = V_{IL}, \bar{G} = V_{IL},$ I _{OUT} = 0mA, f = 5MHz		30	mA
I _{CC1}	Supply Current (Standby) TTL	$\bar{E} = V_{IH}$		1	mA
I _{CC2}	Supply Current (Standby) CMOS	$\bar{E} > V_{CC} - 0.2V$		100	μA
I _{PP}	Program Current	V _{PP} = V _{CC}		10	μA
V _{IL}	Input Low Voltage		-0.3	0.8	V
V _{IH} ⁽²⁾	Input High Voltage		2	V _{CC} + 1	V
V _{OL}	Output Low Voltage	I _{OL} = 2.1mA		0.4	V
V _{OH}	Output High Voltage TTL	I _{OH} = -1mA	3.6		V
	Output High Voltage CMOS	I _{OH} = -100μA	V _{CC} - 0.7V		V

Notes: 1. V_{CC} must be applied simultaneously with or before V_{PP} and removed simultaneously or after V_{PP}.2. Maximum DC voltage on Output is V_{CC} + 0.5V.**Table 8A. Read Mode AC Characteristics ⁽¹⁾**(T_A = 0 to 70 °C, -40 to 85 °C or -40 to 125 °C; V_{CC} = 5V ± 5% or 5V ± 10%; V_{PP} = V_{CC})

Symbol	Alt	Parameter	Test Condition	M27C512								Unit
				-45 ⁽³⁾		-60		-70		-80		
				Min	Max	Min	Max	Min	Max	Min	Max	
t _{AVQV}	t _{ACC}	Address Valid to Output Valid	$\bar{E} = V_{IL}, \bar{G} = V_{IL}$		45		60		70		80	ns
t _{ELQV}	t _{CE}	Chip Enable Low to Output Valid	$\bar{G} = V_{IL}$		45		60		70		80	ns
t _{GLQV}	t _{OE}	Output Enable Low to Output Valid	$\bar{E} = V_{IL}$		25		30		35		40	ns
t _{EHQZ} ⁽²⁾	t _{DF}	Chip Enable High to Output Hi-Z	$\bar{G} = V_{IL}$	0	25	0	25	0	30	0	30	ns
t _{GHQZ} ⁽²⁾	t _{DF}	Output Enable High to Output Hi-Z	$\bar{E} = V_{IL}$	0	25	0	25	0	30	0	30	ns
t _{AXQX}	t _{OH}	Address Transition to Output Transition	$\bar{E} = V_{IL}, \bar{G} = V_{IL}$	0		0		0		0		ns

Notes: 1. V_{CC} must be applied simultaneously with or before V_{PP} and removed simultaneously or after V_{PP}.

2. Sampled only, not 100% tested.

3. In case of 45ns speed see High Speed AC measurement conditions.

Table 8B. Read Mode AC Characteristics (1)

(TA = 0 to 70 °C, -40 to 85 °C or -40 to 125 °C; VCC = 5V ± 5% or 5V ± 10%; VPP = VCC)

Symbol	Alt	Parameter	Test Condition	M27C512								Unit
				-90		-10		-12		-15/-20/-25		
				Min	Max	Min	Max	Min	Max	Min	Max	
tAVQV	tACC	Address Valid to Output Valid	$\bar{E} = V_{IL}, \bar{G} = V_{IL}$		90		100		120		150	ns
tELQV	tCE	Chip Enable Low to Output Valid	$\bar{G} = V_{IL}$		90		100		120		150	ns
tGLQV	tOE	Output Enable Low to Output Valid	$\bar{E} = V_{IL}$		40		40		50		60	ns
tEHQZ (2)	tDF	Chip Enable High to Output Hi-Z	$\bar{G} = V_{IL}$	0	30	0	30	0	40	0	50	ns
tGHQZ (2)	tDF	Output Enable High to Output Hi-Z	$\bar{E} = V_{IL}$	0	30	0	30	0	40	0	50	ns
tAXQX	tOH	Address Transition to Output Transition	$\bar{E} = V_{IL}, \bar{G} = V_{IL}$	0		0		0		0		ns

Notes. 1. VCC must be applied simultaneously with or before VPP and removed simultaneously or after VPP.

2. Sampled only, not 100% tested.

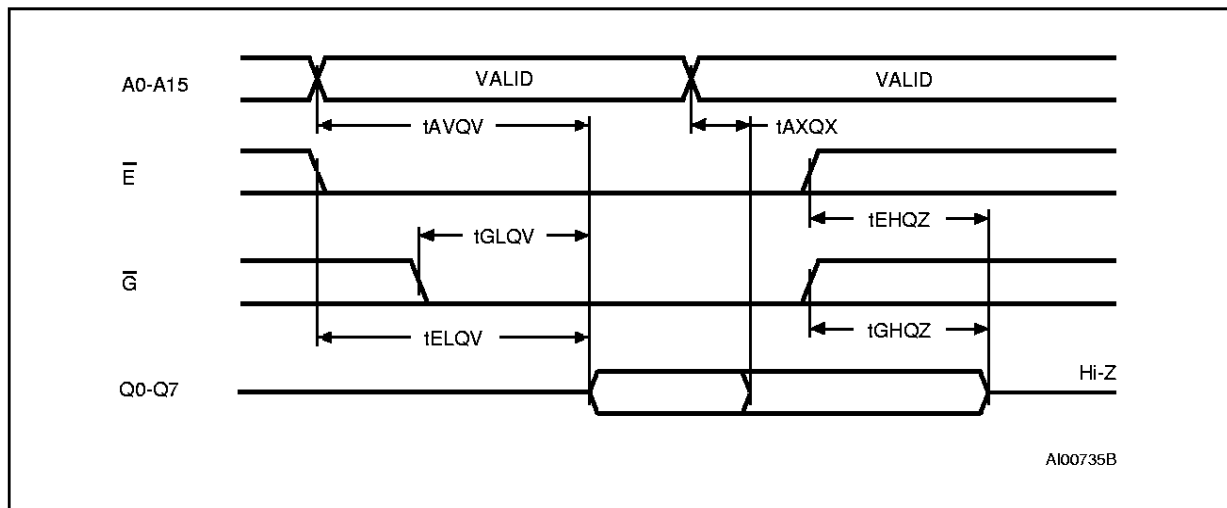
Figure 5. Read Mode AC Waveforms**Programming**

When delivered (and after each erasure for UV EPROM), all bits of the M27C512 are in the '1' state. Data is introduced by selectively programming '0's into the desired bit locations. Although only '0's will be programmed, both '1's and '0's can be present in the data word. The only way to change a '0' to a '1' is by die exposure to ultraviolet light (UV EPROM). The M27C512 is in the programming mode when VPP input is at 12.75V and

\bar{E} is pulsed to V_{IL} . The data to be programmed is applied to 8 bits in parallel to the data output pins. The levels required for the address and data inputs are TTL. VCC is specified to be 6.25V ± 0.25V.

The M27C512 can use PRESTO IIB Programming Algorithm that drastically reduces the programming time (typically less than 6 seconds). Nevertheless to achieve compatibility with all programming equipments, PRESTO Programming Algorithm can be used as well.

Table 9. Programming Mode DC Characteristics ⁽¹⁾(T_A = 25 °C; V_{CC} = 6.25V ± 0.25V; V_{PP} = 12.75V ± 0.25V)

Symbol	Parameter	Test Condition	Min	Max	Unit
I _{LI}	Input Leakage Current	V _{IL} ≤ V _{IN} ≤ V _{IH}		±10	μA
I _{CC}	Supply Current			50	mA
I _{PP}	Program Current	$\bar{E} = V_{IL}$		50	mA
V _{IL}	Input Low Voltage		-0.3	0.8	V
V _{IH}	Input High Voltage		2	V _{CC} + 0.5	V
V _{OL}	Output Low Voltage	I _{OL} = 2.1 mA		0.4	V
V _{OH}	Output High Voltage TTL	I _{OH} = -1 mA	3.6		V
V _{ID}	A9 Voltage		11.5	12.5	V

Note: 1. V_{CC} must be applied simultaneously with or before V_{PP} and removed simultaneously or after V_{PP}.**Table 10. MARGIN MODE AC Characteristics ⁽¹⁾**(T_A = 25 °C; V_{CC} = 6.25V ± 0.25V; V_{PP} = 12.75V ± 0.25V)

Symbol	Alt	Parameter	Test Condition	Min	Max	Unit
t _{A9HVPH}	t _{AS9}	VA9 High to V _{PP} High		2		μs
t _{VPHEL}	t _{VPS}	V _{PP} High to Chip Enable Low		2		μs
t _{A10HEH}	t _{AS10}	VA10 High to Chip Enable High (Set)		1		μs
t _{A10LEH}	t _{AS10}	VA10 Low to Chip Enable High (Reset)		1		μs
t _{EXA10X}	t _{AH10}	Chip Enable Transition to VA10 Transition		1		μs
t _{EXVPX}	t _{VPH}	Chip Enable Transition to V _{PP} Transition		2		μs
t _{VPPXA9X}	t _{AH9}	V _{PP} Transition to VA9 Transition		2		μs

Note: 1. V_{CC} must be applied simultaneously with or before V_{PP} and removed simultaneously or after V_{PP}.**Table 11. Programming Mode AC Characteristics ⁽¹⁾**(T_A = 25 °C; V_{CC} = 6.25V ± 0.25V; V_{PP} = 12.75V ± 0.25V)

Symbol	Alt	Parameter	Test Condition	Min	Max	Unit
t _{AVEL}	t _{AS}	Address Valid to Chip Enable Low		2		μs
t _{QVEL}	t _{DS}	Input Valid to Chip Enable Low		2		μs
t _{VCHL}	t _{VCS}	V _{CC} High to Chip Enable Low		2		μs
t _{VPHEL}	t _{OES}	V _{PP} High to Chip Enable Low		2		μs
t _{VPLVPH}	t _{PRT}	V _{PP} Rise Time		50		ns
t _{ELEH}	t _{PW}	Chip Enable Program Pulse Width (Initial)		95	105	μs
t _{EHQX}	t _{DH}	Chip Enable High to Input Transition		2		μs
t _{EHVPX}	t _{OEH}	Chip Enable High to V _{PP} Transition		2		μs
t _{VPLEL}	t _{VR}	V _{PP} Low to Chip Enable Low		2		μs
t _{ELOV}	t _{DV}	Chip Enable Low to Output Valid			1	μs
t _{EHQZ} ⁽²⁾	t _{DFP}	Chip Enable High to Output Hi-Z		0	130	ns
t _{EHAX}	t _{AH}	Chip Enable High to Address Transition		0		ns

Notes: 1. V_{CC} must be applied simultaneously with or before V_{PP} and removed simultaneously or after V_{PP}.

2. Sampled only, not 100% tested.

Figure 6. MARGIN MODE AC Waveforms

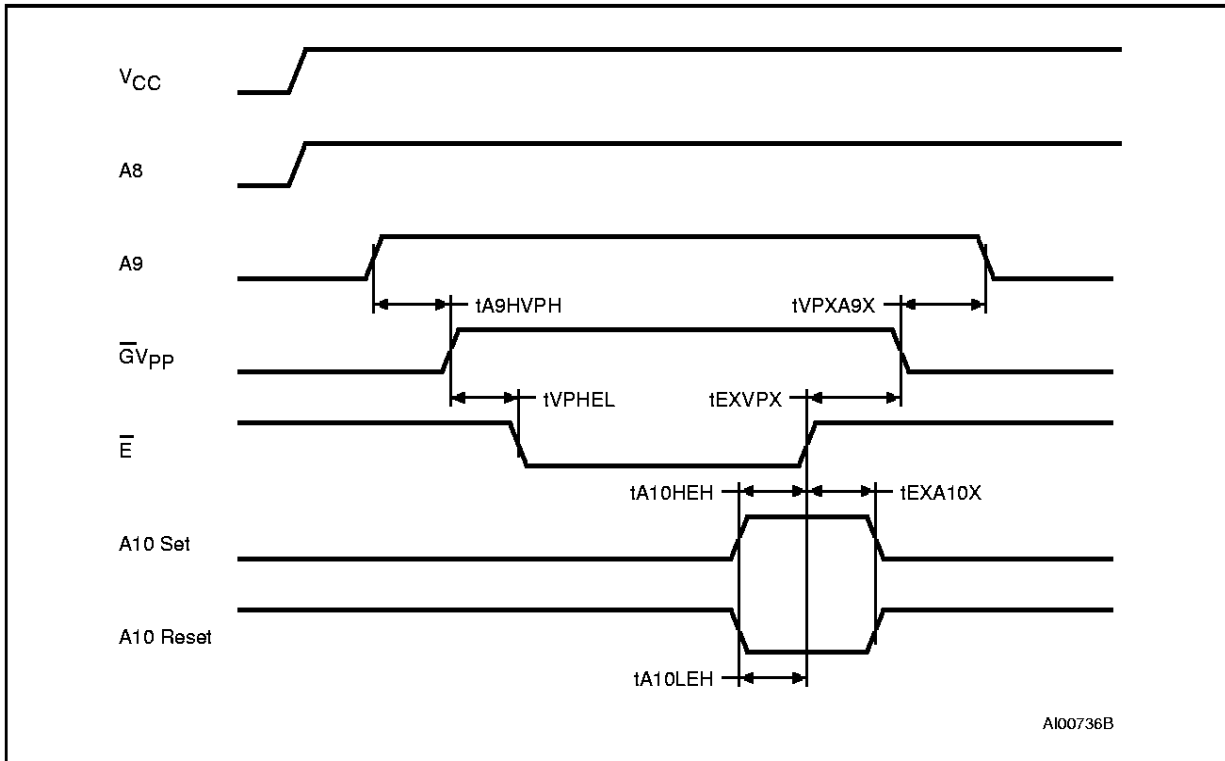

Note: A_8 High level = 5V; A_9 High level = 12V.

Figure 7. Programming and Verify Modes AC Waveforms

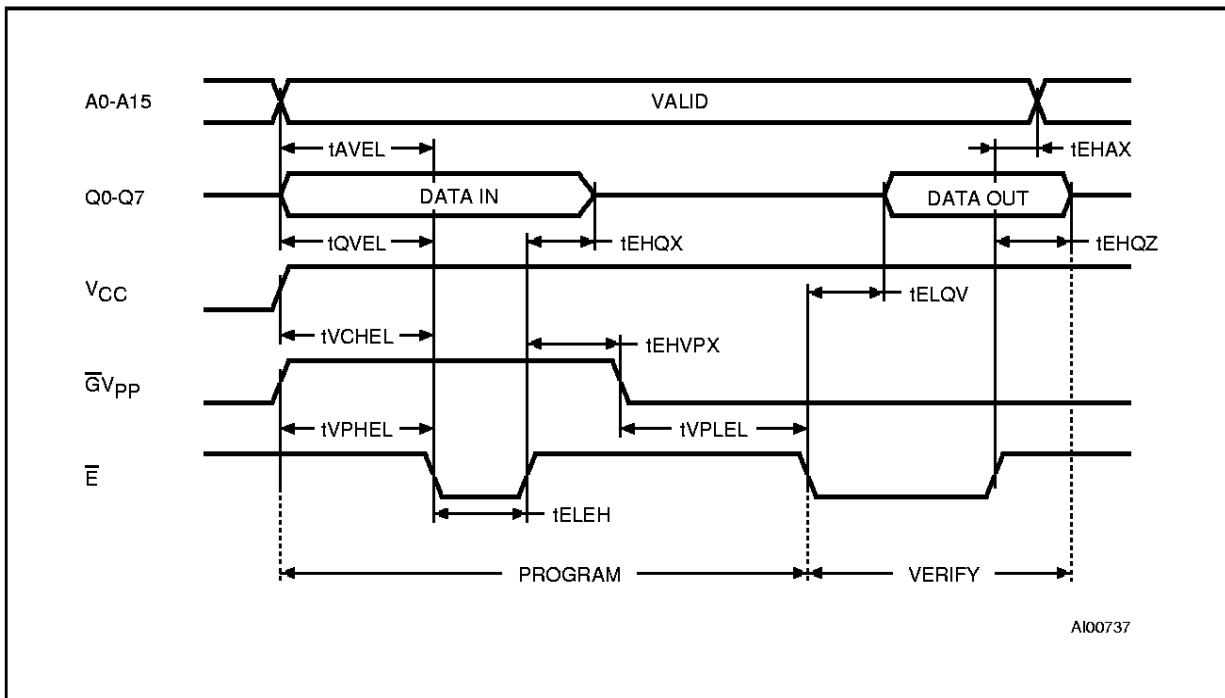
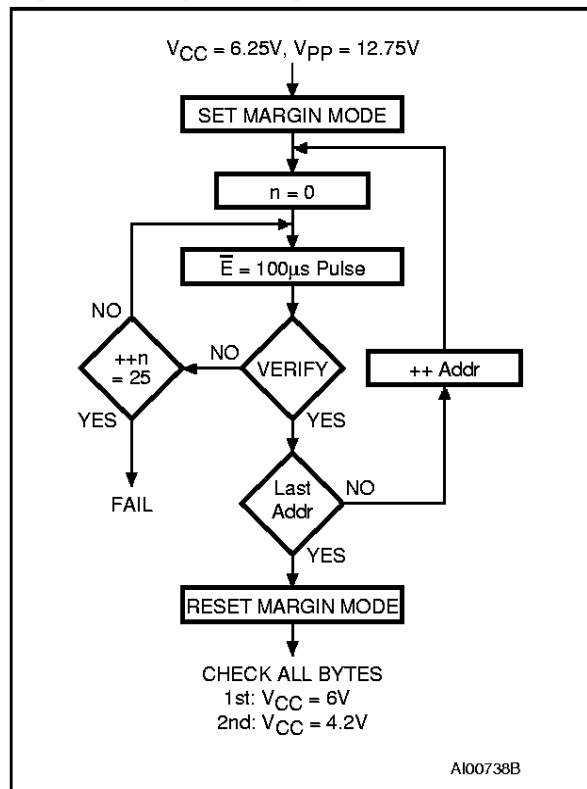

Figure 8. Programming Flowchart



programmed. The verify is accomplished with \overline{G} at V_{IL} . Data should be verified with t_{ELQV} after the falling edge of \overline{E} .

On-Board Programming

The M27C512 can be directly programmed in the application circuit. See the relevant Application Note AN620.

Electronic Signature

The Electronic Signature (ES) mode allows the reading out of a binary code from an EPROM that will identify its manufacturer and type. This mode is intended for use by programming equipment to automatically match the device to be programmed with its corresponding programming algorithm. The ES mode is functional in the $25^{\circ}\text{C} \pm 5^{\circ}\text{C}$ ambient temperature range that is required when programming the M27C512. To activate the ES mode, the programming equipment must force 11.5V to 12.5V on address line A9 of the M27C512. Two identifier bytes may then be sequenced from the device outputs by toggling address line A0 from V_{IL} to V_{IH} . All other address lines must be held at V_{IL} during Electronic Signature mode.

Byte 0 ($A0=V_{IL}$) represents the manufacturer code and byte 1 ($A0=V_{IH}$) the device identifier code. For the STMicroelectronics M27C512, these two identifier bytes are given in Table 4 and can be read-out on outputs Q0 to Q7.

PRESTO IIB Programming Algorithm

PRESTO IIB Programming Algorithm allows the whole array to be programmed with a guaranteed margin, in a typical time of 6.5 seconds. This can be achieved with STMicroelectronics M27C512 due to several design innovations described in the M27C512 datasheet to improve programming efficiency and to provide adequate margin for reliability. Before starting the programming the internal MARGIN MODE circuit is set in order to guarantee that each cell is programmed with enough margin. Then a sequence of $100\mu\text{s}$ program pulses are applied to each byte until a correct verify occurs. No overprogram pulses are applied since the verify in MARGIN MODE provides the necessary margin.

Program Inhibit

Programming of multiple M27C512s in parallel with different data is also easily accomplished. Except for \overline{E} , all like inputs including $\overline{G}V_{PP}$ of the parallel M27C512 may be common. A TTL low level pulse applied to a M27C512's \overline{E} input, with V_{PP} at 12.75V, will program that M27C512. A high level \overline{E} input inhibits the other M27C512s from being programmed.

Program Verify

A verify (read) should be performed on the programmed bits to determine that they were correctly

ERASURE OPERATION (applies for UV EPROM)

The erasure characteristics of the M27C512 is such that erasure begins when the cells are exposed to light with wavelengths shorter than approximately 4000 \AA . It should be noted that sunlight and some type of fluorescent lamps have wavelengths in the $3000\text{-}4000\text{ \AA}$ range.

Research shows that constant exposure to room level fluorescent lighting could erase a typical M27C512 in about 3 years, while it would take approximately 1 week to cause erasure when exposed to direct sunlight. If the M27C512 is to be exposed to these types of lighting conditions for extended periods of time, it is suggested that opaque labels be put over the M27C512 window to prevent unintentional erasure. The recommended erasure procedure for the M27C512 is exposure to short wave ultraviolet light which has wavelength 2537 \AA . The integrated dose (i.e. UV intensity x exposure time) for erasure should be a minimum of 15 W-sec/cm^2 . The erasure time with this dosage is approximately 15 to 20 minutes using an ultraviolet lamp with $12000\text{ }\mu\text{W/cm}^2$ power rating. The M27C512 should be placed within 2.5 cm (1 inch) of the lamp tubes during the erasure. Some lamps have a filter on their tubes which should be removed before erasure.

ORDERING INFORMATION SCHEME

Example: M27C512 -70 X C 1 TR

Speed		V _{CC} Tolerance		Package		Temperature Range		Option	
-45 ⁽¹⁾	45 ns	X	± 5%	F	FDIP28W	1	0 to 70 °C	X	Additional Burn-in
-60	60 ns	blank	± 10%	B	PDIP28	6	-40 to 85 °C		
-70	70 ns			C	PLCC32	3	-40 to 125 °C	TR	Tape & Reel Packing
-80	80 ns			N	TSOP28 8 x 13.4mm				
-90	90 ns								
-10	100 ns								
-12	120 ns								
-15	150 ns								
-20	200 ns								
-25	250 ns								

Note: 1. High Speed, see AC Characteristics section for further information

For a list of available options (Speed, V_{CC} Tolerance, Package, etc...) or for further information on any aspect of this device, please contact the STMicroelectronics Sales Office nearest to you.

FDIP28W - 28 pin Ceramic Frit-seal DIP, with window

Symb	mm			inches		
	Typ	Min	Max	Typ	Min	Max
A			5.72			0.225
A1		0.51	1.40		0.020	0.055
A2		3.91	4.57		0.154	0.180
A3		3.89	4.50		0.153	0.177
B		0.41	0.56		0.016	0.022
B1	1.45	–	–	0.057	–	–
C		0.23	0.30		0.009	0.012
D		36.50	37.34		1.437	1.470
D2	33.02	–	–	1.300	–	–
E	15.24	–	–	0.600	–	–
E1		13.06	13.36		0.514	0.526
e	2.54	–	–	0.100	–	–
eA	14.99	–	–	0.590	–	–
eB		16.18	18.03		0.637	0.710
L		3.18			0.125	
S		1.52	2.49		0.060	0.098
∅	7.11	–	–	0.280	–	–
α		4°	11°		4°	11°
N		28			28	

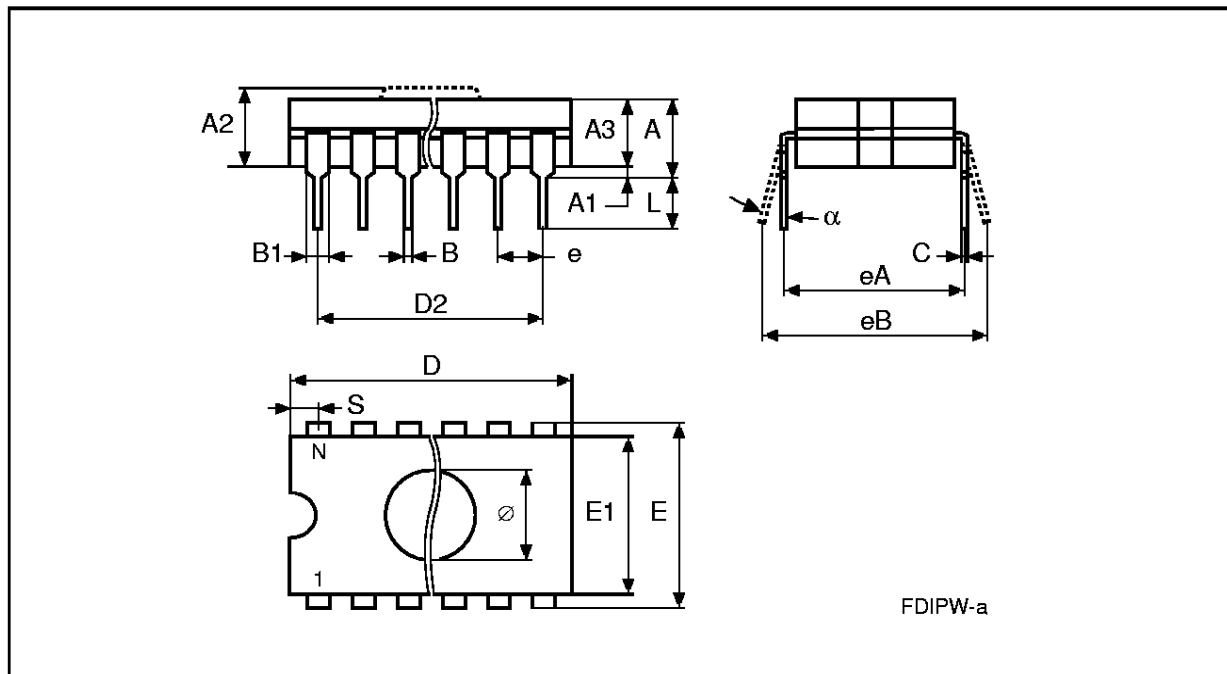

Drawing is not to scale

PDIP28 - 28 pin Plastic DIP, 600 mils width

Symb	mm			inches		
	Typ	Min	Max	Typ	Min	Max
A		–	5.08		–	0.200
A1		0.38	–		0.015	–
A2		3.56	4.06		0.140	0.160
B		0.38	0.51		0.015	0.020
B1	1.52	–	–	0.060	–	–
C		0.20	0.30		0.008	0.012
D		36.83	37.34		1.450	1.470
D2	33.02	–	–	1.300	–	–
E	15.24	–	–	0.600	–	–
E1		13.59	13.84		0.535	0.545
e1	2.54	–	–	0.100	–	–
eA	14.99	–	–	0.590	–	–
eB		15.24	17.78		0.600	0.700
L		3.18	3.43		0.125	0.135
S		1.78	2.08		0.070	0.082
α		0°	10°		0°	10°
N		28			28	

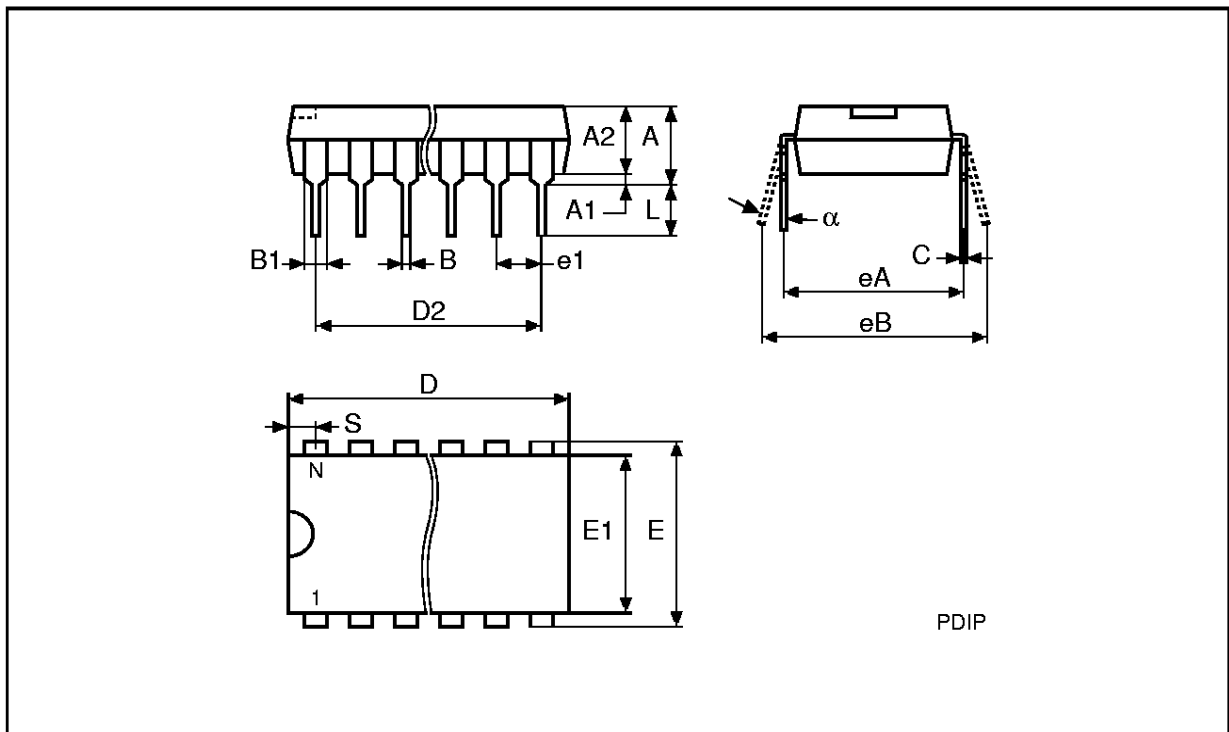

Drawing is not to scale

PLCC32 - 32 lead Plastic Leaded Chip Carrier, rectangular

Symb	mm			inches		
	Typ	Min	Max	Typ	Min	Max
A		2.54	3.56		0.100	0.140
A1		1.52	2.41		0.060	0.095
A2		–	0.38		–	0.015
B		0.33	0.53		0.013	0.021
B1		0.66	0.81		0.026	0.032
D		12.32	12.57		0.485	0.495
D1		11.35	11.56		0.447	0.455
D2		9.91	10.92		0.390	0.430
E		14.86	15.11		0.585	0.595
E1		13.89	14.10		0.547	0.555
E2		12.45	13.46		0.490	0.530
e	1.27	–	–	0.050	–	–
F		0.00	0.25		0.000	0.010
R	0.89	–	–	0.035	–	–
N		32			32	
Nd		7			7	
Ne		9			9	
CP			0.10			0.004

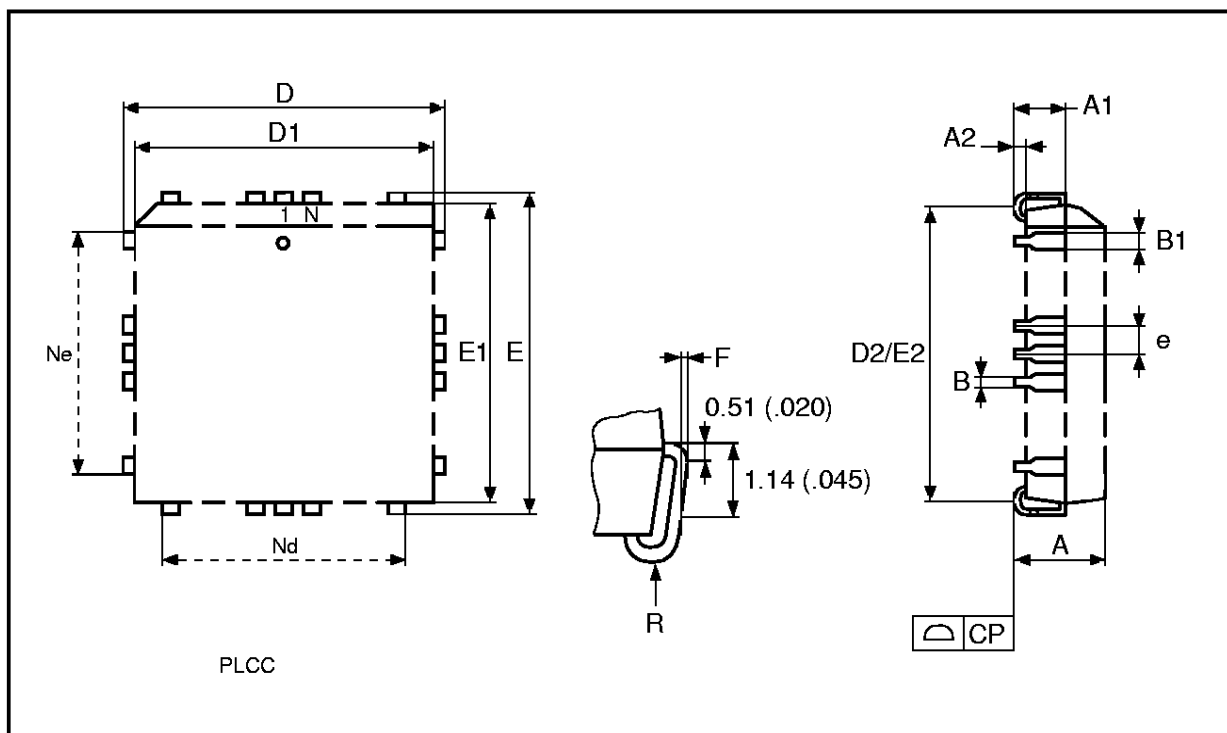

Drawing is not to scale

TSOP28 - 28 lead Plastic Thin Small Outline, 8 x 13.4mm

Symb	mm			inches		
	Typ	Min	Max	Typ	Min	Max
A			1.25			0.049
A1			0.20			0.008
A2		0.95	1.15		0.037	0.045
B		0.17	0.27		0.007	0.011
C		0.10	0.21		0.004	0.008
D		13.20	13.60		0.520	0.535
D1		11.70	11.90		0.461	0.469
E		7.90	8.10		0.311	0.319
e	0.55	-	-	0.022	-	-
L		0.50	0.70		0.020	0.028
α		0°	5°		0°	5°
N	28			28		
CP			0.10			0.004

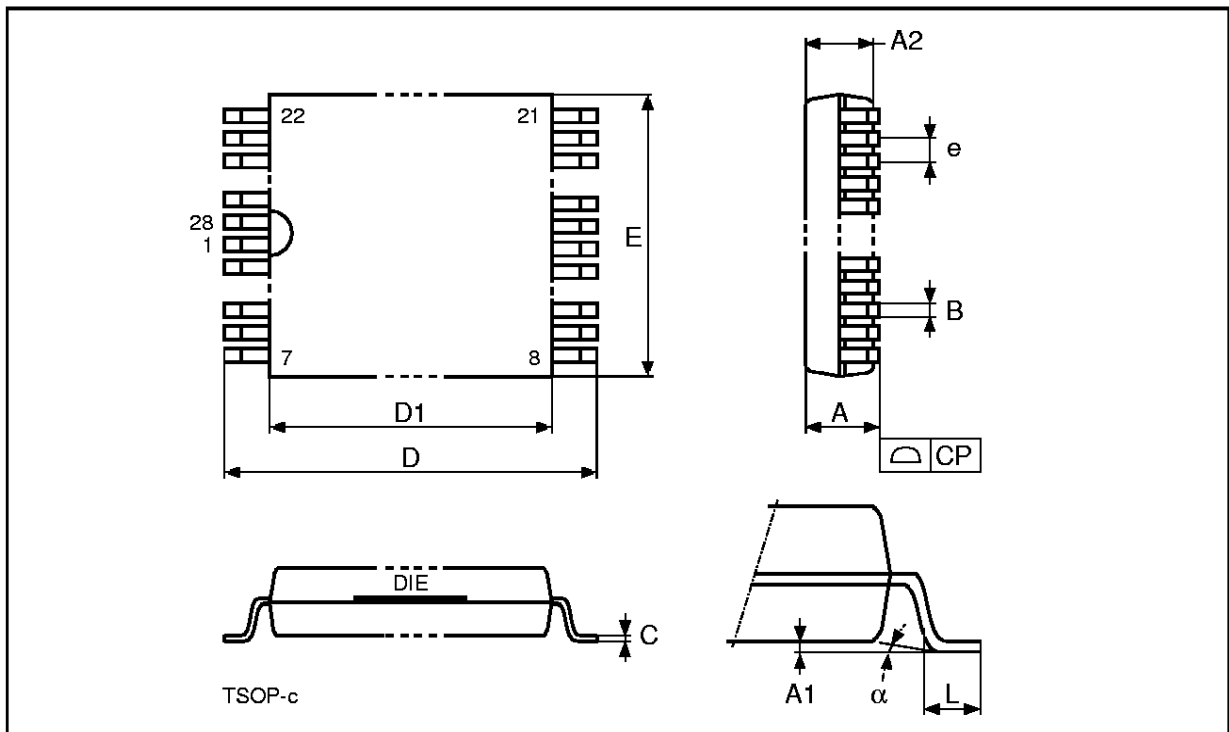

Drawing is not to scale

Information furnished is believed to be accurate and reliable. However, STMicroelectronics assumes no responsibility for the consequences of use of such information nor for any infringement of patents or other rights of third parties which may result from its use. No license is granted by implication or otherwise under any patent or patent rights of STMicroelectronics. Specifications mentioned in this publication are subject to change without notice. This publication supersedes and replaces all information previously supplied. STMicroelectronics products are not authorized for use as critical components in life support devices or systems without express written approval of STMicroelectronics.

The ST logo is a registered trademark of STMicroelectronics

© 1998 STMicroelectronics - All Rights Reserved

STMicroelectronics GROUP OF COMPANIES

Australia - Brazil - Canada - China - France - Germany - Italy - Japan - Korea - Malaysia - Malta - Morocco - The Netherlands -
Singapore - Spain - Sweden - Switzerland - Taiwan - Thailand - United Kingdom - U.S.A.

<http://www.st.com>