

PRODUCT NO.

XXXXX-YYTFLF

LEAD FREE OPTION  
SEE NOTE 11 AND 12

TUBE PACKAGING (SEE NOTE 8)

NO. OF POSITIONS (SEE NOTE 6)

PLATING NUMBER  
(SEE SHEETS 2 & 3 FOR PIN P/N)

BASE PART NO.  
(SEE SHT 3)

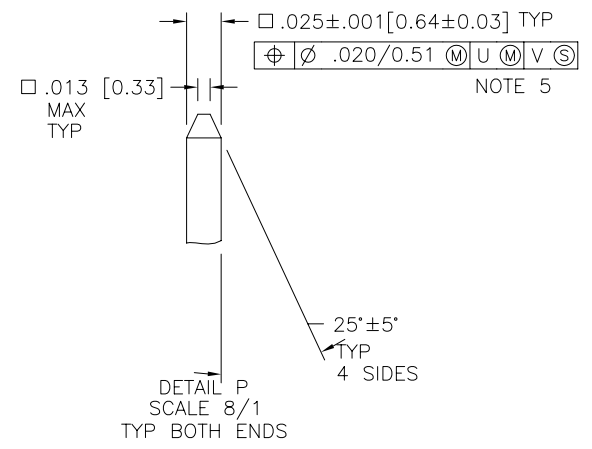
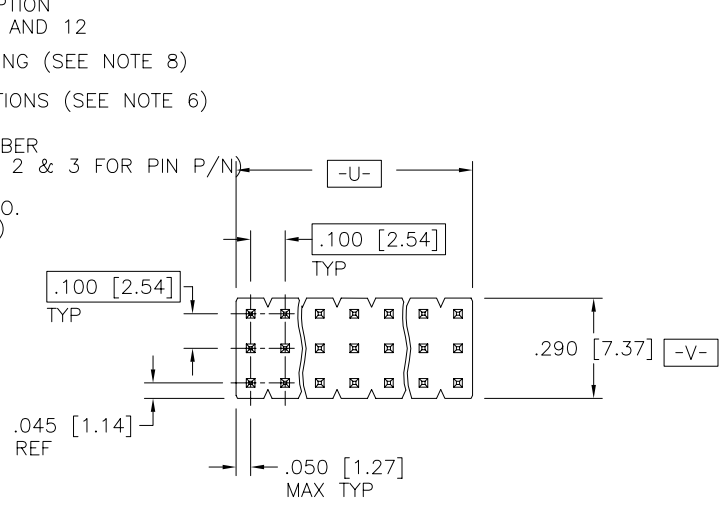

MATING LENGTH  
DIM H  
NOTE 9

TOTAL PIN LENGTH  
DIM F ±.010 [0.25]

POS#2  
POS#1

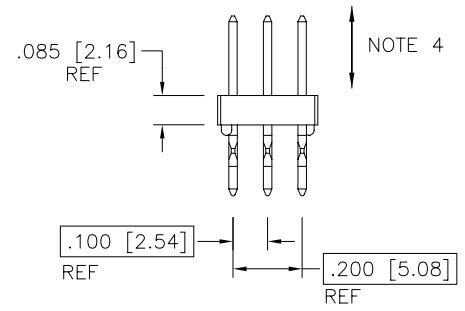
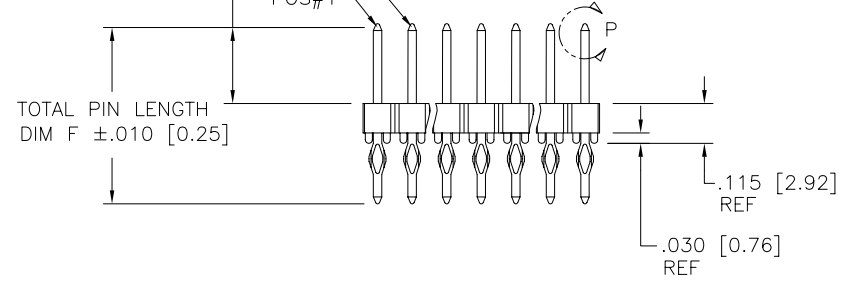

FCIconnect.com

Copyright FCI

mat'l. code				surface ISO 1302 ✓		tolerance ISO 406 ISO 1101		projection INCH/MM		product family BERGSTIK			
ltr				ecn no		dr		date		tolerances unless otherwise specified		title	
A				V50617		HTB		5/31/95		angles		BERGSTIK® II HDR. T/R	
B				V51033		LSS		9/01/95		linear		.XX±.01/.3	
C				V82179		EPK		12/18/98		0°±2'		.xxx±.005/.13	
D				V20832		GIP		7/16/		dr		.xxxx±.0020/.051	
E				M05-0118		ERE		6/02/05		enr		M. CLOUSER 9/20/94	
F				M06-0271		AGS		7/15/06		chr		T. HANNA 9/20/94	
										appd		T. HANNA 9/31/94	
sheet index		revision sheet		F 1		F 2		F 3					



form: A3

PLATING NUMBER	CONTACT AREA "DIM D" PLATING	PRESS FIT TAIL PLATING
XXXXX-1YY	30u"/0.76u Au OVER 50u"/1.27u Ni	40u"/1.02u TIN-LEAD OVER 50u"/1.27u Ni
XXXXX-2YY	15u"/0.38u Au OVER 50u"/1.27u Ni.	40u"/1.02u TIN-LEAD OVER 50u"/1.27u Ni.
XXXXX-4YY	120u"/3.05u TIN-LEAD OVER 50u"/1.27u Ni.	120u"/3.05u TIN-LEAD OVER 50u"/1.27u Ni.
LF PLATING NUMBER	CONTACT AREA "DIM D" PLATING	PRESS FIT TAIL PLATING
XXXXX-1YYLF	30u"/0.76u Au OVER 50u"/1.27u Ni	40u"/1.02u TIN OVER 50u"/1.27u Ni
XXXXX-2YYLF	15u"/0.38u Au OVER 50u"/1.27u Ni.	40u"/1.02u TIN OVER 50u"/1.27u Ni.
XXXXX-4YYLF	120u"/3.05u TIN OVER 50u"/1.27u Ni.	120u"/3.05u TIN OVER 50u"/1.27u Ni.

SEE NOTE 13

NOTES:

- ① BODY MATERIAL : GLASS FIBER REINFORCED PCT FLAME RETARDANT PER UL-94V-0. COLOR: BLACK
- ② PIN MATERIAL : PHOS-BRONZE.
- 3. FINISH :  
CONTACT AREA : SEE TABLE  
PRESS FIT TAIL : SEE TABLE
- ④ 2 Lbs / 0.9 Kg MIN PIN RETENTION IN EITHER DIRECTION.
- ⑤ MEASURED WITH PART IN RESTRAINED CONDITION.
- ⑥ ANY NUMBER OF POSITIONS PER ROW FROM 3 (3X3) THROUGH 36 (3X36).
- 7. PACKAGED IN POLYBAGS.
- ⑧ EIGHT-DIGIT PART NUMBERS FOLLOWED BY A "T" ARE PACKAGED IN TUBES. SEE SPECIFIC PART NUMBERS FOR AVAILABILITY.
- ⑨ TO ASSURE PROPER INSTALLATION: BERG TOOLING, AS SPECIFIED IN INSTRUCTION MANUAL 166578 MUST BE USED. PIN MATING LENGTH WILL BE ±.005/0.13 AFTER INSTALLATION.
- ⑩  $\varnothing.0453/1.151$  DRILLED HOLE PLATED WITH  $.0003/.007$  MIN. SnPb OVER  $.001/.03$  TO  $.003/.08$  Cu. PLATING TO ACHIEVE A  $\varnothing.040\pm.003/1.02\pm.08$  HOLE.
- ⑪ ADD "LF" SUFFIX AT THE END OF PART NUMBER FOR LEAD FREE OPTION.
- ⑫ THIS PRODUCT MEETS EUROPEAN UNION DIRECTIVES AND OTHER COUNTRY REGULATION AS DESCRIBED IN GS-22-008.
- ⑬ "THIS PRODUCT HAS 100% TIN PLATING IN THE INTERFACE AND HAS NOT BEEN TESTED FOR WHISKER GROWTH IN ALL INTERCONNECT ENVIRONMENTS."

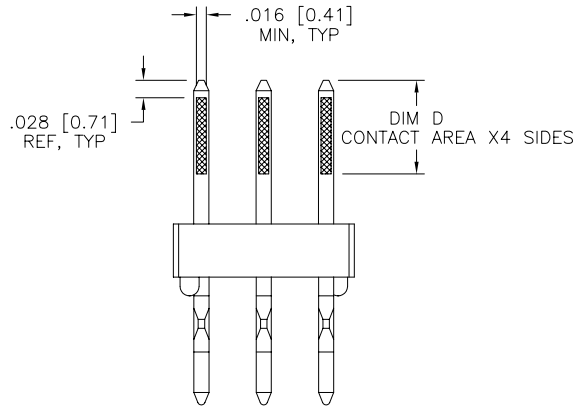

TRIPLE ROW  
END VIEW

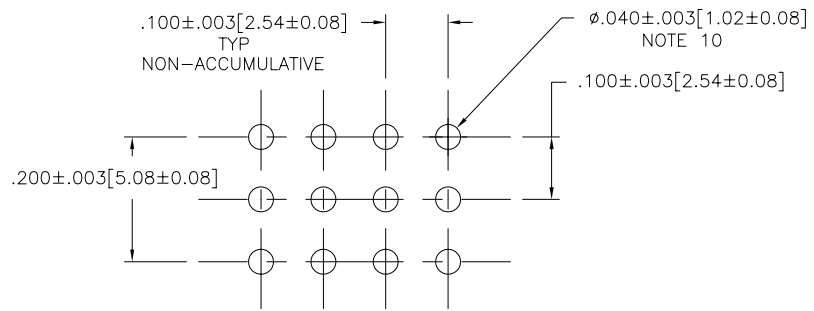

TRIPLE ROW  
RECOMMENDED HOLE PATTERN  
SCALE: 4/1

mat'l. code		surface ISO 1302 ✓	tolerance ISO 406 ISO 1101	projection INCH/MM	product family BERGSTIK
ltr	ecn no	dr	date	tolerances unless otherwise specified	title
F				angles linear 0'±2'	BERGSTIK® II HDR. T/R .100 DUPLEX PRESS FIT
				dr M. CLOUSER 9/20/94 enr T. HANNA 9/20/94 chr T. HANNA 9/20/94 appd T. HANNA 9/31/94	scale 1:1
sheet index		revision sheet			dwg no 95154 sheet 2 of 3 size A3
					type Product Customer Drawing



FCIconnect.com

Copyright FCI

PRODUCT NO.	TOTAL PIN LGTH		MATING LENGTH		CONTACT AREA		PACKAGING
	DIM F	DIM F	DIM H	DIM H	DIM D	DIM D	
	ENGLISH	METRIC	ENGLISH	METRIC	ENGLISH	METRIC	
95154-XYX	0.520	13.21	0.230	5.84	0.185	4.70	POLY BAGS
95155-XYX	0.608	15.44	0.318	8.08	0.200	5.08	POLY BAGS
95154-XYXLF	0.520	13.21	0.230	5.84	0.185	4.70	POLY BAGS
95155-XYXLF	0.608	15.44	0.318	8.08	0.200	5.08	POLY BAGS



Copyright FCI

mat'l. code		surface ISO 1302 <input checked="" type="checkbox"/>		tolerance ISO 406 ISO 1101		projection 		product family BERGSTIK	
ltr	ecn no	dr	date	tolerances unless otherwise specified		INCH/MM		title	
F				angles	linear	.XX±.01/.3 .XXX±.005/.13 .XXXX±.0020/.051		BERGSTIK® II HDR. T/R .100 DUPLEX PRESS FIT	
				0'±2'		scale 1:1		dwg no sheet 3 of 3 size	
				dr	M. CLOUSER	9/20/94		95154 A3	
				enr	T. HANNA	9/20/94			
				chr	T. HANNA	9/20/94			
				appd	T. HANNA	9/31/94		type Product Customer Drawing	
sheet index	revision sheet								