



# OP-80

ULTRA-LOW BIAS CURRENT  
OPERATIONAL AMPLIFIER

Precision Monolithics Inc.

## FEATURES

- **Ultra-Low Bias Current:**
  - 150 femtoamps Typ .....at +25°C
  - 300 femtoamps Typ .....at +85°C
  - 500 femtoamps Typ .....at +125°C
- **True Single Supply Operation**  
Common-Mode Range Includes Ground  
Output Swings to Within 200 $\mu$ V of Ground Without  
Pulldown Resistors
- **Low Supply Current** .....325 $\mu$ A Max
- **Lower Cost Alternative to AD549 and OPA128**
- **Low Cost**
- **Inputs Protected Against 700V of Static Discharge**
- **Available in Die Form**

## APPLICATIONS

- Electrometer Amplifier Input Stage
- Photodiode and Infrared Detector Preamplifier
- Chemical and Gas Analyzers
- pH Probe Buffer Amplifier
- Fire Detectors
- High Voltage Voltmeters
- Charge Amplifiers

## GENERAL DESCRIPTION

The OP-80 is a low cost CMOS operational amplifier offering exceptionally low input currents over a wide operating temperature range. Input current is typically 150 femtoamps at 25°C and increases to only 300 femtoamps at +85°C, with exceptionally

high common-mode and differential input impedances. Incorporating a novel input protection design, the OP-80 achieves over 700V of ESD protection while maintaining very low input current.

For systems demanding both high performance at low supply voltages and high input impedances, the OP-80 is a powerful design tool. It is ideal for use in electrometers, portable medical instrumentation, chemical analyzers, smoke detectors, and sensitive current-to-voltage conversion circuits for photodiodes.

The low supply current minimizes thermal power dissipation, virtually eliminating the effects of chip self-heating. The OP-80's CMOS design gives a good speed/power ratio, permitting a

*Continued*

## PIN CONNECTIONS

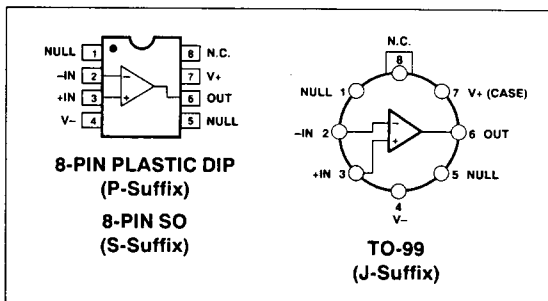

## SIMPLIFIED SCHEMATIC

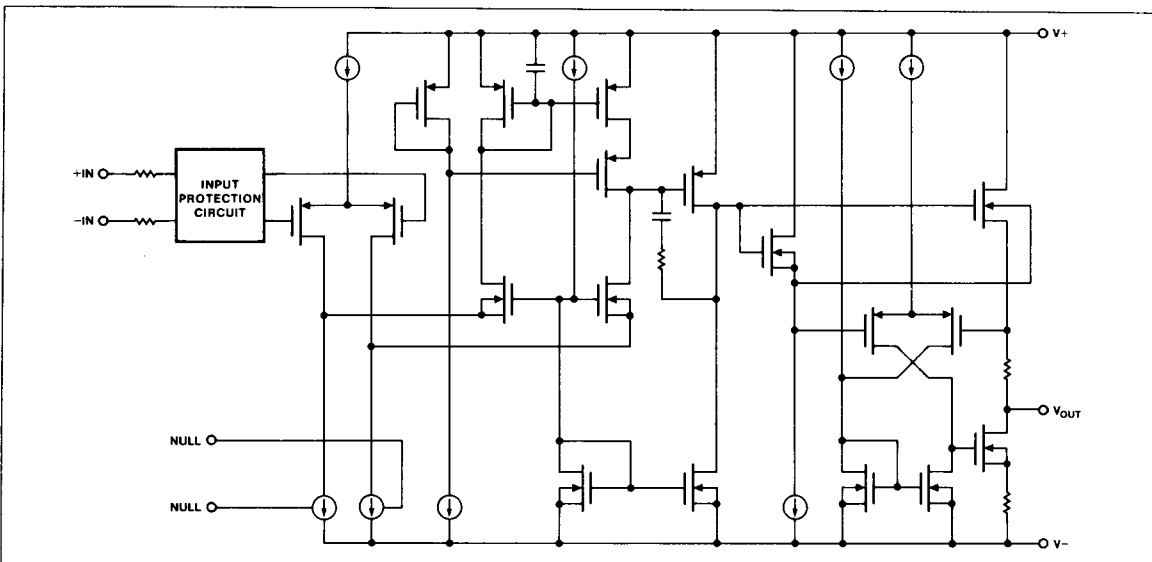

**GENERAL DESCRIPTION** *Continued*

0.2V/ $\mu$ s minimum slew rate and a 300kHz gain-bandwidth product with unity-gain stability.

The OP-80 offers greater than 100dB of gain into a 2k $\Omega$  load, with output source/sink capability exceeding 15mA. In single supply applications, the OP-80's input range and output swing extends to ground. No pull-down resistor is required for the output to actively swing to within 200 $\mu$ V of ground.

Other applications for the OP-80 include precision pH, conductivity and ion measurement systems, low-level light and infrared detectors, barcode readers, and magnetic and electric field detectors. Its exceptional versatility makes it suitable for general-purpose applications, especially those requiring a single +5V supply.

The OP-80 conforms to the industry-standard 741 pinout, with the nulling potentiometer between pins 1 and 5, and the wiper to V-.

**ABSOLUTE MAXIMUM RATINGS** (Note 1)

Supply Voltage .....	$\pm 8V$
Input Voltage (Note 2) .....	+8V, -8.2V
Differential Input Voltage (Note 2) .....	16V
Output Short-Circuit Duration (Note 3) .....	Indefinite
Operating Temperature Range	
OP-80G (P,S) .....	-40°C to +85°C
OP-80E,F,G (J) .....	-40°C to +85°C
OP-80B (J) .....	-55°C to +125°C
Storage Temperature Range .....	-65°C to +175°C
Junction Temperature Range .....	-65°C to +175°C
Lead Temperature (Soldering, 10 sec) .....	300°C

PACKAGE TYPE	$\theta_{JA}$ (Note 4)	$\theta_{JC}$	UNITS
TO-99 (J)	150	18	°C/W
8-Pin Plastic DIP (P)	103	43	°C/W
8-Pin SO (S)	158	43	°C/W

**NOTES:**

- Absolute maximum ratings apply to both DICE and packaged parts, unless otherwise noted.
- For supply voltages less than  $\pm 8V$ , the absolute maximum input voltage is equal to (V+) and (V- - 0.2V).
- The output may be shorted to ground indefinitely, but current must be externally limited to 25mA if the output is shorted to V+.
- $\theta_{JA}$  is specified for worst case mounting conditions, i.e.,  $\theta_{JA}$  is specified for device in socket for TO and P-DIP packages;  $\theta_{JA}$  is specified for device soldered to printed circuit board for SO package.

**ORDERING INFORMATION** †

$I_B$ ( $\mu$ A)	PACKAGE		OPERATING TEMPERATURE RANGE
	TO-99	PLASTIC 8-PIN	
2.0	OP80BJ*	-	MIL
0.250	OP80EJ	-	XIND
1.0	OP80FJ	-	XIND
2.0	-	OP80GP	XIND
2.0	-	OP80GS††	XIND

\* For devices processed in total compliance to MIL-STD-883, add /883 after part number. Consult factory for 883 data sheet.

† Burn-in is available on commercial and industrial temperature range parts in CerDIP, plastic DIP, and TO-can packages. For ordering information, see PMI's Data Book, Section 2.

†† For availability and burn-in information on SO packages, contact your local sales office.

**ELECTRICAL CHARACTERISTICS** at  $V_S = \pm 5V$ ,  $V_{CM} = 0V$ ,  $T_A = +25^\circ C$ .

PARAMETER	SYMBOL	CONDITIONS	MIN	OP-80E		MIN	OP-80F		UNITS
				TYP	MAX		TYP	MAX	
Input Offset Voltage	$V_{OS}$		-	0.2	1.5	-	0.4	1.5	mV
Input Offset Current	$I_{OS}$		-	50	-	-	80	-	$\mu$ A
Input Bias Current	$I_B$		-	0.15	0.250	-	0.2	1.0	$\mu$ A
Input Voltage Range	IVR	Lower Limit	-	(V-0V)	-	-	(V-0V)	-	V
		Upper Limit	-	(V+ - 1.5V)	-	-	(V+ - 1.5V)	-	
Common-Mode Rejection	CMR	$V_{CM} = -4.75V, 3.5V$	50	70	-	50	65	-	dB
Power-Supply Rejection	PSR	$V_S = \pm 2.25V$ to $\pm 8V$	60	80	-	60	76	-	dB
Large-Signal Voltage Gain	$A_{VO}$	$V_O = -4.5V$ to $+3.25V$ , $R_L = 10k\Omega$	100	400	-	100	300	-	V/mV

**ELECTRICAL CHARACTERISTICS** at  $V_S = \pm 5V$ ,  $V_{CM} = 0V$ ,  $T_A = +25^\circ C$ . *Continued*

PARAMETER	SYMBOL	CONDITIONS	OP-80E			OP-80F			UNITS
			MIN	TYP	MAX	MIN	TYP	MAX	
Output Voltage Swing	$V_O$	$V_S = \pm 5V$ , $R_L = 10k\Omega$	+3.5/ -4.75	+3.7/ -4.9	-	+3.5/ -4.75	+3.7/ -4.9	-	V
	$V_{OH}$	$V_+ = +5V$ , $V_- = 0V$ , $R_L = 10k\Omega$	+3.5	+3.7	-	+3.5	+3.7	-	V
	$V_{OL}$	$V_+ = +5V$ , $V_- = 0V$ , $R_L = 10k\Omega$	-	0.2	1	-	0.2	1	mV
Supply Current	$I_{SY}$	No Load	-	200	325	-	200	325	$\mu A$
Input Noise Voltage Density	$e_n$	$f_O = 1000Hz$	-	70	-	-	70	-	$nV/\sqrt{Hz}$
Output Current	$I_{OUT}$	Source Sink	25 15	45 24	- -	25 15	45 24	- -	mA
Slew Rate	SR	$A_V = +1$	0.2	0.4	-	0.2	0.4	-	$V/\mu s$
Gain-Bandwidth Product	GBW		-	300	-	-	300	-	kHz
Input Resistance		Common-Mode	-	$10^{16}$	-	-	$10^{16}$	-	$\Omega$
		Differential	-	$10^{13}$	-	-	$10^{13}$	-	$\Omega$

**ELECTRICAL CHARACTERISTICS** at  $V_S = \pm 5V$ ,  $V_{CM} = 0V$ ,  $T_A = +25^\circ C$ .

PARAMETER	SYMBOL	CONDITIONS	MIN	OP-80B	MAX	UNITS
				TYP		
Input Offset Voltage	$V_{OS}$		-	0.5	2.0	mV
Input Offset Current	$I_{OS}$		-	100	-	fA
Input Bias Current	$I_B$		-	0.6	2.0	pA
Input Voltage Range	IVR	Lower Limit Upper Limit	- -	(V - 0V) (V + -1.5V)	- -	V
Common-Mode Rejection	CMR	$V_{CM} = -4.75V, 3.5V$	50	65	-	dB
Power-Supply Rejection	PSR	$V_S = \pm 2.25V$ to $\pm 8V$	60	76	-	dB
Large-Signal Voltage Gain	$A_{VO}$	$V_O = -4.5V$ to $+3.25V$ , $R_L = 10k\Omega$	100	225	-	$V/mV$
Output Voltage Swing	$V_O$	$V_S = \pm 5V$ , $R_L = 10k\Omega$	+3.5/ -4.75	+3.7/ -4.9	-	V
	$V_{OH}$	$V_+ = +5V$ , $V_- = 0V$ , $R_L = 10k\Omega$	+3.5	+3.7	-	V
	$V_{OL}$	$V_+ = +5V$ , $V_- = 0V$ , $R_L = 10k\Omega$	-	0.2	1	mV
Supply Current	$I_{SY}$	No Load	-	200	325	$\mu A$
Input Noise Voltage Density	$e_n$	$f_O = 1000Hz$	-	70	-	$nV/\sqrt{Hz}$
Output Current	$I_{OUT}$	Source Sink	25 15	45 24	- -	mA
Slew Rate	SR	$A_V = +1$	0.2	0.4	-	$V/\mu s$
Gain-Bandwidth Product	GBW		-	300	-	kHz
Input Resistance		Common-Mode	-	$10^{16}$	-	$\Omega$
		Differential	-	$10^{13}$	-	$\Omega$

**ELECTRICAL CHARACTERISTICS** at  $V_S = \pm 5V$ ,  $V_{CM} = 0V$ ,  $-40^\circ C \leq T_A \leq +85^\circ C$  for E/F grades;  $-55^\circ C \leq T_A \leq +125^\circ C$  for B grade.

PARAMETER	SYMBOL	CONDITIONS	OP-80E/F			OP-80B			UNITS
			MIN	TYP	MAX	MIN	TYP	MAX	
Input Offset Voltage	$V_{OS}$		–	0.5	5.0	–	1.0	8.0	mV
Input Bias Current	$I_B$	(Note 1)	–	0.3	15	–	0.5	50	$\mu A$
Common-Mode Rejection	CMR	$V_{CM} = -4.75, 3.5V$	50	90	–	50	85	–	dB
Power-Supply Rejection	PSR	$V_S = \pm 2.25V$ to $\pm 8V$	60	85	–	57	80	–	dB
Large-Signal Voltage Gain	$A_{VO}$	$V_O = -4.5V$ to $+3.25V$ , $R_L = 10k\Omega$	50	400	–	20	350	–	V/mV
	$V_O$	$V_S = \pm 5V$ , $R_L = 10k\Omega$	+3.25/ –4.75	+3.7/ –4.9	–	+3.25/ –4.75	+3.7/ –4.9	–	V
Output Voltage Swing	$V_{OH}$	$V_+ = +5V, V_- = 0V$ , $R_L = 10k\Omega$	+3.25	+3.7	–	+3.25	+3.7	–	V
	$V_{OL}$	$V_+ = +5V, V_- = 0V$ , $R_L = 10k\Omega$	–	0.1	1.0	–	0.15	1.0	mV
Supply Current	$I_{SY}$	No Load	–	275	400	–	275	400	$\mu A$
Output Current	$I_{OUT}$	Source	25	35	–	20	35	–	mA
		Sink	15	19	–	15	19	–	

**NOTE:**

 1. Specification applies to  $+85^\circ C$  and  $+125^\circ C$  only.

**ELECTRICAL CHARACTERISTICS** at  $V_S = \pm 5V$ ,  $V_{CM} = 0V$ ,  $T_A = +25^\circ C$ , unless otherwise noted.

PARAMETER	SYMBOL	CONDITIONS	MIN	OP-80G		UNITS
				TYP	MAX	
Input Offset Voltage	$V_{OS}$		–	0.6	2.5	mV
Input Offset Current	$I_{OS}$		–	100	–	fA
Input Bias Current	$I_B$		–	400	2000	fA
Input Voltage Range	IVR	Lower Limit Upper Limit		( $V_- - 0V$ ) ( $V_+ - 1.5V$ )		V
Common-Mode Rejection	CMR	$V_{CM} = -4.75V, 3.5V$	50	90	–	dB
Power-Supply Rejection	PSR	$V_S = \pm 2.25V$ to $\pm 8V$	60	80	–	dB
Large-Signal Voltage Gain	$A_{VO}$	$V_O = -4.5V$ to $+3.25V$ , $R_L = 10k\Omega$	75	350	–	V/mV
	$V_O$	$V_S = \pm 5V$ , $R_L = 10k\Omega$	+3.5/–4.75	+3.7/–4.9	–	V
Output Voltage Swing	$V_{OH}$	$V_+ = +5V, V_- = 0V$ , $R_L = 10k\Omega$	+3.5	+3.7	–	V
	$V_{OL}$	$V_+ = +5V, V_- = 0V$ , $R_L = 10k\Omega$	–	0.2	1	mV

**ELECTRICAL CHARACTERISTICS** at  $V_S = \pm 5V$ ,  $V_{CM} = 0V$ ,  $T_A = +25^\circ C$ , unless otherwise noted. *Continued*

PARAMETER	SYMBOL	CONDITIONS	OP-80G			UNITS
			MIN	TYP	MAX	
Supply Current	$I_{SY}$	No Load	–	220	325	$\mu A$
Input Noise Voltage Density	$e_n$	$f_O = 1000Hz$	–	70	–	$nV/\sqrt{Hz}$
Output Current	$I_{OUT}$	Source Sink	25 15	45 22	–	mA
Slew Rate	SR	$A_V = +1$	0.2	0.4	–	$V/\mu s$
Gain-Bandwidth Product	GBW		–	300	–	kHz
Input Resistance		Common-Mode	–	$10^{16}$	–	$\Omega$
		Differential	–	$10^{13}$	–	

**ELECTRICAL CHARACTERISTICS** at  $V_S = \pm 5V$ ,  $V_{CM} = 0V$ ,  $-40^\circ C \leq T_A \leq +85^\circ C$ , unless otherwise noted.

PARAMETER	SYMBOL	CONDITIONS	OP-80G			UNITS
			MIN	TYP	MAX	
Input Offset Voltage	$V_{OS}$		–	2.0	7.0	mV
Input Bias Current	$I_B$		–	0.6	50	$\mu A$
Common-Mode Rejection	CMR	$V_{CM} = -4.75V, 3.5V$	50	80	–	dB
Power-Supply Rejection	PSR	$V_S = \pm 2.25V$ to $\pm 8V$	57	80	–	dB
Large-Signal Voltage Gain	$A_{VO}$	$V_O = -4.5V$ to $+3.25V$ , $R_L = 10k\Omega$	50	300	–	$V/mV$
	$V_O$	$V_S = \pm 5V$ , $R_L = 10k\Omega$	+3.25/–4.50	+3.7/–4.9	–	V
Output Voltage Swing	$V_{OH}$	$V_+ = +5V, V_- = 0V$ , $R_L = 10k\Omega$	+3.25	+3.7	–	V
	$V_{OL}$	$V_+ = +5V, V_- = 0V$ , $R_L = 10k\Omega$	–	0.2	1	mV
Supply Current	$I_{SY}$	No Load	–	275	400	$\mu A$
Output Current	$I_{OUT}$	Source	25	35	–	mA
		Sink	15	19	–	

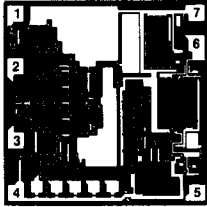
**DICE CHARACTERISTICS**

1. NULL
2. INPUT (-)
3. INPUT (+)
4. V-
5. NULL
6. OUTPUT
7. V+

DIE SIZE 0.070 X 0.069 inch, 4,830 sq. mils  
(1.78 X 1.75mm, 3.12 sq. mm)

For additional DICE ordering information, refer to  
PMI's Data Book, Section 2.

**WAFER TEST LIMITS** at  $V_S = \pm 5V$ ,  $V_{CM} = 0V$ ,  $T_A = 25^\circ C$ , unless otherwise noted.

PARAMETER	SYMBOL	CONDITIONS	OP-80G LIMITS	UNITS
Input Offset Voltage	$V_{OS}$		2.5	mV MAX
Input Bias Current	$I_B$		50	pA MAX
Common-Mode Rejection	CMR	$V_{CM} = -4.75V, +3.5$	50	dB MIN
Power-Supply Rejection	PSR	$V_S = \pm 2.25V$ to $\pm 8V$	60	dB MIN
Large-Signal Voltage Gain	$A_{VO}$	$V_O = -4.5V$ to $+3.25V$ $R_L = 10k\Omega$	75	V/mV MIN
	$V_O$	$V_S = \pm 5V$ , $R_L = 10k\Omega$	+3.5/-4.75	V MIN
Output Voltage Swing	$V_{OH}$	$V_+ = +5V, V_- = 0V$ , $R_L = 10k\Omega$	+3.5	V MIN
	$V_{OL}$	$V_+ = +5V, V_- = 0V$ , $R_L = 10k\Omega$	1	mV MAX
Supply Current	$I_{SY}$	No Load	325	$\mu A$ MAX
Output Current	$I_{OUT}$	Source	25	mA MIN
		Sink	15	

**NOTE:**

Electrical tests are performed at wafer probe to the limits shown. Due to variations in assembly methods and normal yield loss, yield after packaging is not guaranteed for standard product dice. Consult factory to negotiate specifications based on dice lot qualifications through sample lot assembly and testing.

## TYPICAL ELECTRICAL CHARACTERISTICS

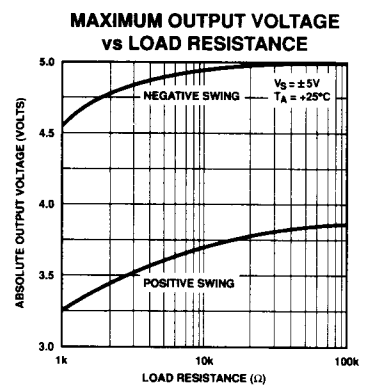
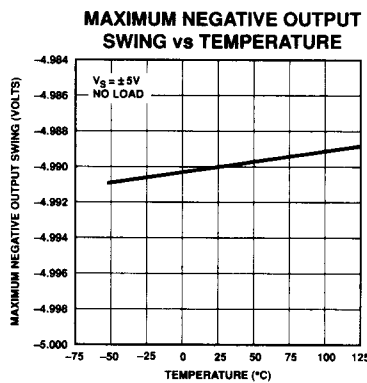
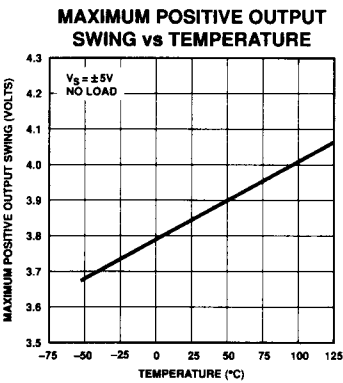
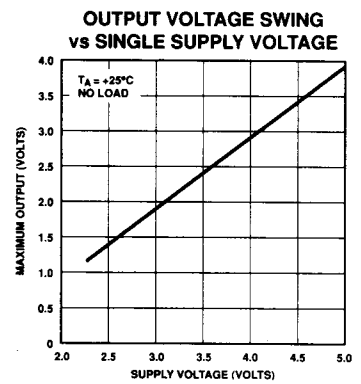
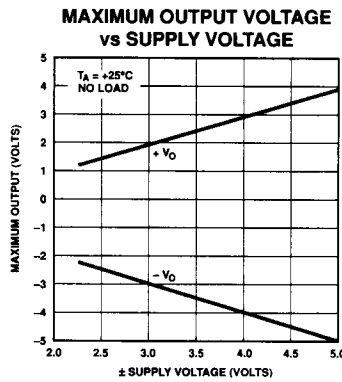
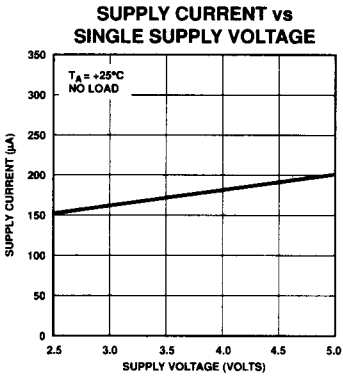
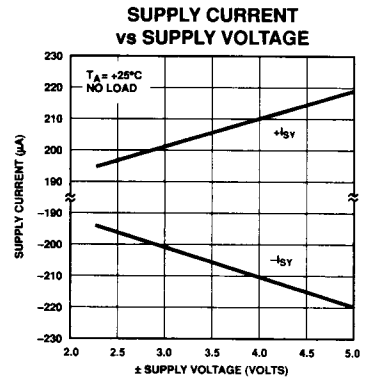
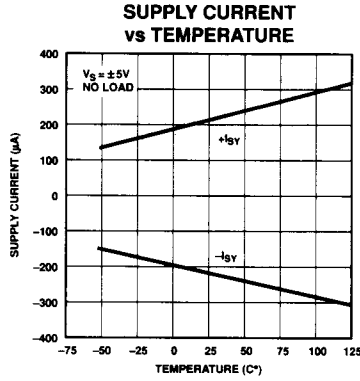
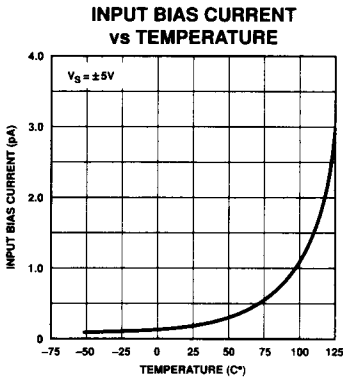

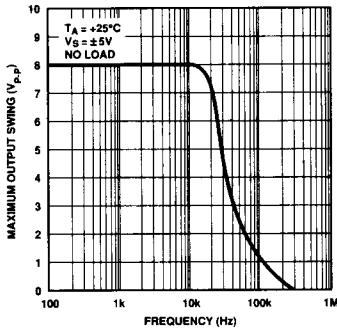
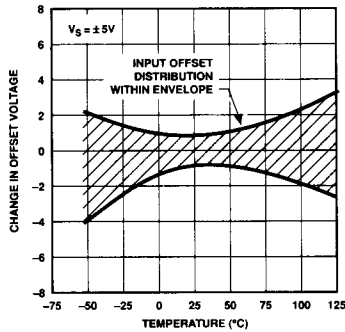
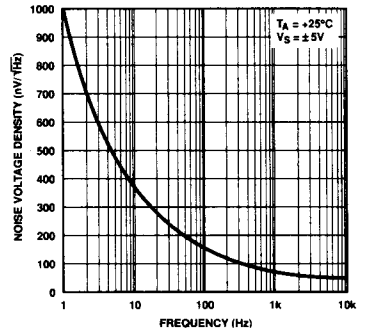
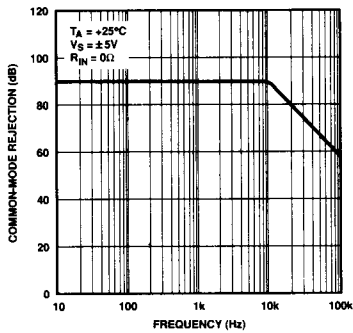
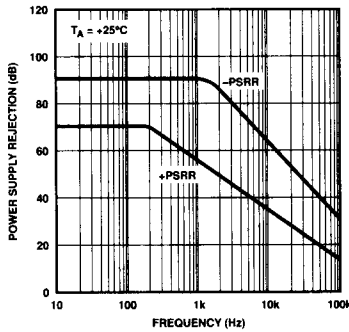
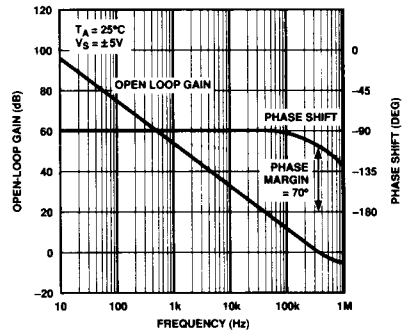
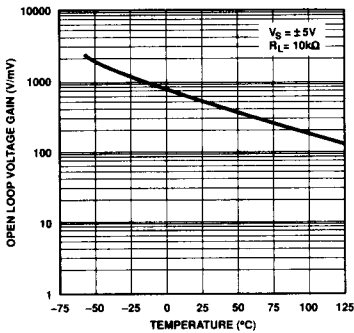
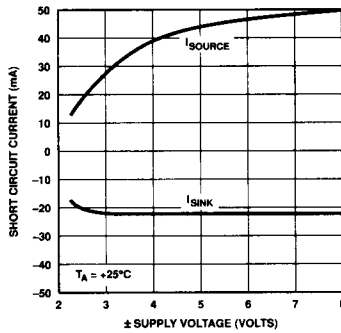
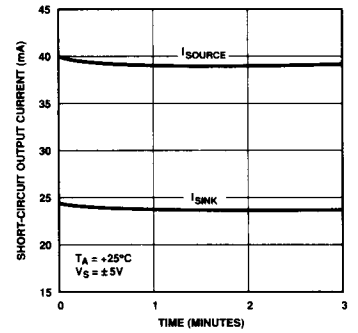
TYPICAL ELECTRICAL CHARACTERISTICS *Continued*
**MAXIMUM OUTPUT SWING vs FREQUENCY**

**INPUT OFFSET VOLTAGE vs TEMPERATURE**

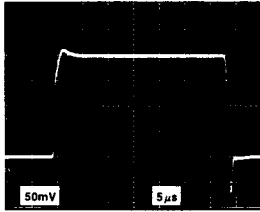
**NOISE VOLTAGE DENSITY vs FREQUENCY**

**COMMON-MODE REJECTION vs FREQUENCY**

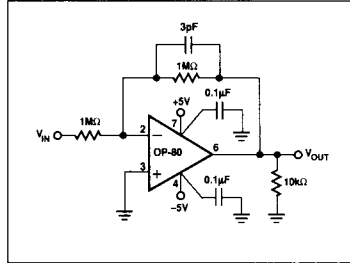
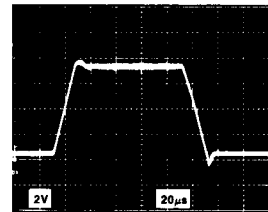
**POWER SUPPLY REJECTION vs FREQUENCY**

**OPEN-LOOP GAIN AND PHASE SHIFT vs FREQUENCY**

**OPEN LOOP GAIN vs TEMPERATURE**

**SHORT CIRCUIT CURRENT vs SUPPLY VOLTAGE**

**SHORT-CIRCUIT OUTPUT CURRENT vs TIME**



TYPICAL ELECTRICAL CHARACTERISTICS *Continued*
**SMALL-SIGNAL  
TRANSIENT RESPONSE**

$T_A = +25^\circ\text{C}$   
 $V_S = \pm 5\text{V}$   
 $R_L = 10\text{k}\Omega$   
 $C_L = 100\text{pF}$   
 $A_V = +1$

**TEST CIRCUIT FOR LARGE-SIGNAL  
TRANSIENT RESPONSE**

**LARGE-SIGNAL  
TRANSIENT RESPONSE**

$T_A = +25^\circ\text{C}$   
 $V_S = \pm 5\text{V}$   
 $R_L = 10\text{k}\Omega$   
 $A_V = -1$

**APPLICATIONS INFORMATION**

Offering one of the lowest input currents of any monolithic operational amplifier, the OP-80 is ideal for use in applications measuring signals from a very high impedance or a very low current source. Operating from a single +5V supply, common-mode input voltages extend to ground with the output swinging to within 200µV of ground. It is a true "single-supply operational amplifier."

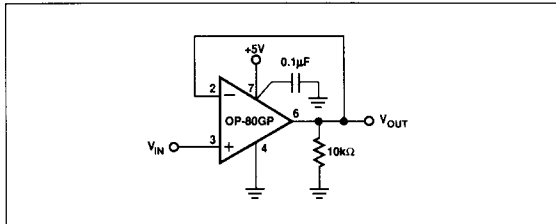
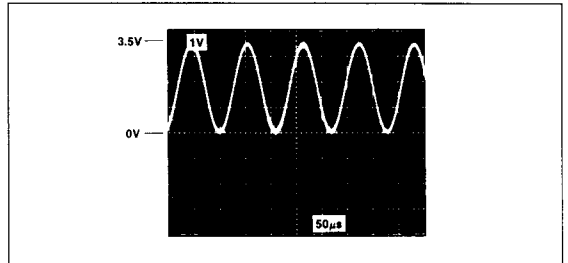
An example of this single-supply operation is illustrated in Figure 1. The OP-80, configured as a unity gain voltage-follower with a single +5V supply, can be operated down to ground, as shown by the 10kHz sine wave output in Figure 2. Typical of CMOS op amp operation, the output stage of the OP-80 requires a output load resistance of 1MΩ or less.

**FIGURE 1: Unity Voltage Gain Follower, Single +5V Supply**

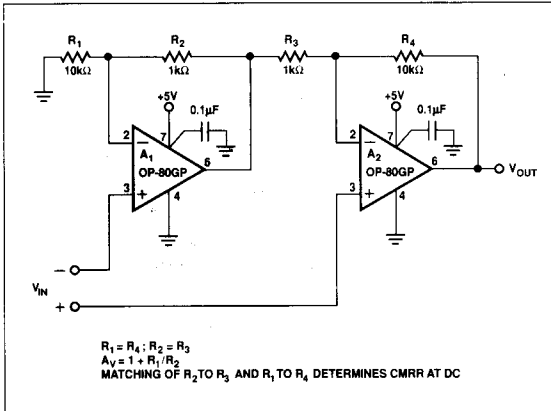
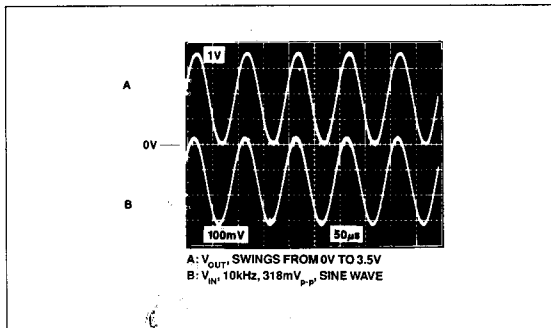
**FIGURE 2: Voltage Follower Response, 10kHz Sine Wave  $V_S = +5\text{V}$ ,  $R_L = 10\text{k}\Omega$ . Note that output extends to ground.**

**FIGURE 3: True Single Supply Instrumentation Amplifier**

**FIGURE 4: Sine Wave Response**

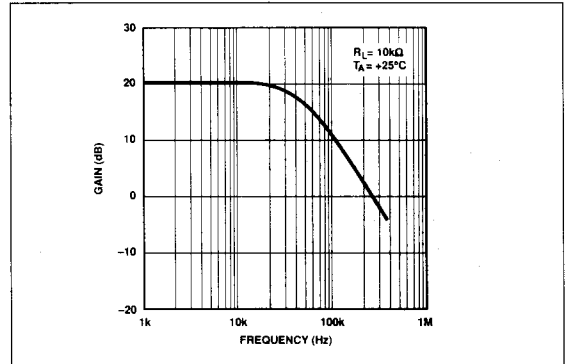
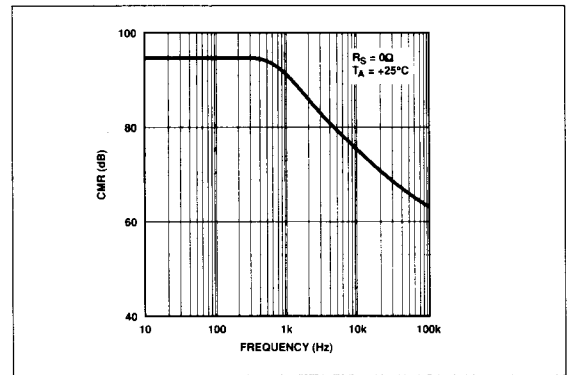
### A TRUE SINGLE SUPPLY INSTRUMENTATION AMPLIFIER

The circuit in Figure 3 shows an instrumentation amplifier operated from a single +5V supply. This amplifier is quite useful for battery-powered instrument applications since it consumes a supply current of less than 400 $\mu$ A, and the output signal can swing down to ground level, as illustrated in Figure 4.

**FIGURE 5: Instrumentation Amplifier Frequency Response**

**FIGURE 6: Instrumentation Amplifier Common-Mode Rejection**

Although this amplifier topology is not symmetrically balanced, as in a three op-amp instrumentation amplifier, a common-mode rejection of 70dB is still maintained over a signal bandwidth of 20kHz as shown in Figures 5 and 6. Finite open-loop gain of  $A_1$  causes feedthrough of the common-mode input which may be improved by trimming  $R_1$ .

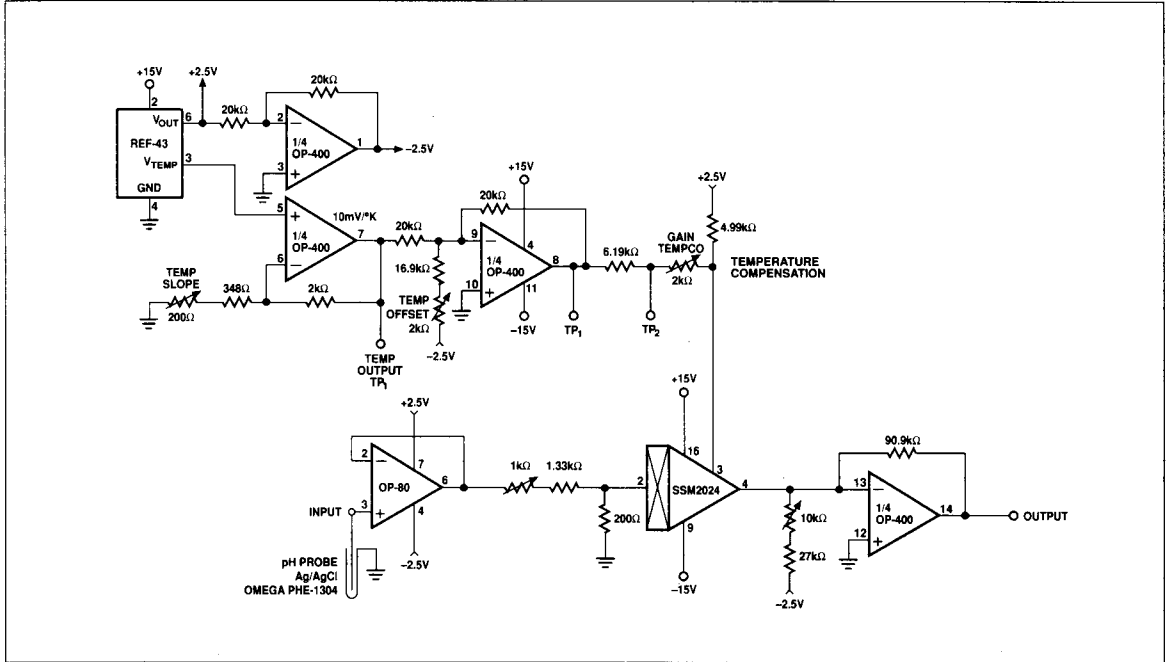

FIGURE 7: A Complete, Temperature-Compensated pH Meter Design

### IDEAL FOR A pH METER

Since the OP-80 has an extremely high input impedance, it is ideal for pH/Ion sensitive electrode applications. Figure 7 illustrates an OP-80 used to buffer the extremely high impedance of a pH probe. The meter includes a temperature compensation circuit for the probe.

The output voltage of the pH probe is linearly dependent on the pH of the sample solution and the sample temperature. A current-controlled amplifier, the SSM2024, is driven by a temperature dependent signal to account for the change in the pH probe's output voltage due to sample temperature variations.

After the pH meter is calibrated, it will have an output of 1V/pH from  $2 \leq \text{pH} \leq 12$  and is accurate to 0.01 pH at 25°C and 0.05pH from 0°C to 70°C.

The REF-43's  $V_{\text{TEMP}}$  output provides an output voltage proportional to a temperature, typically 1.9mV/°C. This temperature dependent signal is conditioned and used to provide the correction signal to the current controlled amplifier.

### pH Meter Calibration Procedure

1. With  $T_A = +25^\circ\text{C}$  adjust temperature slope for 2.98V temperature output.
2. Adjust temperature offset @ 25°C for -0.25V at TP<sub>1</sub>.
3. Short TP<sub>2</sub> to ground.
4. Apply 0V to input (with pH probe disconnected).
5. Adjust offset for 7V output.
6. Apply +271 mV to input; adjust gain trim for 2V output.
7. For improved accuracy, repeat steps 4, 5 and 6 as these adjustments are interactive.
8. Remove ground short from TP<sub>2</sub>.
9. With  $T_A = 25^\circ\text{C}$ , apply +295.6mV to input; adjust gain tempco for 2V output. For highest accuracy, use a buffer solution at a known pH and temperature and set gain tempco for proper output. Remember, to properly set the temperature calibration, the REF-43 must be placed in thermal contact with the solution under test.

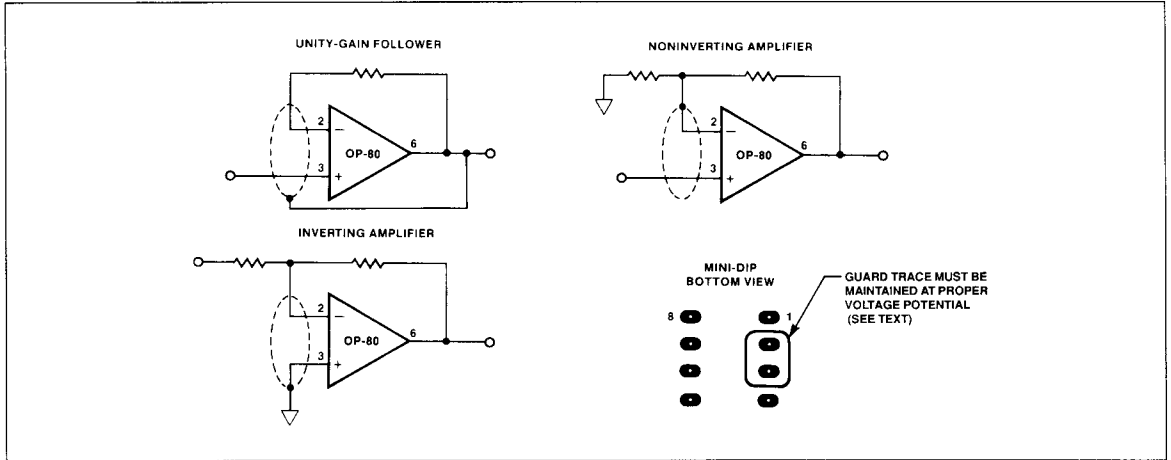
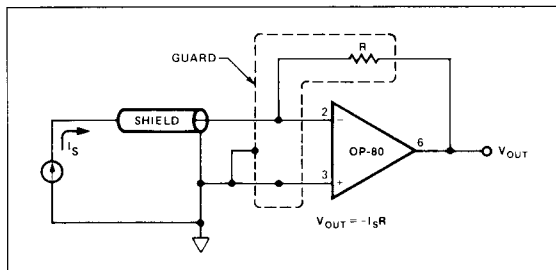

**FIGURE 8:** *Guard Ring Layout and Connections*

### GUARDING AND SHIELDING

To maintain the extremely high input impedances of the OP-80, care must be taken in circuit board layout and manufacturing. Board surfaces must be kept scrupulously clean and free of moisture. Conformal coating is recommended to provide a humidity barrier. Even a clean PC board can have 100pA of leakage currents between adjacent traces where a potential difference is present, so that guard rings should be used around the inputs. Guard traces should be driven at a voltage equal to or close to that of the inputs, so that leakage currents are kept at a minimum. In noninverting applications, the guard ring should be connected to the common-mode voltage at the inverting input (pin 2).

When the OP-80 is operated in the inverting mode, as in Figure 9, the signal traces should have grounded guard traces on both sides of the PC board since both inputs remain at ground voltage potential.

High impedance circuitry is extremely susceptible to RF pickup, line-frequency hum, and radiated noise from switching power-supplies. Enclosing sensitive analog sections within grounded shields is generally necessary to prevent excessive noise pickup. Twisted-pair cable will aid in rejection of line-frequency hum.

**FIGURE 9:** *Current-to-Voltage Converter*

The OP-80's AC characteristics are highly stable over a wide range of operating conditions. Due to the extremely high input impedance, the OP-80 can be used with large source impedances, such as I-V converter applications. Input capacitance, with high source impedances, can substantially degrade signal bandwidth and stability margins. Accordingly, guarding the input lines will not only reduce parasitic leakage, but stray capacitance at the input node will also be minimized.

To cancel the effect of the input capacitance, the pole created must be neutralized by a zero that is located at the same frequency. To introduce this zero, place a capacitor,  $C_F$ , around the feedback resistor with a value such that:

$$\frac{1}{2\pi R_1 C_{IN}} \geq \frac{1}{2\pi R_2 C_F}$$

$$\text{or } R_1 C_{IN} \leq R_2 C_F$$

$R_1$  is modelled as a Thevenin equivalent impedance for I-V converter applications.

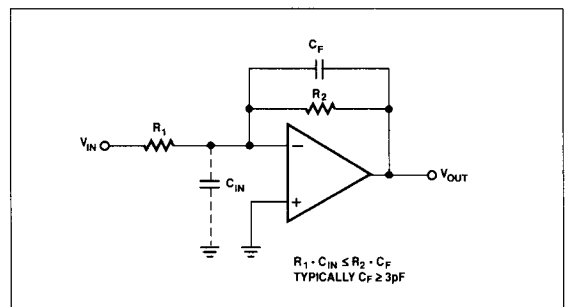
**FIGURE 10:** *Cancelling the Effect of Input Capacitance*