

CMOS 0 to 36 MHz Single Chip 8-bit Microcontroller

Description

TEMIC's 80C154 and 83C154 are high performance CMOS single chip μ C. The 83C154 retains all the features of the 80C52 with extended ROM capacity (16 K bytes), 256 bytes of RAM, 32 I/O lines, a 6-source 2-level interrupts, a full duplex serial port, an on-chip oscillator and clock circuits, three 16 bit timers with extra features : 32 bit timer and watchdog functions. Timer 0 and 1 can be configured by program to implement a 32 bit timer. The watchdog function can be activated either with timer 0 or timer 1 or both together (32 bit timer).

In addition, the 83C154 has 2 software-selectable modes of reduced activity for further reduction in power

consumption. In the idle mode the CPU is frozen while the RAM is saved, and the timers, the serial port and the interrupt system continue to function. In the power down mode the RAM is saved and the timers, serial port and interrupt continue to function when driven by external clocks. In addition as for the TEMIC 80C51/80C52, the stop clock mode is also available.

The 80C154 is identical to the 83C154 except that it has no on-chip ROM. TEMIC's 80C154 and 83C154 are manufactured using SCMOS process which allows them to run from 0 up to 36 MHz with $V_{cc} = 5$ V.

- 80C154 : ROMless version of the 83C154 μ
- 80C154/83C154-12 : 0 to 12 MHz
- 80C154/83C154-16 : 0 to 16 MHz
- 80C154/83C154-20 : 0 to 20 MHz
- 80C154/83C154-25 : 0 to 25 MHz
- 80C154/83C154-30 : 0 to 30 MHz

- 80C154/83C154-36 : 0 to 36 MHz
- 80C154/83C154-L16 : Low power version
VCC : 2.7-5.5 V Freq : 0-16 MHz

For other speed and temperature range availability please consult your sales office.

Features

- Power control modes
- 256 bytes of RAM
- 16 Kbytes of ROM (83C154)
- 32 Programmable I/O lines (programmable impedance)
- Three 16 bit timer/counters (including watchdog and 32 bit timer)
- 64 K program memory space
- 64 K data memory space
- Fully static design
- 0.8 μ CMOS process
- Boolean processor
- 6 interrupt sources
- Programmable serial port
- Temperature range : commercial, industrial, automotive, military

Optional

- Secret ROM : Encryption
- Secret TAG : Identification number

Interface

Figure 1. Block Diagram

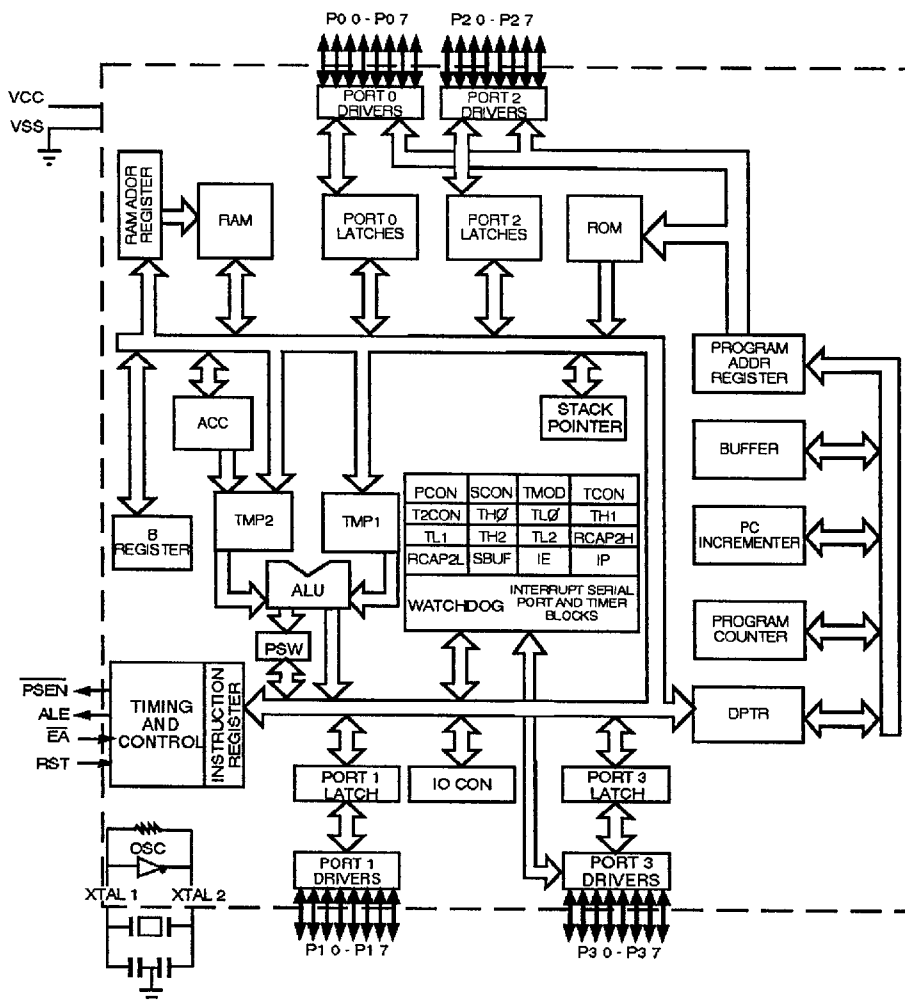
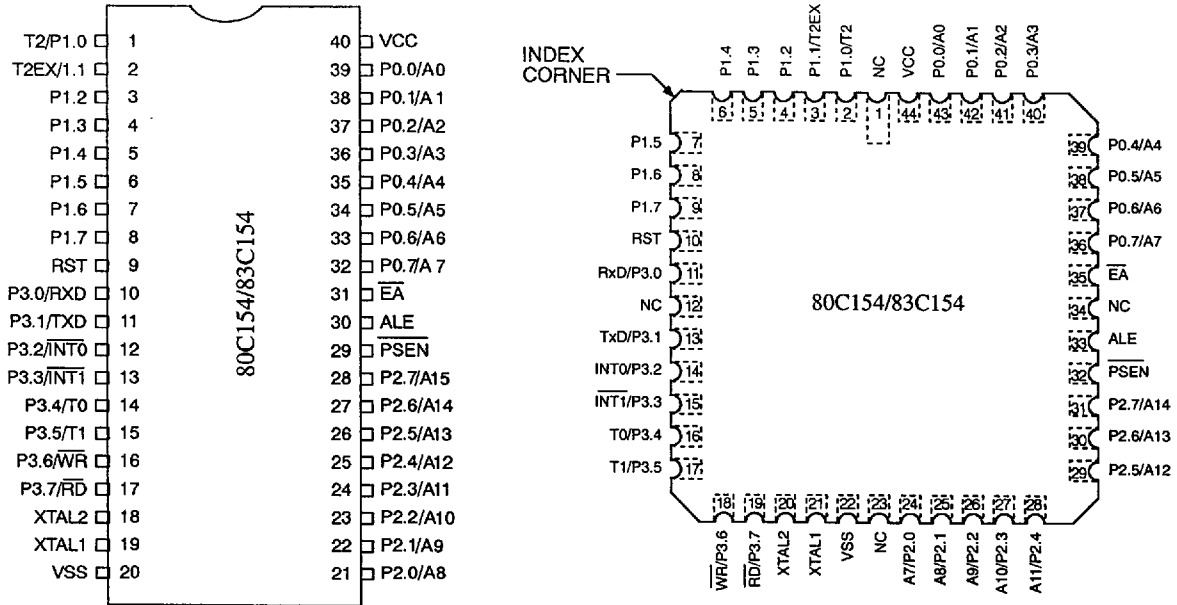
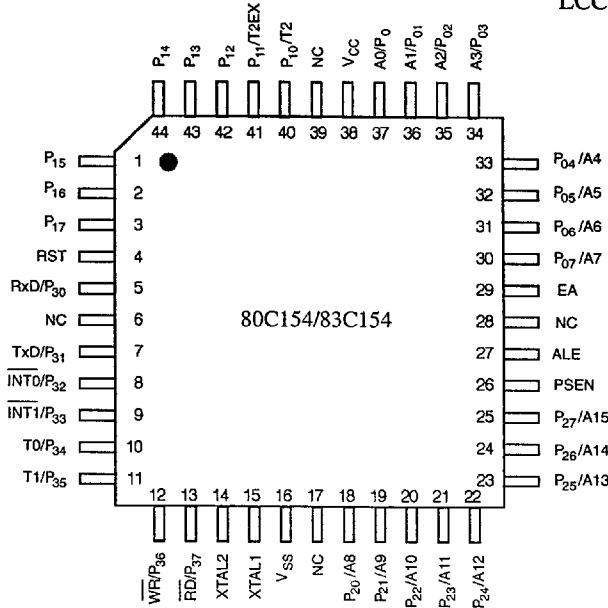

Figure 2. Pin Configuration



DIL

LCC



Flat Pack

Diagrams are for reference only. Package sizes are not to scale

Pin Description

Vss

Circuit Ground Potential.

VCC

Supply voltage during normal, Idle, and Power Down operation.

Port 0

Port 0 is an 8 bit open drain bi-directional I/O port. Port 0 pins that have 1's written to them float, and in that state can be used as high-impedance inputs.

Port 0 is also the multiplexed low-order address and data bus during accesses to external Program and Data Memory. In this application it uses strong internal pullups when emitting 1's. Port 0 also outputs the code bytes during program verification in the 83C154. External pullups are required during program verification. Port 0 can sink eight LS TTL inputs.

Port 1

Port 1 is an 8 bit bi-directional I/O port with internal pullups. Port 1 pins that have 1's written to them are pulled high by the internal pullups, and in that state can be used as inputs. As inputs, Port 1 pins that are externally being pulled low will source current (I_{IL}, on the data sheet) because of the internal pullups.

Port 1 also receives the low-order address byte during program verification. In the 83C154, Port 1 can sink or source three LS TTL inputs. It can drive CMOS inputs without external pullups.

2 inputs of PORT 1 are also used for timer/counter 2 :

P1.0 [T2] : External clock input for timer/counter 2. P1.1 [T2EX] : A trigger input for timer/counter 2, to be reloaded or captured causing the timer/counter 2 interrupt.

Port 2

Port 2 is an 8 bit bi-directional I/O port with internal pullups. Port 2 pins that have 1's written to them are pulled high by the internal pullups, and in that state can be used as inputs. As inputs, Port 2 pins that are externally being pulled low will source current (I_{IL}, on the data sheet) because of the internal pullups. Port 2 emits the high-order address byte during fetches from external Program Memory and during accesses to external Data Memory that use 16 bit addresses (MOVX @DPTR). In this application, it uses strong internal pullups when emitting 1's. During accesses to external Data Memory that use 8 bit addresses (MOVX @Ri), Port 2 emits the contents of the P2 Special Function Register.

It also receives the high-order address bits and control signals during program verification in the 83C154. Port 2 can sink or source three LS TTL inputs. It can drive CMOS inputs without external pullups.

Port 3

Port 3 is an 8 bit bi-directional I/O port with internal pullups. Port 3 pins that have 1's written to them are pulled high by the internal pullups, and in that state can be used as inputs. As inputs, Port 3 pins that are externally being pulled low will source current (I_{IL}, on the data sheet) because of the pullups. It also serves the functions of various special features of the TEMIC 51 Family, as listed below.

Port Pin	Alternate Function
P3.0	RXD (serial input port)
P3.1	TXD (serial output port)
P3.2	$\overline{\text{INT0}}$ (external interrupt 0)
P3.3	$\overline{\text{INT1}}$ (external interrupt 1)
P3.4	TD (Timer 0 external input)
P3.5	T1 (Timer 1 external input)
P3.6	$\overline{\text{WR}}$ (external Data Memory write strobe)
P3.7	RD (external Data Memory read strobe)

Port 3 can sink or source three LS TTL inputs. It can drive CMOS inputs without external pullups.

RST

A high level on this for two machine cycles while the oscillator is running resets the device. An internal pull-down resistor permits Power-On reset using only a capacitor connected to VCC. As soon as the result is applied (Vin), PORT 1, 2 and 3 are tied to 1. This operation is achieved asynchronously even if the oscillator is not start up.

ALE

Address Latch Enable output for latching the low byte of the address during accesses to external memory. ALE is activated as though for this purpose at a constant rate of 1/6 the oscillator frequency except during an external data memory access at which time one ALE pulse is skipped. ALE can sink or source 8 LS TTL inputs. It can drive CMOS inputs without an external pullup.

PSEN

Program Store Enable output is the read strobe to external Program Memory. PSEN is activated twice each machine cycle during fetches from external Program Memory. (However, when executing out of external Program Memory, two activations of PSEN are skipped during each access to external Data Memory). PSEN is not activated during fetches from internal Program Memory. PSEN can sink/source 8 LS TTL inputs. It can drive CMOS inputs without an external pullup.

EA

When EA is held high, the CPU executed out of internal Program Memory (unless the Program Counter exceeds 3FFFH). When EA is held low, the CPU executes only out of external Program Memory. EA must not be floated.

XTAL1

Input to the inverting amplifier that forms the oscillator. Receives the external oscillator signal when an external oscillator is used.

XTAL2

Output of the inverting amplifier that forms the oscillator, and input to the internal clock generator. This pin should be floated when an external oscillator is used.

Idle and Power Down Operation

Figure 3 shows the internal Idle and Power Down clock configuration. As illustrated, Power Down operation stops the oscillator. The interrupt, serial port, and timer blocks continue to function only with external clock (INT0, INT1, T0, T1).

Idle Mode operation allows the interrupt, serial port, and timer blocks to continue to function with internal or external clocks, while the clock to CPU is gated off. The special modes are activated by software via the Special Function Register, PCON. Its hardware address is 87H. PCON is not bit addressable.

Figure 3. Idle and Power Down Hardware.

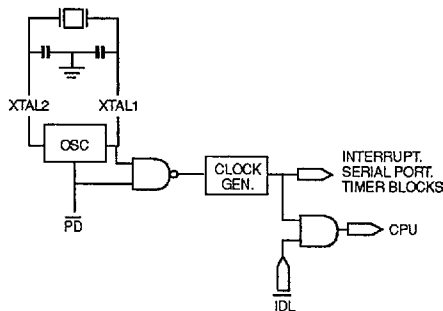

PCON : Power Control Register

(MSB)							(LSB)
SMOD	HPD	RPD	-	GF1	GF0	PD	IDL

Symbol	Position	Name and Function
SMOD	PCON.7	Double Baud rate bit. When set to a 1, the baud rate is doubled when the serial port is being used in either modes 1, 2 or 3.
HPD	PCON.6	Hard power Down bit. Setting this bit allows CPU to enter in Power Down state on an external event (1 to 0 transition) on bit T1 (p. 3.5) the CPU quit the Hard Power Down mode when bit T1 p. 3.5) goes high or when reset is activated.
RPD	PCON.5	Recover from Idle or Power Down bit. When 0 RPD has no effect. When 1, RPD permits to exit from idle or Power Down with any non enabled interrupt source (except time 2). In this case the program start at the next address. When interrupt is enabled, the appropriate interrupt routine is serviced.
GF1	PCON.3	General-purpose flag bit.
GF0	PCON.2	General-purpose flag bit.
PD	PCON.1	Power Down bit. Setting this bit activates power down operation.
IDL	PCON.0	Idle mode bit. Setting this bit activates idle mode operation.

If 1's are written to PD and IDL at the same time. PD takes, precedence. The reset value of PCON is (000X0000).

Idle Mode

The instruction that sets PCON.0 is the last instruction executed before the Idle mode is activated. Once in the Idle mode the CPU status is preserved in its entirety : the Stack Pointer, Program Counter, Program Status Word, Accumulator, RAM and all other registers maintain their data during idle. In the idle mode, the internal clock signal is gated off to the CPU, but interrupt, timer and serial port functions are maintained. Table 1 describes the status of the external pins during Idle mode. There are three ways to terminate the Idle mode. Activation of any enabled interrupt will cause PCON.0 to be cleared by hardware, terminating Idle mode. The interrupt is serviced, and following RETI, the next instruction to be executed will be the one following the instruction that wrote 1 to PCON.0.

The flag bits GF0 and GF1 may be used to determine whether the interrupt was received during normal execution or during the Idle mode. For example, the instruction that writes to PCON.0 can also set or clear one or both flag bits. When Idle mode is terminated by an enabled interrupt, the service routine can examine the status of the flag bits.

The second way of terminating the Idle mode is with a hardware reset. Since the oscillator is still running, the hardware reset needs to be active for only 2 machine cycles (24 oscillator periods) to complete the reset operation.

The third way to terminate the Idle mode is the activation of any disabled interrupt when recover is programmed (RPD = 1). This will cause PCON.0 to be cleared. No interrupt is serviced. The next instruction is executed. If interrupt are disabled and RPD = 0, only a reset can cancel the Idle mode.

Power Down Mode

The instruction that sets PCON.1 is the last executed prior to entering power down. Once in power down, the oscillator is stopped. The contents of the onchip RAM and the Special Function Register is saved during power down mode. The three ways to terminate the Power Down mode are the same than the Idle mode. But since the onchip oscillator is stopped, the external interrupts, timers and serial port must be sourced by external clocks only, via INTO, INT1, T0, T1.

In the Power Down mode, VCC may be lowered to minimize circuit power consumption. Care must be taken to ensure the voltage is not reduced until the power down mode is entered, and that the voltage is restored before the hardware reset is applied which frees the oscillator. Reset should not be released until the oscillator has restarted and stabilized.

When using voltage reduction : interrupt, timers and serial port functions are guaranteed in the VCC specification limits.

Table 1 describes the status of the external pins while in the power down mode. It should be noted that if the power down mode is activated while in external program memory, the port data that is held in the Special Function Register P2 is restored to Port 2. If the port switches from 0 to 1, the port pin is held high during the power down mode by the strong pullup, T1, shown in figure 4.

Table 1. Status of the external pins during idle and power down modes.

MODE	PROGRAM MEMORY	ALE	PSEN	PORT0	PORT1	PORT2	PORT3
Idle	Internal	1	1	Port Data	Port Data	Port Data	Port Data
Idle	External	1	1	Floating	Port Data	Address	Port Data
Power Down	Internal	0	0	Port Data	Port Data	Port Data	Port Data
Power Down	External	0	0	Floating	Port Data	Port Data	Port Data

Figure 4. I/O Buffers in the 83C154 (Ports 1, 2, 3).

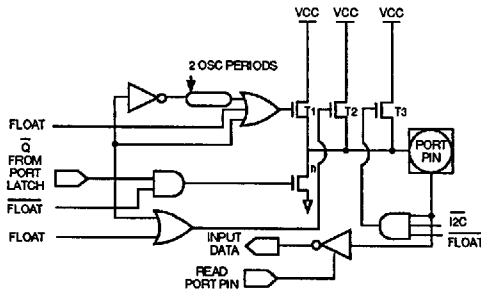

Stop Clock Mode

Due to static design, the TEMIC 83C154 clock speed can be reduced until 0 MHz without any data loss in memory or registers. This mode allows step by step utilization, and permits to reduce system power consumption by bringing the clock frequency down to any value. At 0 MHz, the power consumption is the same as in the Power Down Mode.

I/O Ports

The I/O drives for P1, P2, P3 of the 83C154 are impedance programmable. The I/O buffers for Ports 1, 2 and 3 are implemented as shown in figure 4.

When the port latch contains 0, all pFETS in figure 4 are off while the nFET is turned on. When the port latch makes a 0-to-1 transition, the nFET turns off. The strong pullup pFET, T1, turns on for two oscillator periods, pulling the output high very rapidly. As the output line is drawn high, pFET T3 turns on through the inverter to supply the IOH source current. This inverter and T3 form a latch which holds the 1 and is supported by T2. When Port 2 is used as an address port, for access to external program of data memory, any address bit that contains a 1 will have his strong pullup turned on for the entire duration of the external memory access.

When an I/O pin on Ports 1, 2, or 3 is used as an input, the user should be aware that the external circuit must sink current during the logical 1-to-0 transition. The

maximum sink current is specified as I_{TL} under the D.C. Specifications. When the input goes below approximately 2 V, T3 turns off to save ICC current. Note, when returning to a logical 1, T2 is the only internal pullup that is on. This will result in a slow rise time if the user's circuit does not force the input line high.

The input impedance of Port 1, 2, 2 are programmable through the register IOCON. The ALF bit (IOCON0) set all of the Port 1, 2, 3 floating when a Power Down mode occurs. The P1HZ, P2HZ, P3HZ bits (IOCON1, IOCON2, IOCON3) set respectively the Ports P1, P2, P3 in floating state. The IZC (IOCON4) allows to choose input impedance of all ports (P1, P2, P3). When IZC = 0, T2 and T3 pullup of I/O ports are active; the internal input impedance is approximately 10 K. When IZC = 1 only T2 pull-up is active. The T3 pull-up is turned off by IZC. The internal impedance is approximately 100 K.

Oscillator Characteristics

XTAL1 and XTAL2 are the input and output respectively, of an inverting amplifier which is configured for use as an on-chip oscillator, as shown in figure 5. Either a quartz crystal or ceramic resonator may be used.

Figure 5. Crystal Oscillator.

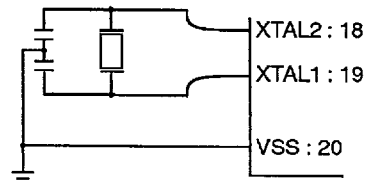

To drive the device from an external clock source, XTAL1 should be driven while XTAL2 is left unconnected as shown in figure 6. There are no requirements on the duty cycle of the external clock signal, since the input to the internal clocking circuitry is through a divide-by-two flip-flop, but minimum and maximum high and low times specified on the Data Sheet must be observed.

Figure 6. External Drive Configuration.

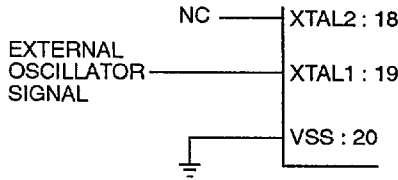

Hardware Description

Same as for the 80C51, plus a third timer/counter :

Timer/Event Counter 2

Timer 2 is a 16 bit timer/counter like Timers 0 and 1, it can operate either as a timer or as an event counter. This is selected by bit $C/\overline{T}2$ in the Special Function Register T2CON (Figure 1). It has three operating modes : "capture", "autoload" and "baud rate generator", which are selected by bits in T2CON as shown in Table 2.

Table 2. Timer 2 Operating Modes.

RCLK + TCLK	CP/RL2	TR2	MODE
0	0	1	16 bit auto-reload
0	1	1	16 bit capture
1	X	1	baud rate generator
X	X	0	(off)

In the capture mode there are two options which are selected by bit EXEN2 in T2CON; If EXEN2 = 0, then Timer 2 is a 16 bit timer or counter which upon overflowing sets bit TF2, the Timer 2 overflow bit, which can be used to generate an interrupt. If EXEN2 = 1, then Timer 2 still does the above, but with the added feature that a 1-to-0 transition at external input T2EX causes the current value in the Timer 2 registers, TL2 and TH2, to be captured into registers RCAP2L and RCAP2H, respectively. In addition, the transition at T2EX causes bit EXF2 in T2CON to be set, and EXF2, like TF2, can generate an interrupt.

The capture mode is illustrated in Figure 7.

In the auto-reload mode there are again two options, which are selected by bit EXEN2 in T2CON. If

EXEN2 = 0, then when Timer 2 rolls over it does not only set TF2 but also causes the Timer 2 register to be reloaded with the 16 bit value in registers RCAP2L and RCAP2H, which are preset by software. If EXEN2 = 1, then Timer 2 still does the above, but with the added feature that a 1-to-0 transition at external input T2EX will also trigger the 16 bit reload and set EXF2.

The auto-reload mode is illustrated in Figure 8.

Figure 7. Timer 2 in Capture Mode.

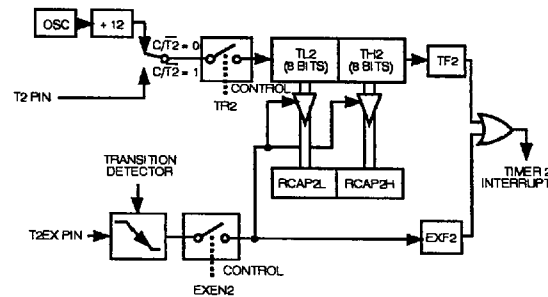
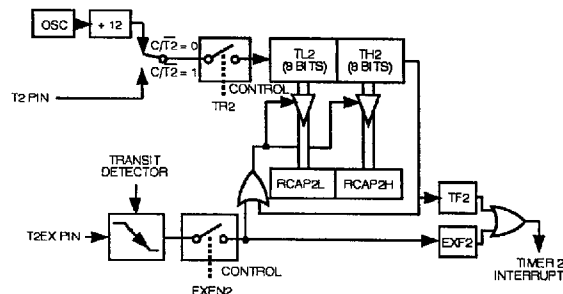

Figure 8. Timer 2 in Auto-Reload Mode.



(MSB)						(LSB)	
TF2	EXF2	RCLK	TCLK	EXEN2	TR2	C/T $\bar{2}$	CP/RL $\bar{2}$

The baud rate generator mode is selected by : RCLK = 1 and/or TCLK = 1.

Symbol	Position	Name and Significance
TF2	T2CON.7	Timer 2 overflow flag set by a Timer 2 overflow and must be cleared by software. TF2 will not be set when either RCLK = 1 OR TCLK = 1.
EXF2	T2CON.6	Timer 2 external flag set when either a capture or reload is caused by a negative transition on T2EX and EXEN2 = 1. When Timer 2 interrupt is enabled, EXF2 = 1 will cause the CPU to vector to the Timer 2 interrupt routine. EXF2 must be cleared by software.
RCLK	T2CON.5	Receive clock flag. When set, causes the serial port to use Timer2 overflow pulses for its receive clock in modes 1 and 3. RCLK = 0 causes Timer 1 overflow to be used for the receive clock.
TCLK	T2CON.4	Transmit clock flag. When set, causes the serial port to use Timer 2 overflow pulses for its transmit clock in modes 1 and 3. TCLK = 0 causes Timer 1 overflows to be used for the transmit clock.
EXEN2	T2CON.3	Timer 2 external enable flag. When set, allows capture or reload to occur as a result of a negative transition on T2EX if Timer 2 is not being used to clock the serial port. EXEN2 = 0 causes Timer 2 to ignore events at T2EX.
TR2	T2CON.2	Start/stop control for Timer 2. A logic 1 starts the timer.
C/T $\bar{2}$	T2CON.1	Timer or counter select. (Timer 2) 0 = Internal timer (OSC/12) 1 = External event counter (falling edge triggered).
CP/RL $\bar{2}$	T2CON.0	Capture/Reload flag. When set, captures will occur on negative transitions at T2EX if EXEN2 = 1. When cleared, auto reloads will occur either with Timer 2 overflows or negative transition at T2EX when EXEN2 = 1. When either RCLK = 1 or TCLK = 1, this bit is ignored and the timer is forced to auto-reload on Timer 2 overflow.

Timer Functions

In fact, timer 0 & 1 can be connected by a software instruction to implement a 32 bit timer function. Timer 0 (mode 3) or timer 1 (mode 0, 1, 2) or a 32 bit timer consisting of timer 0 + timer 1 can be employed in the watchdog mode, in which case a CPU reset is generated upon a TF1 flag.

The internal pull-up resistances at ports 1~3 can be set to a ten times increased value simply by software.

32 Bit Mode and Watching Mode

The 83C154 has two supplementary modes. They are accessed by bits WDT and T32 of register IOCON. Figure 10 shows how IOCON must be programmed in order to have access to these functions

Figure 9.

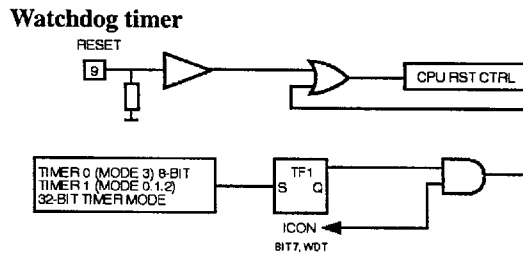

32 bit timer [IOCON bit 6 (T32) = 1]

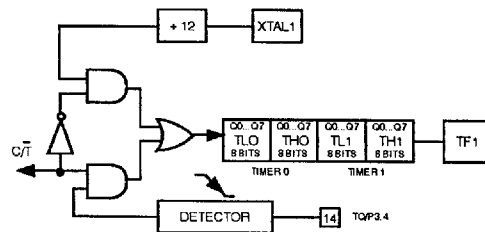

(MSB)	(LSB)						
WDT	T32	SERR	IZC	P3HZ	P2HZ	P1HZ	ALF

Symbol	Position	Name and Significance
T32	IOCON.6	- If T32 = 1 and if C/T0 = 0, T1 and T0 are programmed as a 32 bit TIMER. - If T32 = 1 and if C/T0 = 1, T1 and T0 are programmed as a 32 bit COUNTER.
WDT	IOCON.7	- If WDT = 1 and according to the mode selected by TMOD, an 8 bit or 32 bit WATCHDOG is configured from TIMERS 0 and 1.

32 Bit Mode

- T32 = 1 enables access to this mode. As shown in figure 11, this 32 bit mode consists in cascading TIMER 0 for the LSBs and TIMER 1 for the MSBs

Figure 10.32 Bit Timer/counter.

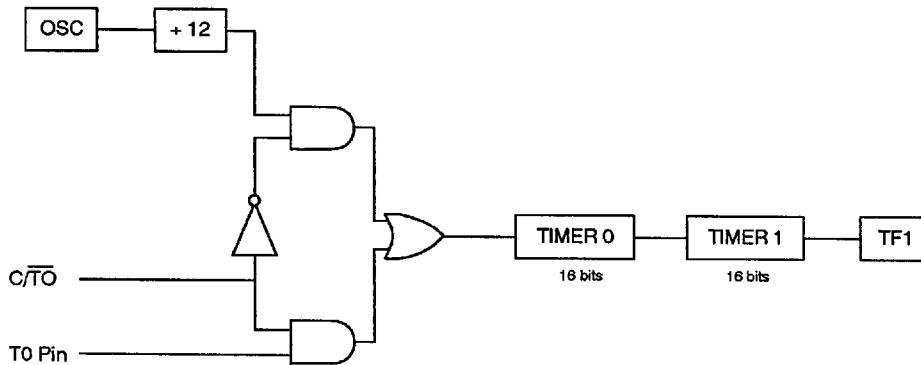

T32 = 1 starts the timer/counter and T32 = 0 stops it. It should be noted that as soon as T32 = 0, TIMERS 0 and 1 assume the configuration specified by register TMOD. Moreover, if TR0 = 1 or if TR1 = 1, the content of the

TIMERS evolves. Consequently, in 32 bit mode, if the TIMER/COUNTER must be stopped (T32 = 0), TR0 and TR1 must be set to 0.

32 Bit Timer

- Figure 12 illustrates the 32 bit TIMER mode.

Figure 11. 32 Bit Timer Configuration.



- In this mode, T32 = 1 and C/T0 = 0, the 32 bit timer is incremented on each S3P1 state of each machine cycle. An overflow of TIMER 0 (TF0 has not been set to 1) increments TIMER 1 and the overflow of the 32 bit TIMER is signalled by setting TF1 (S5P1) to 1.

- The following formula should be used to calculate the required frequency :

$$f = \frac{OSC}{12 \times (65536 - (T0, T1))}$$

32 Bit Counter

Figure 13 illustrates the 32 bit COUNTER mode.

Figure 12. 32 Bit Counter Configuration.

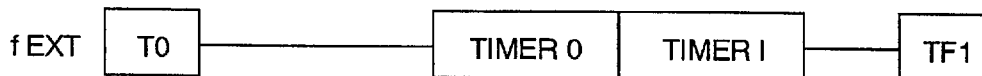

- In this mode, $T32 = 0$ and $C/\overline{T0} = 1$. Before it can make an increment, the 83C154 μ must detect two transitions on its T0 input. As shown in figure 14,

input T0 is sampled on each S5P2 state of every machine cycle or, in other words, every $OSC \div 12$.

Figure 13. Counter Incrementation Condition.

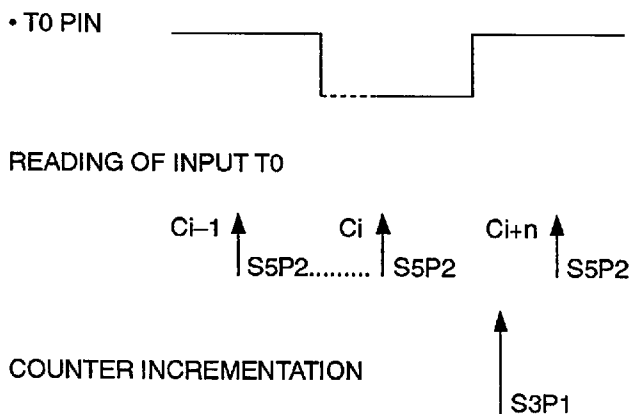

- The counter will only evolve if a level 1 is detected during state S5P2 of cycle C_i and if a level 0 is detected during state S5P2 of cycle $C_i + n$.
- Consequently, the minimal period of signal f_{EXT} admissible by the counter must be greater than or equal to two machine cycles. The following formula should be used to calculate the operating frequency.

$$f = \frac{f_{EXT}}{65536 - (T0, T1)}$$

$$f_{EXT} < \frac{OSC}{24}$$

Watchdog Mode

- $WDT = 1$ enables access to this mode. As shown in figure 15, all the modes of TIMERS 0 and 1, of which the overflows act on TF1 ($TF1 = 1$), activate the WATCHDOG Mode.

Figure 14. The Different Watchdog Configurations.

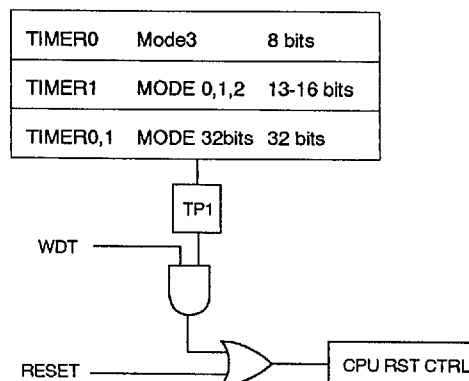

- If $C/\bar{T} = 0$, the WATCHDOG is a TIMER that is incremented every machine cycle. If $C/\bar{T} = 1$, the WATCHDOG is a counter that is incremented by an external signal of which the frequency cannot exceed $OSC + 24$.
- The overflow of the TIMER/COUNTER is signalled by raising flag TF1 to 1. The reset of the 83C154 is executed during the next machine cycle and lasts for the next 5 machine cycles. The results of this reset are identical to those of a hardware reset. The internal RAM is not affected and the special register assume the values shown in Table 3.
- As there are no precautions for protecting bit WDT from spurious writing in the IOCON register, special care must be taken when writing the program. In particular, the user should use the IOCON register bit handling instructions :
 - SETB and CLR x
in preference to the byte handling instructions :
 - MOV IOCON, # XXH, ORL IOCON, #XXH,
 - ANL IOCON, #XXH

External Counting in Power-down Mode (PD = PCON.1 = 1)

Table 3. Content of the SFRS after a reset triggered by the watchdog.

REGISTER	CONTENT
PC	000H
ACC	00H
B	00H
PSW	00H
SP	07H
DPTR	0000H
P0-P3	0FFH
IP	0X000000B
IE	0X000000B
TMOD	00H
TCON	00H
T2CON	00H
TH0	00H
TL0	00H
TH1	00H
TL1	00H
TH2	00H
TL2	00H
RCAP2H	00H
RCAP2L	00H
SCON	00H
SBUF	Indeterminate
IOCON	00H
PCON	000X0000B

- In the power-down mode, the oscillator is turned off and the 83C154's activity is frozen. However, if an external clock is connected to one of the two inputs, T1/T0, TIMER/COUNTERS 0 and 1 can continue to operate.
In this case, counting becomes asynchronous and the maximum, admissible frequency of the signal is $OSC : 24$.
- The overflow of either counter TF0 or TF1 causes an interrupt to be serviced or forces a reset if the counter is in the WATCHDOG MODE ($T32 = ICON.7 = 1$).

83C154 with Secret ROM

TEMIC offers 83C154 with the encrypted secret ROM option to secure the ROM code contained in the 83C154 microcontrollers.

The clear reading of the program contained in the ROM is made impossible due to an encryption through several random keys implemented during the manufacturing process.

The keys used to do such encryption are selected randomwise and are definitely different from one microcontroller to another.

This encryption is activated during the following phases :

- Everytime a byte is addressed during a verify of the ROM content, a byte of the encryption array is selected.
- MOVC instructions executed from external program memory are disabled when fetching code bytes from internal memory.
- EA is sampled and latched on reset, thus all state modification are disabled.

For further information please refer to the application note (ANM053) available upon request.

83C154 with Secret TAG

TEMIC offers special 64-bit identifier called "SECRET TAG" on the microcontroller chip.

The Secret Tag option is available on both ROMless and masked microcontrollers.

The Secret Tag feature allows serialization of each microcontroller for identification of a specific equipment. A unique number per device is implemented in the chip during manufacturing process. The serial number is a 64-bit binary value which is contained and addressable in the Special Function Registers (SFR) area.

This Secret Tag option can be read-out by a software routine and thus enables the user to do an individual identity check per device. This routine is implemented inside the microcontroller ROM memory in case of masked version which can be kept secret (and then the value of the Secret Tag also) by using a ROM Encryption.

For further information, please refer to the application note (ANM031) available upon request.

Electrical Characteristics

Absolute Maximum Ratings*

Ambiant Temperature Under Bias :

C = commercial	0°C to +70°C
I = industrial	-40°C to +85°C
Storage Temperature	-65°C to +150°C
Voltage on VCC to VSS	-0.5 V to +7 V
Voltage on Any Pin to VSS	-0.5 V to VCC + 0.5 V
Power Dissipation	1 W**

** This value is based on the maximum allowable die temperature and the thermal resistance of the package

* Notice

Stresses at or above those listed under " Absolute Maximum Ratings" may cause permanent damage to the device. This is a stress rating only and functional operation of the device at these or any other conditions above those indicated in the operational sections of this specification is not implied. Exposure to absolute maximum rating conditions may affect device reliability.

DC Parameters

TA = 0°C to 70°C ; Vcc = 0 V ; Vcc = 5 V ± 10 % ; F = 0 to 36 MHz

TA = -40°C + 85°C ; Vcc = 0 V ; Vcc = 5 V ± 10 % ; F = 0 to 36 MHz

SYMBOL	PARAMETER	MIN	MAX	UNIT	TEST CONDITIONS
VIL	Input Low Voltage	-0.5	0.2 Vcc - 0.1	V	
VIH	Input High Voltage (Except XTAL and RST)	0.2 Vcc + 1.4	Vcc + 0.5	V	
VIH1	Input High Voltage (for XTAL and RST)	0.7 Vcc	Vcc + 0.5	V	
VOL	Output Low Voltage (Port 1, 2 and 3)		0.3	V	IOL = 100 µA IOL = 1.6 mA (note 2) IOL = 3.5 mA
			0.45	V	
			1.0	V	
VOL1	Output Low Voltage (Port 0, ALE, PSEN)		0.3	V	IOL = 200 µA IOL = 3.2 mA (note 2) IOL = 7.0 mA
			0.45	V	
			1.0	V	
VOH	Output High Voltage Port 1, 2 and 3	Vcc - 0.3		V	IOH = - 10 µA
		Vcc - 0.7		V	IOH = - 30 µA
		Vcc - 1.5		V	IOH = - 60 µA VCC = 5 V ± 10 %
VOH1	Output High Voltage (Port 0, ALE, PSEN)	Vcc - 0.3		V	IOH = - 200 µA
		Vcc - 0.7		V	IOH = - 3.2 mA
		Vcc - 1.5		V	IOH = - 7.0 mA VCC = 5 V ± 10 %
IIL	Logical 0 Input Current (Ports 1, 2 and 3)		- 50	µA	Vin = 0.45 V
ILI	Input leakage Current		+/- 10	µA	0.45 < Vin < Vcc
ITL	Logical 1 to 0 Transition Current (Ports 1, 2 and 3)		- 650	µA	Vin = 2.0 V
IPD	Power Down Current		50	µA	Vcc = 2.0 V to 5.5 V (note 1)
RRST	RST Pulldown Resistor	50	200	KOhm	
CIO	Capacitance of I/O Buffer		10	pF	fc = 1 MHz, Ta = 25°C
ICC	Power Supply Current Freq = 1 MHz Icc op Icc idle Freq = 6 MHz Icc op Icc idle Freq ≥ 12 MHz Icc op = 1.3 Freq (MHz) + 4.5 mA Icc idle = 0.36 Freq (MHz) + 2.7 mA		1.8	mA	Vcc = 5.5 V
			1	mA	
			10	mA	
			4	mA	

Absolute Maximum Ratings*

Ambient Temperature Under Bias :

A = Automotive	-40°C to +125°C
Storage Temperature	-65°C to +150°C
Voltage on VCC to VSS	-0.5 V to +7 V
Voltage on Any Pin to VSS	-0.5 V to VCC + 0.5 V
Power Dissipation	1 W

** This value is based on the maximum allowable die temperature and the thermal resistance of the package

* Notice

Stresses at or above those listed under " Absolute Maximum Ratings" may cause permanent damage to the device. This is a stress rating only and functional operation of the device at these or any other conditions above those indicated in the operational sections of this specification is not implied. Exposure to absolute maximum rating conditions may affect device reliability.

DC Parameters

TA = -40°C + 125°C ; Vss = 0 V ; Vcc = 5 V ± 10 % ; F = 0 to 36 MHz

SYMBOL	PARAMETER	MIN	MAX	UNIT	TEST CONDITIONS	
VIL	Input Low Voltage	-0.5	0.2 Vcc - 0.1	V		
VIH	Input High Voltage (Except XTAL and RST)	0.2 Vcc + 1.4	Vcc + 0.5	V		
VIH1	Input High Voltage (for XTAL and RST)	0.7 Vcc	Vcc + 0.5	V		
VOL	Output Low Voltage (Port 1, 2 and 3)		0.3 0.45 1.0	V	IOL = 100 µA IOL = 1.6 mA (note 2) IOL = 3.5 mA	
VOL1	Output Low Voltage (Port 0, ALE, PSEN)		0.3 0.45 1.0	V	IOL = 200 µA IOL = 3.2 mA (note 2) IOL = 7.0 mA	
VOH	Output High Voltage Port 1, 2 and 3	Vcc - 0.3		V	IOH = - 10 µA	
		Vcc - 0.7		V	IOH = - 30 µA	
		Vcc - 1.5		V	IOH = - 60 µA VCC = 5 V ± 10 %	
VOH1	Output High Voltage (Port 0, ALE, PSEN)	Vcc - 0.3		V	IOH = - 200 µA	
		Vcc - 0.7		V	IOH = - 3.2 mA	
		Vcc - 1.5		V	IOH = - 7.0 mA VCC = 5 V ± 10 %	
IIL	Logical 0 Input Current (Ports 1, 2 and 3)		- 50	µA	Vin = 0.45 V	
ILI	Input leakage Current		±10	µA	0.45 < Vin < Vcc	
ITL	Logical 1 to 0 Transition Current (Ports 1, 2 and 3)		- 750	µA	Vin = 2.0 V	
IPD	Power Down Current		75	µA	Vcc = 2.0 V to 5.5 V (note 1)	
RRST	RST Pulldown Resistor	50	200	KOhm		
CIO	Capacitance of I/O Buffer		10	pF	fc = 1 MHz, Ta = 25°C	
ICC	Power Supply Current	Freq = 1 MHz	Icc op	1.8	mA	Vcc = 5.5 V
			Icc idle	1	mA	
			Icc op	10	mA	
			Icc idle	4	mA	
		Freq ≥ 12 MHz	Icc op = 1.3 Freq (MHz) + 4.5 mA			
			Icc idle = 0.36 Freq (MHz) + 2.7 mA			

Absolute Maximum Ratings*

Ambient Temperature Under Bias :

M = Military	-55°C to +125°C
Storage Temperature	-65°C to +150°C
Voltage on VCC to VSS	-0.5 V to +7 V
Voltage on Any Pin to VSS	-0.5 V to VCC + 0.5 V
Power Dissipation	1 W

** This value is based on the maximum allowable die temperature and the thermal resistance of the package

* Notice

Stresses at or above those listed under "Absolute Maximum Ratings" may cause permanent damage to the device. This is a stress rating only and functional operation of the device at these or any other conditions above those indicated in the operational sections of this specification is not implied. Exposure to absolute maximum rating conditions may affect device reliability.

DC Parameters

TA = -55°C + 125°C ; Vss = 0 V ; Vcc = 5 V ± 10 % ; F = 0 to 36 MHz

SYMBOL	PARAMETER	MIN	MAX	UNIT	TEST CONDITIONS	
VIL	Input Low Voltage	-0.5	0.2 Vcc - 0.1	V		
VIH	Input High Voltage (Except XTAL and RST)	0.2 Vcc + 1.4	Vcc + 0.5	V		
VIH1	Input High Voltage (for XTAL and RST)	0.7 Vcc	Vcc + 0.5	V		
VOL	Output Low Voltage (Port 1, 2 and 3)		0.45	V	IOL = 1.6 mA (note 2)	
VOL1	Output Low Voltage (Port 0, ALE, PSEN)		0.45	V	IOL = 3.2 mA (note 2)	
VOH	Output High Voltage (Port 1, 2, 3)	2.4		V	IOH = -60 µA Vcc = 5 V ± 10 %	
		0.75 Vcc		V	IOH = -25 µA	
		0.9 Vcc		V	IOH = -10 µA	
VOH1	Output High Voltage (Port 0 in External Bus Mode, ALE, PEN)	2.4		V	IOH = -400 µA Vcc = 5 V ± 10 %	
		0.75 Vcc		V	IOH = -150 µA	
		0.9 Vcc		V	IOH = -40 µA	
IIL	Logical 0 Input Current (Ports 1, 2 and 3)		-75	µA	Vin = 0.45 V	
ILI	Input leakage Current		±10	µA	0.45 < Vin < Vcc	
ITL	Logical 1 to 0 Transition Current (Ports 1, 2 and 3)		-750	µA	Vin = 2.0 V	
IPD	Power Down Current		75	µA	Vcc = 2.0 V to 5.5 V (note 1)	
RRST	RST Pulldown Resistor	50	200	KOhm		
CIO	Capacitance of I/O Buffer		10	pF	fc = 1 MHz, Ta = 25°C	
ICC	Power Supply Current	Freq = 1 MHz	Icc op	1.8	mA	Vcc = 5.5 V
			Icc idle	1	mA	
		Freq = 6 MHz	Icc op	10	mA	
			Icc idle	4	mA	
		Freq ≥ 12 MHz	Icc op = 1.3 Freq (MHz) + 4.5 mA Icc idle = 0.36 Freq (MHz) + 2.7 mA			

Absolute Maximum Ratings*

Ambient Temperature Under Bias :

C = Commercial 0°C to +70°C

I = Industrial -40°C to 85°C

Storage Temperature -65°C to + 150°C

Voltage on VCC to VSS -0.5 V to + 7 V

Voltage on Any Pin to VSS -0.5 V to VCC + 0.5 V

Power Dissipation 1 W

** This value is based on the maximum allowable die temperature and the thermal resistance of the package

* Notice

Stresses at or above those listed under " Absolute Maximum Ratings" may cause permanent damage to the device. This is a stress rating only and functional operation of the device at these or any other conditions above those indicated in the operational sections of this specification is not implied. Exposure to absolute maximum rating conditions may affect device reliability.

DC Parameters

TA = 0°C to 70°C ; Vcc = 2.7 V to 5.5 V ; Vss = 0 V ; F = 0 to 16 MHz

TA = -40°C to 85°C ; Vcc = 2.7 V to 5.5 V

SYMBOL	PARAMETER	MIN	MAX	UNIT	TEST CONDITIONS
VIL	Input Low Voltage	-0.5	0.2 VCC - 0.1	V	
VIH	Input High Voltage (Except XTAL and RST)	0.2 VCC + 1.4 V	VCC + 0.5	V	
VIH1	Input High Voltage to XTAL1	0.7 VCC	VCC + 0.5	V	
VIH2	Input High Voltage to RST for Reset	0.7 VCC	VCC + 0.5	V	
VPD	Power Down Voltage to Vcc in PD Mode	2.0	6.0	V	
VOL	Output Low Voltage (Ports 1, 2, 3)		0.45	V	IOL = 0.8 mA (note 2)
VOL1	Output Low Voltage Port 0, ALE, PSEN		0.45	V	IOL = 1.6 mA (note 2)
VOH	Output High Voltage Ports 1, 2, 3	0.9 Vcc		V	IOH = - 10 µA
VOH1	Output High Voltage (Port 0 in External Bus Mode), ALE, PSEN	0.9 Vcc		V	IOH = - 40 µA
IIL	Logical 0 Input Current Ports 1, 2, 3		- 50	µA	Vin = 0.45 V
ILI	Input Leakage Current		± 10	µA	0.45 < Vin < VCC
ITL	Logical 1 to 0 Transition Current (Ports 1, 2, 3)		- 650	µA	Vin = 2.0 V
IPD	Power Down Current		50	µA	VCC = 2 V to 5.5 V (note 1)
RRST	RST Pulldown Resistor	50	200	kΩ	
CIO	Capacitance of I/O Buffer		10	pF	fc = 1 MHz, TA = 25°C

Maximum Icc (mA)

FREQUENCY/Vcc	OPERATING (NOTE 1)				IDLE (NOTE 1)			
	2.7 V	3 V	3.3 V	5.5 V	2.7 V	3 V	3.3 V	5.5 V
1 MHz	0.8 mA	1 mA	1.1 mA	1.8 mA	400 µA	500 µA	600 µA	1 mA
6 MHz	4 mA	5 mA	6 mA	10 mA	1.5 mA	1.7 mA	2 mA	4 mA
12 MHz	8 mA	10 mA	12 mA		2.5 mA	3 mA	3.5 mA	
16 MHz	10 mA	12 mA	14 mA		3 mA	3.8 mA	4.5 mA	

Freq > 12 MHz (Vcc = 5.5 V) Icc (mA) = 1.3 × Freq (MHz) + 4.5
 Icc Idle (mA) = 0.36 × Freq (MHz) + 2.7

Note 1 : ICC is measured with all output pins disconnected; XTAL1 driven with TCLCH, TCHCL = 5 ns, VIL = VSS + .5 V, VIH = VCC - .5 V; XTAL2 N.C.; EA = RST = Port 0 = VCC. ICC would be slightly higher if a crystal oscillator used.

Idle ICC is measured with all output pins disconnected; XTAL1 driven with TCLCH, TCHCL = 5 ns, VIL = VSS + 5 V, VIH = VCC - .5 V; XTAL2 N.C.; Port 0 = VCC; EA = RST = VSS.

Power Down ICC is measured with all output pins disconnected; EA = PORT 0 = VCC; XTAL2 N.C.; RST = VSS.

Note 2 : Capacitance loading on Ports 0 and 2 may cause spurious noise pulses to be superimposed on the VOLS of ALE and Ports 1 and 3. The noise is due to external bus capacitance discharging into the Port 0 and Port 2 pins when these pins make 1 to 0 transitions during bus operations. In the worst cases (capacitive loading 100 pF), the noise pulse on the ALE line may exceed 0.45 V with maxi VOL peak 0.6 V A Schmitt Trigger use is not necessary.

Figure 15. ICC Test Condition, Idle Mode.
All other pins are disconnected.

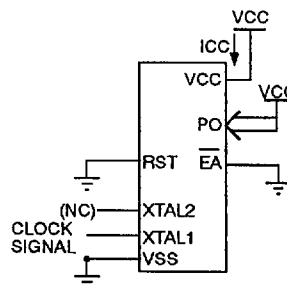

Figure 16. ICC Test Condition, Active Mode.
All other pins are disconnected.

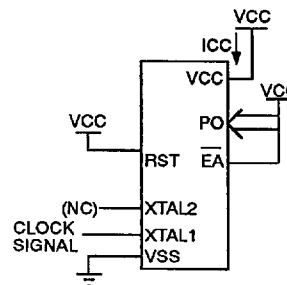

Figure 17. ICC Test Condition, Power Down Mode.
All other pins are disconnected.

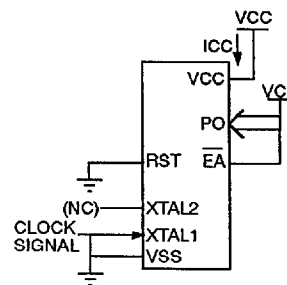
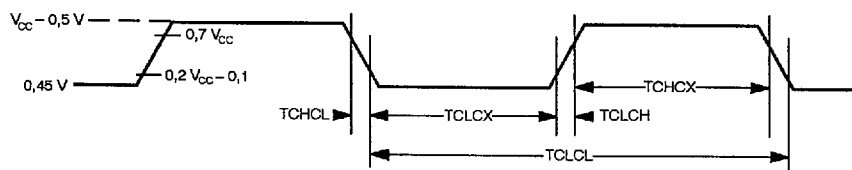

Figure 18. Clock Signal Waveform for ICC Tests in Active and Idle Modes. TCLCH = TCHCL = 5 ns.



Explanation of the AC Symbol

Each timing symbol has 5 characters. The first character is always a "T" (stands for time). The other characters, depending on their positions, stand for the name of a signal or the logical status of that signal. The following is a list of all the characters and what they stand for.

Example :

TAVLL = Time for Address Valid to ALE low.

TLLPL = Time for ALE low to $\overline{\text{PSEN}}$ low.

A : Address.
 C : Clock.
 D : Input data.
 H : Logic level HIGH
 I : Instruction (program memory contents).
 L : Logic level LOW, or ALE.
 P : PSEN.

Q : Output data.
 R : READ signal.
 T : Time.
 V : Valid.
 W : WRITE signal.
 X : No longer a valid logic level.
 Z : Float.

AC Parameters

TA = 0 to +70°C ; Vss = 0 V ; Vcc = 5 V ± 10 % ; F = 0 to 36 MHz

TA = -55° + 125°C ; Vss = 0 V ; 2.7 V < Vcc < 5.5 V ; F = 0 to 16 MHz

TA = -55° + 125°C ; Vss = 0 V ; Vcc = 5 V ± 10 % ; F = 0 to 36 MHz

(Load Capacitance for PORT 0, ALE and PSEN = 100 pF ; Load Capacitance for all other outputs = 80 pF)

External Program Memory Characteristics

SYMBOL	PARAMETER	16 MHz		20 MHz		25 MHz		30 MHz		36 MHz	
		MIN	MAX	MIN	MAX	MIN	MAX	MIN	MAX	MIN	MAX
TLHLL	ALE Pulse Width	110		90		70		60		50	
TAVLL	Address valid to ALE	40		30		20		15		10	
TLLAX	Address Hold After ALE	35		35		35		35		35	
TLLIV	ALE to valid instr in		185		170		130		100		80
TLLPL	ALE to PSEN	45		40		30		25		20	
TPLPH	PSEN pulse Width	165		130		100		80		75	
TPLIV	PSEN to valid instr in		125		110		85		65		50
TPXIX	Input instr Hold After PSEN	0		0		0		0		0	
TPXIZ	Input instr Float After PSEN		50		45		35		30		25
TPXAV	PSEN to Address Valid	55		50		40		35		30	
TAVIV	Address to Valid instr in		230		210		170		130		90
TPLAZ	PSEN low to Address Float		10		10		8		6		5

External Program Memory Read Cycle

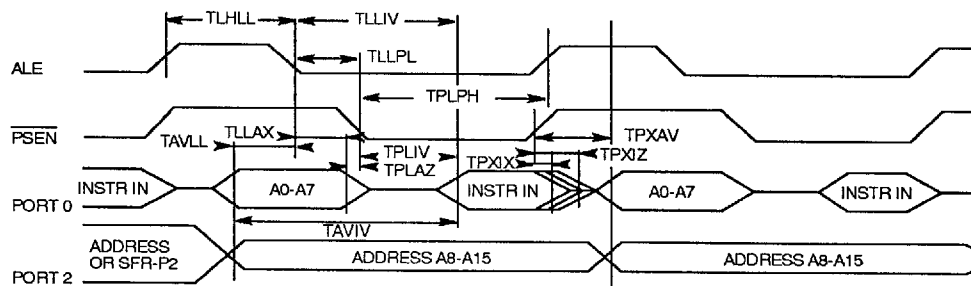

External Data Memory Characteristics

SYMBOL	PARAMETER	16 MHz		20 MHz		25 MHz		30 MHz		36 MHz	
		MIN	MAX	MIN	MAX	MIN	MAX	MIN	MAX	MIN	MAX
TRLRH	RD pulse Width	340		270		210		180		120	
TWLWH	WR pulse Width	340		270		210		180		120	
TLLAX	Address Hold After ALE	85		85		70		55		35	
TRLDV	RD to Valid in		240		210		175		135		110
TRHDX	Data hold after RD	0		0		0		0		0	
TRHDZ	Data float after RD		90		90		80		70		50
TLLDV	ALE to Valid Data In		435		370		350		235		170
TAVDV	Address to Valid Data IN		480		400		300		260		190
TLLWL	ALE to WR or RD	150	250	135	170	120	130	90	115	70	100
TAVWL	Address to WR or RD	180		180		140		115		75	
TQVWX	Data valid to WR transition	35		35		30		20		15	
TQVWH	Data Setup to WR transition	380		325		250		215		170	
TWHQX	Data Hold after WR	40		35		30		20		15	
TRLAZ	RD low to Address Float		0		0		0		0		0
TWHLH	RD or WR high to ALE high	35	90	35	60	25	45	20	40	20	40

External Data Memory Write Cycle

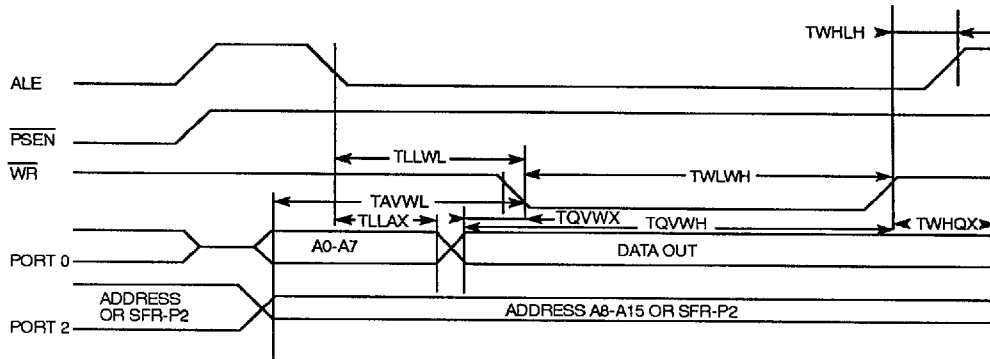

External Data Memory Read Cycle

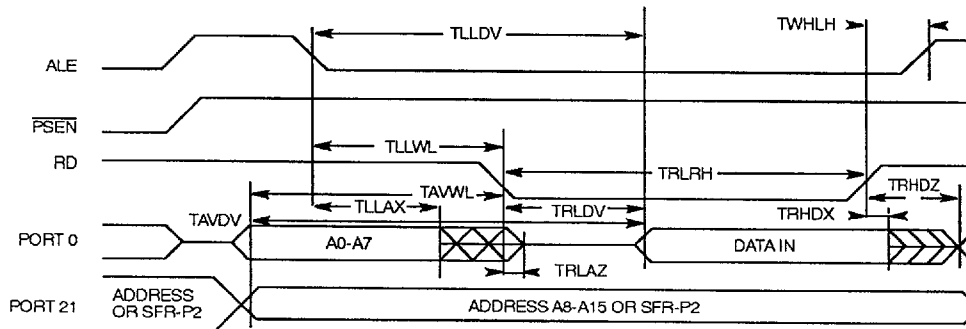

Serial Port Timing – Shift Register Mode

SYMBOL	PARAMETER	16 MHz		20 MHz		25 MHz		30 MHz		36 MHz	
		MIN	MAX	MIN	MAX	MIN	MAX	MIN	MAX	MIN	MAX
TXLXL	Serial Port Clock Cycle Time	750		600		480		400		330	
TQVXH	Output Data Setup to Clock Rising Edge	563		480		380		300		220	
TXHQX	Output Data Hold after Clock Rising Edge	63		90		65		50		45	
TXHDX	Input Data Hold after Clock Rising Edge	0		0		0		0		0	
TXHDV	Clock Rising Edge to Input Data Valid		563		450		350		300		250

Shift Register Timing Waveforms

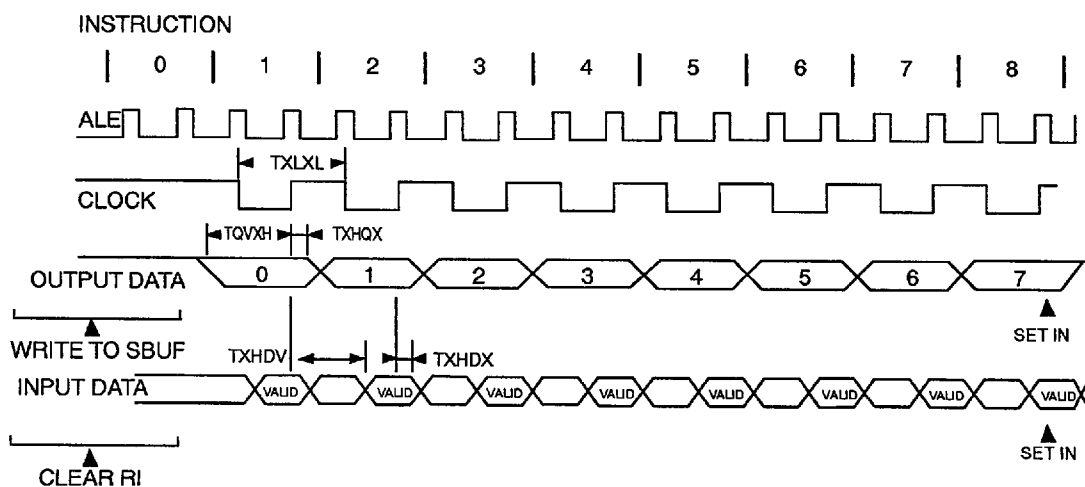

External Clock Drive Characteristics (XTAL1)

SYMBOL	PARAMETER	MIN	MAX	UNIT
FCLCL	Oscillator Frequency		36	MHz
TCLCL	Oscillator period	27.8		ns
TCHCX	High Time	5		ns
TCLCX	Low Time	5		ns
TCLCH	Rise Time		5	ns
TCHCL	Fall Time		5	ns

External Clock Drive Waveforms

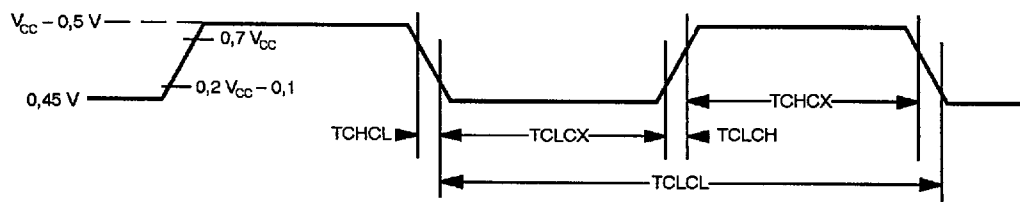

AC Testing Input/Output Waveforms

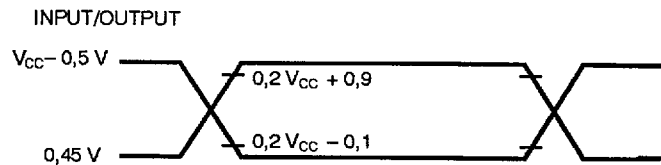

AC inputs during testing are driven at $V_{CC} - 0.5$ for a logic "1" and $0.45 V$ for a logic "0". Timing measurements are made at $V_{IH \text{ min}}$ for a logic "1" and $V_{IL \text{ max}}$ for a logic "0".

Float Waveforms

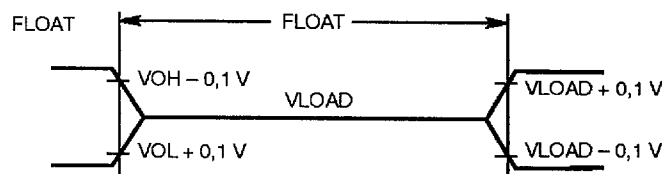

For timing purposes as port pin is no longer floating when a $100 mV$ change from load voltage occurs and begins to float when a $100 mV$ change from the loaded VOH/VOL level occurs. $I_{OL}/I_{OH} \geq \pm 20 mA$.

Clock Waveforms

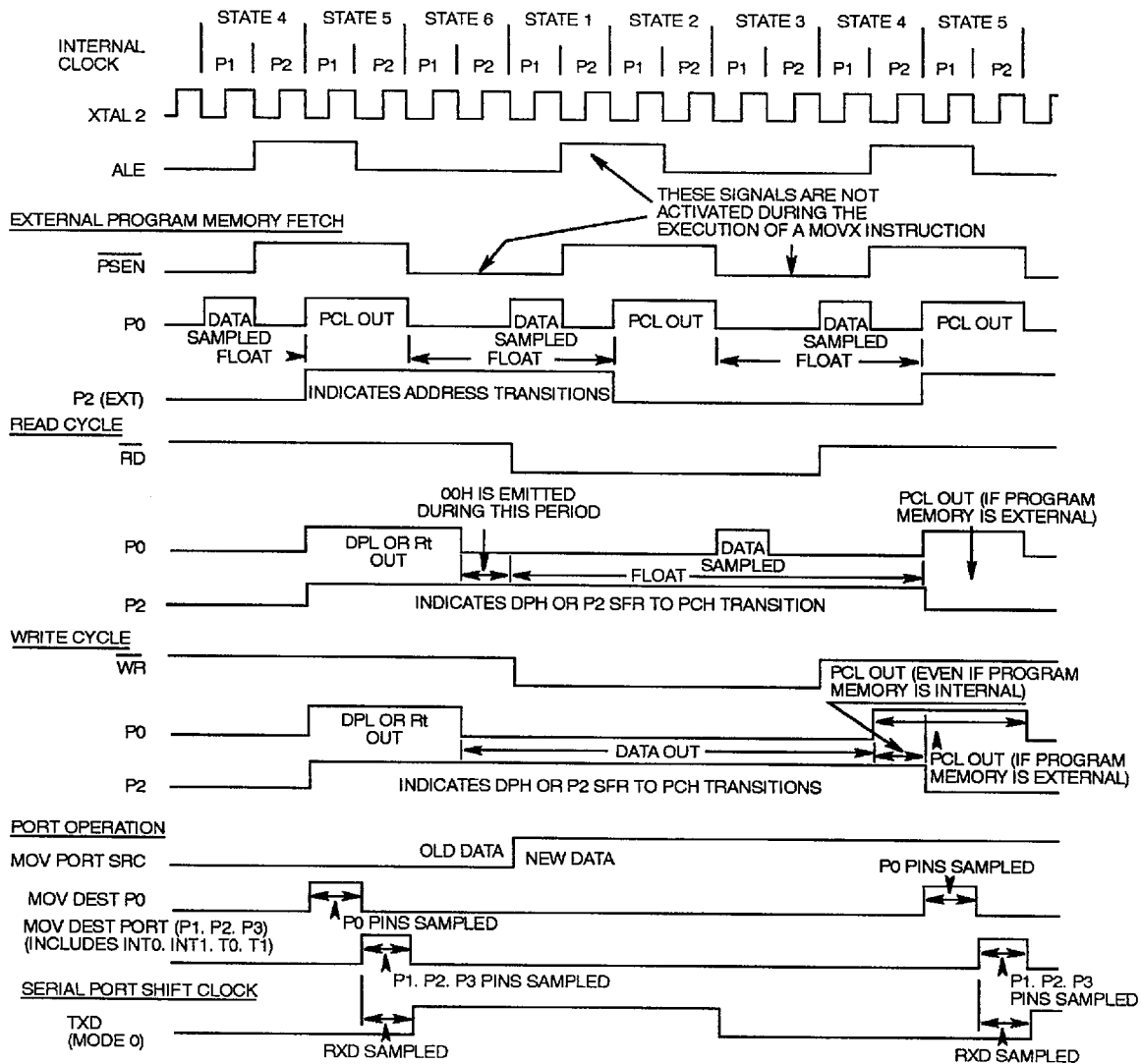

This diagram indicates when signals are clocked internally. The time it takes the signals to propagate to the pins, however, ranges from 25 to 125 ns. This propagation delay is dependent on variables such as temperature and pin loading. Propagation also varies from output to output and component. Typically though ($T_A = 25^\circ\text{C}$ fully loaded) RD and WR propagation delays are approximately 50 ns. The other signals are typically 85 ns. Propagation delays are incorporated in the AC specifications.

Ordering Information

