



REF-02

+5V PRECISION VOLTAGE
REFERENCE/TEMPERATURE TRANSDUCER

Precision Monolithics Inc.

FEATURES

- 5 Volt Output $\pm 0.3\%$ Max
- Temperature Voltage Output $2.1\text{mV}/^\circ\text{C}$
- Adjustment Range $\pm 3\%$ Min
- Excellent Temperature Stability $8.5\text{ppm}/^\circ\text{C}$ Max
- Low Noise $15\mu\text{V}_{\text{p-p}}$ Max
- Low Supply Current 1.4mA Max
- Wide Input Voltage Range 7V to 40V
- High Load-Driving Capability 20mA
- No External Components
- Short-Circuit Proof
- MIL-STD-883 Screening Available
- Available in Die Form

ORDERING INFORMATION [†]

$T_A = 25^\circ\text{C}$ $V_{OS\text{ MAX}}$ (mV)	PACKAGE				OPERATING TEMPERATURE RANGE
	TO-99	CERDIP 8-PIN	PLASTIC 8-PIN	LCC 20-CONTACT	
± 15	REF02AJ*	REF02AZ*	-	-	MIL
± 15	REF02EJ	REF02EZ	-	-	COM
± 25	REF02J*	REF02Z*	-	REF02RC/883	MIL
± 25	REF02HJ	REF02HZ	REF02HP	-	COM
± 50	REF02CJ	REF02CZ	-	-	COM
± 50	-	-	REF02CP	-	XIND
± 50	-	-	REF02CS††	-	XIND
± 100	REF02DJ	REF02DZ	REF02DP	-	COM

* For devices processed in total compliance to MIL-STD-883, add /883 after part number. Consult factory for 883 data sheet.

† Burn-in is available on commercial and industrial temperature range parts in CerDIP, plastic DIP, and TO-can packages. For ordering information, see 1990/91 Data Book, Section 2.

†† For availability and burn-in information on SO and PLCC packages, contact your local sales office.

GENERAL DESCRIPTION

The REF-02 precision voltage reference provides a stable +5V output which can be adjusted over a $\pm 6\%$ range with minimal effect on temperature stability. Single-supply operation over an input voltage range of 7V to 40V, low current drain of 1mA, and excellent temperature stability are achieved with an improved bandgap design. Low cost, low noise, and low power make the REF-02 an excellent choice whenever a stable voltage reference is required. Applications include D/A and A/D converters, portable instrumentation, and digital voltmeters. The versatility of the REF-02 is enhanced by its use as a monolithic temperature transducer. For +10V references, see the REF-01 and REF-10 data sheets.

PIN CONNECTIONS

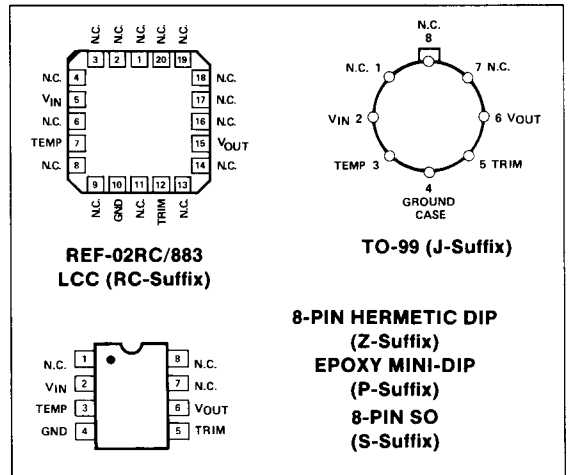

SIMPLIFIED SCHEMATIC

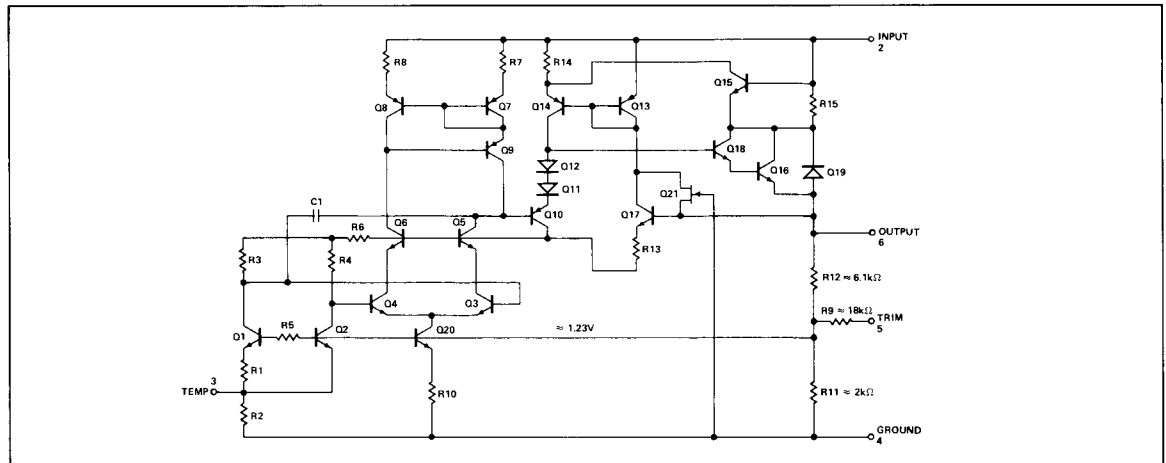

ABSOLUTE MAXIMUM RATINGS (Note 1)

Input Voltage	
REF-02A, E, H, RC, All DICE	40V
REF-02C, D	30V
Output Short-Circuit Duration (to Ground or V_{IN})	Indefinite
Storage Temperature Range	
J, RC, and Z Packages	-65°C to +150°C
P Package	-65°C to +125°C
Operating Temperature Range	
REF-02A, REF-02, REF-02RC	-65°C to +125°C
REF-02E, REF-02H	0°C to +70°C
REF-02CJ, CZ, REF-02D	0°C to +70°C
REF-02CP, CS	-40°C to +85°C
Lead Temperature (Soldering, 60 sec)	300°C

 Junction Temperature (T_J) -65°C to +150°C

PACKAGE TYPE	θ_{JA} (NOTE 2)	θ_{JC}	UNITS
TO-99 (J)	170	24	°C/W
8-Pin Hermetic DIP (Z)	162	26	°C/W
8-Pin Plastic DIP (P)	110	50	°C/W
20-Contact LCC (RC, TC)	120	40	°C/W
8-Pin SO (S)	160	44	°C/W
20-Contact PLCC (PC)	80	39	°C/W

NOTES:

- Absolute maximum ratings apply to both DICE and packaged parts, unless otherwise noted.
- θ_{JA} is specified for worst case mounting conditions, i.e., θ_{JA} is specified for device in socket for TO, CerDIP, P-DIP, and LCC packages; θ_{JA} is specified for device soldered to printed circuit board for SO and PLCC packages.

ELECTRICAL CHARACTERISTICS at $V_{IN} = +15V$, $T_A = +25^\circ C$, unless otherwise noted.

PARAMETER	SYMBOL	CONDITIONS	REF-02A/E			REF-02/H			UNITS
			MIN	TYP	MAX	MIN	TYP	MAX	
Output Voltage	V_O	$I_L = 0$	4.985	5.000	5.015	4.975	5.000	5.025	V
Output Adjustment Range	ΔV_{trim}	$R_p = 10k\Omega$	± 3	± 6	—	± 3	± 6	—	%
Output Voltage Noise	e_{np-p}	0.1Hz to 10Hz (Note 7)	—	10	15	—	10	15	μV_{p-p}
Line Regulation (Note 2)		$V_{IN} = 8V$ to 33V	—	0.006	0.010	—	0.006	0.010	%/V
Load Regulation (Note 2)		$I_L = 0$ to 10mA	—	0.005	0.010	—	0.006	0.010	%/mA
Turn-on Settling Time	t_{ON}	To $\pm 0.1\%$ of final value	—	5	—	—	5	—	μs
Quiescent Supply Current	I_{SY}	No Load	—	1.0	1.4	—	1.0	1.4	mA
Load Current	I_L		10	21	—	10	21	—	mA
Sink Current	I_S	(Note 8)	-0.3	-0.5	—	-0.3	-0.5	—	mA
Short-Circuit Current	I_{SC}	$V_O = 0$	—	30	—	—	30	—	mA
Temperature Voltage Output	V_T	(Note 3)	—	630	—	—	630	—	mV

ELECTRICAL CHARACTERISTICS at $V_{IN} = +15V$, $-55^\circ C \leq T_A \leq \pm 125^\circ C$ for REF-02A and REF-02, $0^\circ C \leq T_A \leq +70^\circ C$ for REF-02E and REF-02H, $I_L = 0mA$, unless otherwise noted.

PARAMETER	SYMBOL	CONDITIONS	REF-02A/E			REF-02/H			UNITS
			MIN	TYP	MAX	MIN	TYP	MAX	
Output Voltage Change with Temperature (Notes 4, 5)	ΔV_{OT}	$0^\circ C \leq T_A \leq +70^\circ C$ $-55^\circ C \leq T_A \leq +125^\circ C$	—	0.02	0.06	—	0.07	0.17	%
Output Voltage Temperature Coefficient	TCV_O	(Note 6)	—	3	8.5	—	10	25	ppm/°C
Change in V_O Temperature Coefficient with Output Adjustment		$R_p = 10k\Omega$	—	0.7	—	—	0.7	—	ppm/%
Line Regulation ($V_{IN} = 8$ to 33V) (Note 2)		$0^\circ C \leq T_A \leq +70^\circ C$ $-55^\circ C \leq T_A \leq +125^\circ C$	—	0.007	0.012	—	0.007	0.012	%/V
Load Regulation ($I_L = 0$ to 8mA) (Note 2)		$0^\circ C \leq T_A \leq +70^\circ C$ $-55^\circ C \leq T_A \leq +125^\circ C$	—	0.006	0.010	—	0.007	0.012	%/mA
Temperature Voltage Output Temperature Coefficient	TCV_T	(Note 3)	—	2.1	—	—	2.1	—	mV/°C

NOTES:

- Guaranteed by design.
- Line and Load Regulation specifications include the effect of self heating.
- Limit current in or out of pin 3 to 50mA and capacitance on pin 3 to 30pF.
- ΔV_{OT} is defined as the absolute difference between the maximum output voltage and the minimum output voltage over the specified temperature range expressed as a percentage of 5V.
- ΔV_{OT} specification applies trimmed to +5.000V or untrimmed.
- TCV_O is defined as ΔV_{OT} divided by the temperature range, i.e.,

$$TCV_O = \frac{\Delta V_{OT}}{70^\circ C}$$

- Sample Tested.
- During sink current test the driver meets the output voltage specified.

$$\Delta V_{OT} = \left| \frac{V_{MAX} - V_{MIN}}{5V} \right| \times 100$$

ELECTRICAL CHARACTERISTICS at $V_{IN} = +15V$, $T_A = 25^\circ C$, unless otherwise noted.

PARAMETER	SYMBOL	CONDITIONS	REF-02C			REF-02D			UNITS
			MIN	TYP	MAX	MIN	TYP	MAX	
Output Voltage	V_O	$I_L = 0mA$	4.950	5.000	5.050	4.900	5.000	5.100	V
Output Adjustment Range	ΔV_{trim}	$R_p = 10k\Omega$	± 2.7	± 6.0	—	± 2.0	± 6.0	—	%
Output Voltage Noise	e_{np-p}	0.1Hz to 10Hz (Note 7)	—	12	18	—	12	—	μV_{p-p}
Line Regulation (Note 2)		$V_{IN} = 8V$ to $30V$	—	0.009	0.015	—	0.010	0.04	%/V
Load Regulation (Note 2)		$I_L = 0$ to $8mA$ $I_L = 0$ to $4mA$	—	0.006	0.015	—	—	—	%/mA
Turn-on Settling Time	t_{ON}	To $\pm 0.1\%$ of final value	—	5	—	—	5	—	μs
Quiescent Supply Current	I_{SY}	No Load	—	1.0	1.6	—	1.0	2.0	mA
Load Current	I_L		8	21	—	8	21	—	mA
Sink Current	I_S	Note 8	-0.3	-0.5	—	-0.3	-0.5	—	mA
Short-Circuit Current	I_{SC}	$V_O = 0$	—	30	—	—	30	—	mA
Temperature Voltage Output	V_T	(Note 3)	—	630	—	—	630	—	mV

ELECTRICAL CHARACTERISTICS at $V_{IN} = +15V$; $I_L = 0mA$, $0^\circ C \leq T_A \leq +70^\circ C$ for REF-02CJ, CZ, DJ, DZ, DP; $-40^\circ C \leq T_A \leq +85^\circ C$ for REF-02CP, CS; unless otherwise noted.

PARAMETER	SYMBOL	CONDITIONS	REF-02C			REF-02D			UNITS
			MIN	TYP	MAX	MIN	TYP	MAX	
Output Voltage Change with Temperature	ΔV_{OT}	(Notes 4 and 5)	—	0.14	0.45	—	0.49	1.7	%
Output Voltage Temperature Coefficient	TCV_O	(Note 6)	—	20	65	—	70	250	ppm/ $^\circ C$
Change in V_O Temperature Coefficient With Output Adjustment		$R_p = 10k\Omega$	—	0.7	—	—	0.7	—	ppm/%
Line Regulation (Note 2)		$V_{IN} = 8V$ to $30V$	—	0.011	0.018	—	0.012	0.05	%/V
Load Regulation (Note 2)		$I_L = 0$ to $5mA$	—	0.008	0.018	—	0.016	0.05	%/mA
Temperature Voltage Output Temperature Coefficient	TCV_T	(Note 3)	—	2.1	—	—	2.1	—	mV/ $^\circ C$

NOTES:

- Guaranteed by design.
- Line and Load Regulation specifications include the effect of self heating.
- Limit current in or out of pin 3 to 50mA and capacitance on pin 3 to 30pF.
- ΔV_{OT} is defined as the absolute difference between the maximum output voltage and the minimum output voltage over the specified temperature range expressed as a percentage of 5V.

$$\Delta V_{OT} = \left| \frac{V_{MAX} - V_{MIN}}{5V} \right| \times 100$$

- ΔV_{OT} specification applies trimmed to +5.000V or untrimmed.
- TCV_O is defined as ΔV_{OT} divided by the temperature range, i.e.,

$$TCV_O = \frac{\Delta V_{OT}}{70^\circ C}$$

- Sample Tested.
- During sink current test the device meets the output voltage specified.

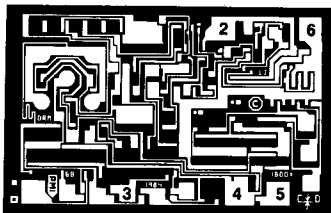
DICE CHARACTERISTICS (125°C TESTED DICE AVAILABLE)

DIE SIZE 0.074 × 0.048 inch, 3552 sq. mils
(1.88 × 1.22 mm, 2.29 sq. mm)

2. INPUT VOLTAGE (V_{IN})
3. TEMPERATURE TRANSDUCER OUTPUT VOLTAGE (TEMP)
4. GROUND
5. TRIM
6. OUTPUT VOLTAGE (V_{OUT})

For additional DICE ordering information, refer to 1990/91 Data Book, Section 2.

WAFER TEST LIMITS at $V_{IN} = +15V$, $T_A = 25^\circ C$ for REF-02N and REF-02G devices; $T_A = 125^\circ C$ for REF-02NT and REF-02GT devices, unless otherwise noted. (Note 3)

PARAMETER	SYMBOL	CONDITIONS	REF-02NT LIMIT	REF-02N LIMIT	REF-02GT LIMIT	REF-02G LIMIT	UNITS
Output Voltage	V_O	$I_L = 0$	4.975	4.985	4.950	4.975	V MIN
			5.025	5.015	5.050	5.025	V MAX
Output Adjustment Range	V_{trim}	$R_p = 10k\Omega$	—	±3	—	±3	% MIN
Line Regulation		$V_{IN} = 8V$ to $33V$	0.015	0.01	0.015	0.01	%/V MAX

NOTE:

Electrical tests are performed at wafer probe to the limits shown. Due to variations in assembly methods and normal yield loss, yield after packaging is not guaranteed for standard product dice. Consult factory to negotiate specifications based on dice lot qualification through sample lot assembly and testing.

TYPICAL ELECTRICAL CHARACTERISTICS at $V_{IN} = +15V$, $T_A = +25^\circ C$, unless otherwise noted.

PARAMETER	SYMBOL	CONDITIONS	REF-02NT TYPICAL	REF-02N TYPICAL	REF-02GT TYPICAL	REF-02G TYPICAL	UNITS
Temp. Voltage Output	V_T	(Notes 1, 2)	630	630	630	630	mV
Temp. Voltage Output Temp. Coefficient	TCV_T	(Notes 1, 2)	2.1	2.1	2.1	2.1	mV/°C
Output Voltage Temp. Coefficient	TCV_O		10	10	10	10	ppm/°C
Load Regulation		$I_L = 0$ to $10mA$ $I_L = 0$ to $8mA$, NT, GT @ $+125^\circ C$	0.007	0.005	0.009	0.006	%/mA
Output Voltage Noise	e_{np-p}	0.1Hz to 10Hz	10	10	10	10	μV_{p-p}
Turn-On Settling Time	t_{ON}	To $\pm 0.1\%$ of final value, NT, GT @ $+125^\circ C$	7.5	5.0	7.5	5.0	μs
Quiescent Supply Current	I_{SY}	No Load, NT, GT @ $+125^\circ C$	1.4	1.0	1.4	1.0	mA
Load Current	I_L		21	21	21	21	mA
Sink Current	I_S		-0.5	-0.5	-0.5	-0.5	mA
Short-Circuit Current	I_{SC}	$V_O = 0$	30	30	30	30	mA

NOTES:

1. See AN-18 for detailed REF-02 thermometer applications information.
2. Limit current in or out of pin 3 to 50nA and capacitance on pin 3 to 30pF.
3. For $+25^\circ C$ specifications of REF-02NT and REF-02GT, see REF-02N and REF-02G respectively.

OUTPUT ADJUSTMENT

The REF-02 trim terminal can be used to adjust the output voltage over a $5V \pm 300mV$ range. This feature allows the system designer to trim system errors by setting the reference to a voltage other than 5V. Of course, the output can also be set to exactly 5.000V or to 5.12V for binary applications.

Adjustment of the output does not significantly affect the temperature performance of the device. Typically, the temperature coefficient change is $0.7ppm/^{\circ}C$ for 100mV of output adjustment.

OUTPUT ADJUSTMENT CIRCUIT

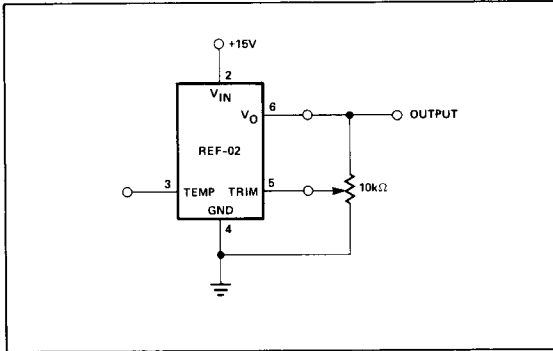

BURN-IN CIRCUIT

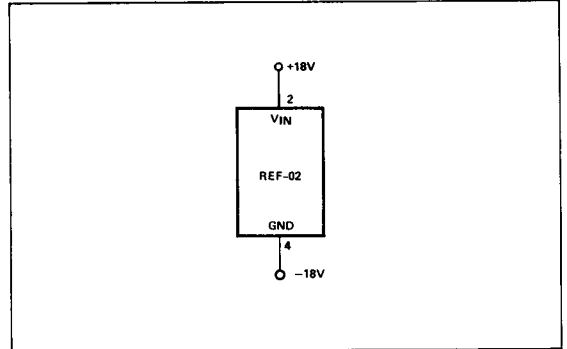

TYPICAL PERFORMANCE CHARACTERISTICS

OUTPUT WIDEBAND NOISE vs BANDWIDTH (0.1Hz TO FREQUENCY INDICATED)

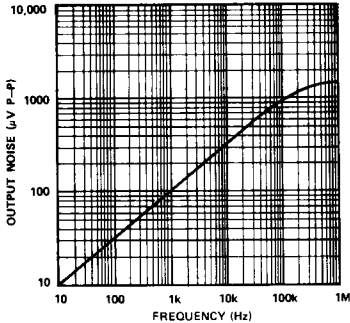

LINE REGULATION vs FREQUENCY

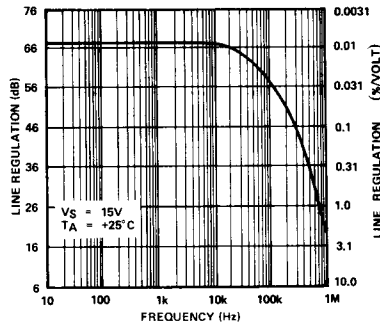

OUTPUT CHANGE DUE TO THERMAL SHOCK

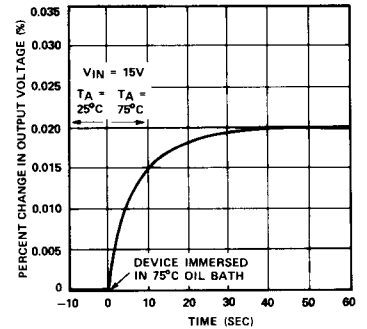

TYPICAL PERFORMANCE CHARACTERISTICS

MAXIMUM LOAD CURRENT vs INPUT VOLTAGE

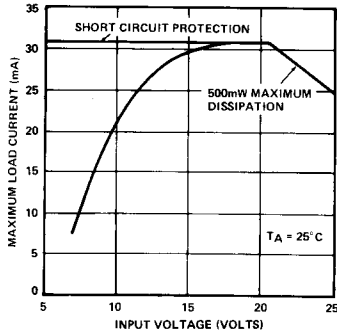
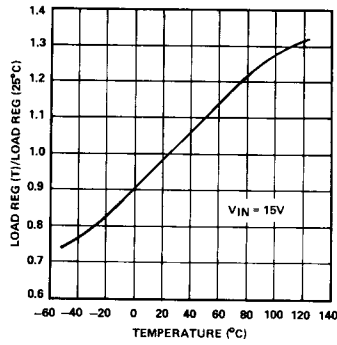
 NORMALIZED LOAD REGULATION ($\Delta I_L = 10\text{mA}$) vs TEMPERATURE

NORMALIZED LINE REGULATION vs TEMPERATURE

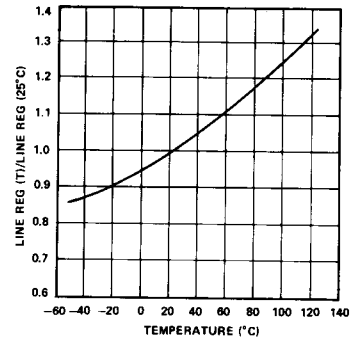

LINE REGULATION vs SUPPLY VOLTAGE

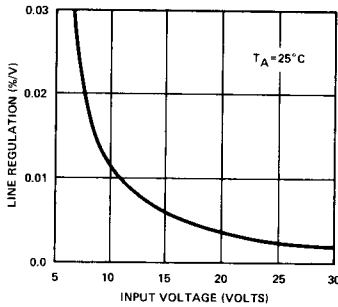

MAXIMUM LOAD CURRENT vs TEMPERATURE

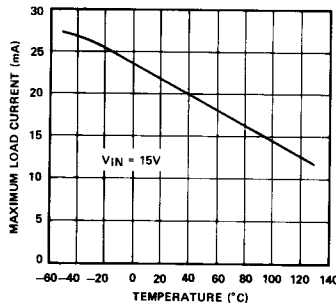

QUIESCENT CURRENT vs TEMPERATURE

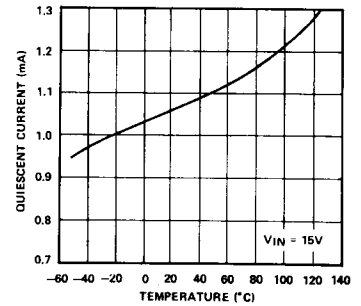

TYPICAL APPLICATIONS

±5V REFERENCE

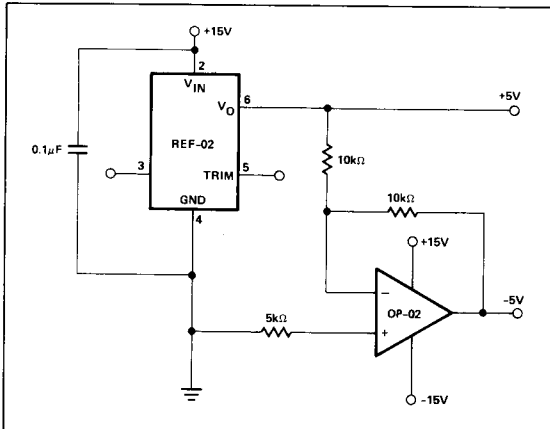

±2.5V REFERENCE

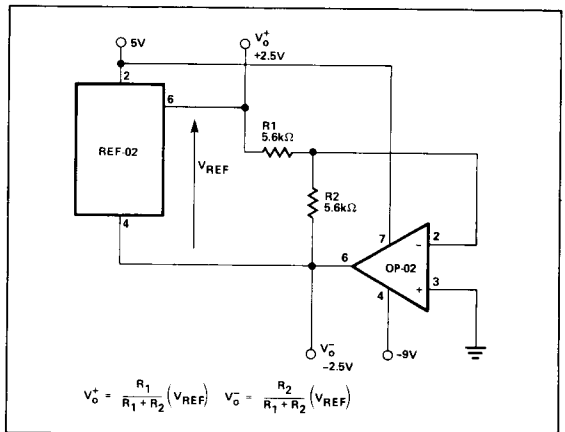

10

VOLTAGE REFERENCES

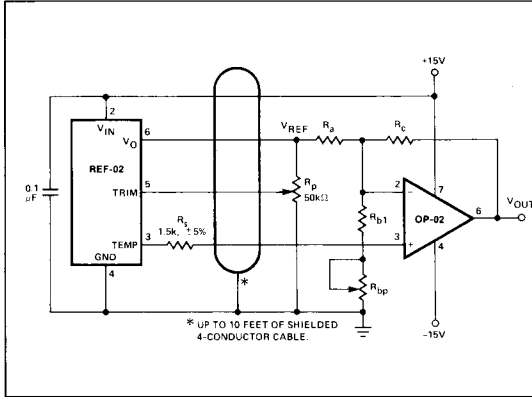
PRECISION TEMPERATURE TRANSDUCER WITH REMOTE SENSOR

RESISTOR VALUES

TCV _{OUT} SLOPE (S)	10mV/°C	100mV/°C	10mV/°F
TEMPERATURE RANGE	-55° C to +125° C	-55° C to +125° C	-67° F to +257° C
OUTPUT VOLTAGE RANGE	-0.55V to +1.25V	-5.5V to +12.5V*	-0.67V to +2.57V
ZERO-SCALE	0V @ 0° C	0V @ 0° C	0V @ 0° F
R _a (± 1% resistor)	9.09kΩ	15kΩ	7.5kΩ
R _{b1} (± 1% resistor)	1.5kΩ	1.82kΩ	1.21kΩ
R _{bp} (Potentiometer)	200Ω	500Ω	200Ω
R _c (± 1% resistor)	5.11kΩ	84.5kΩ	8.25kΩ

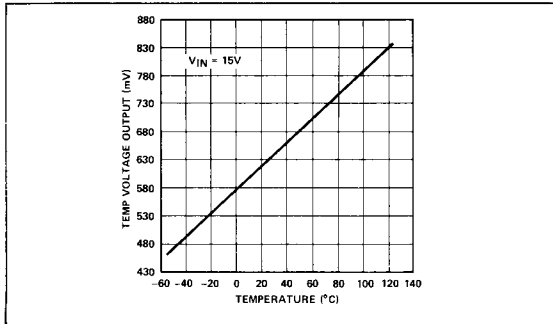
*For 125° C operation, the op amp output must be able to swing to +12.5V, increase V_{IN} to +18V from +15V if this is a problem.

TYPICAL TEMPERATURE VOLTAGE OUTPUT vs TEMPERATURE (REF-02A)

REFERENCE STACK WITH EXCELLENT LINE REGULATION

Two REF-01's and one REF-02 can be stacked to yield 5.000V, 15.000V and 25.000V outputs. An additional advantage of this circuit is near-perfect line regulation of the 5.0V and 15.0V outputs. A 27V to 55V input change produces an output change which is less than the noise voltage of the devices. A load bypass resistor (R_B) provides a path for the supply current (I_{SY}) of the 15.000V regulator.

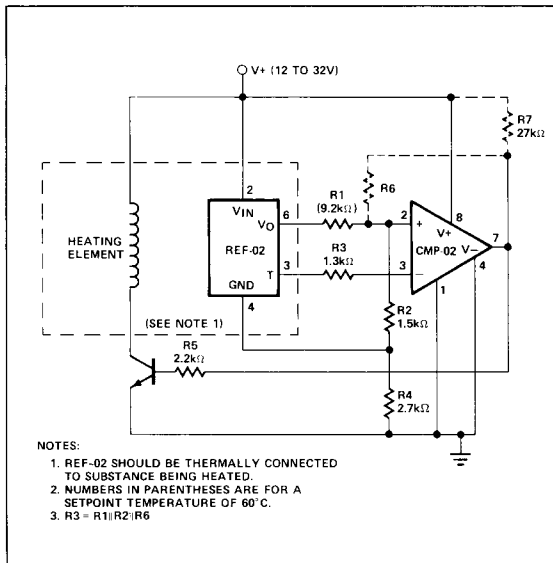
In general, any number of REF-01's and REF-02's can be stacked this way. For example, ten devices will yield ten outputs in 5V or 10V steps. The line voltage can range from 100V to 130V. However, care must be taken to ensure that the total load currents do not exceed the maximum usable current (typically 21mA).

TEMPERATURE CONTROLLER

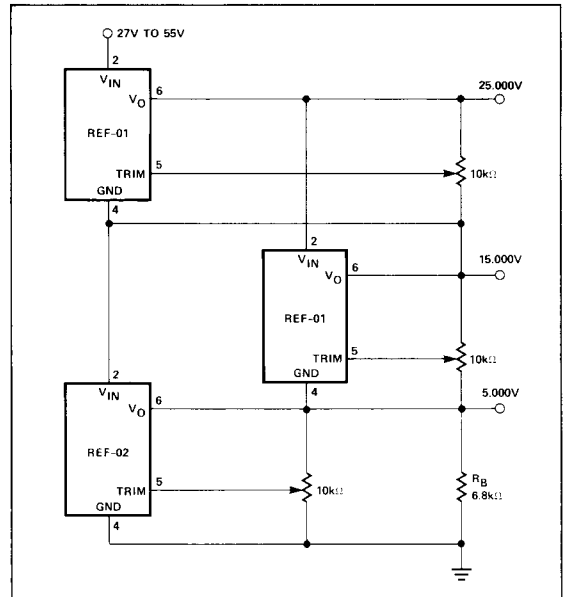
NOTES:

- REF-02 SHOULD BE THERMALLY CONNECTED TO SUBSTANCE BEING HEATED.
- NUMBERS IN PARENTHESES ARE FOR A SETPOINT TEMPERATURE OF 60° C.
- R3 = R1/R2/R6



PRECISION CURRENT SOURCE

A current source with 35V output compliance and excellent output impedance can be obtained using this circuit. REF-02 ② keeps the line voltage and power dissipation constant in device ①; the only important error consideration at room temperature is the negative supply rejection of the op amp. The typical $3\mu\text{V/V}$ PSRR of the OP-02E will create a 20ppm change ($3\mu\text{V/V} \times 35\text{V}/5\text{V}$) in output current over a 35V range. For example, a 5mA current source can be built ($R = 1\text{k}\Omega$) with 350M Ω output impedance.

$$R_O = \frac{35\text{V}}{20 \times 10^{-6} \times 5\text{mA}}$$

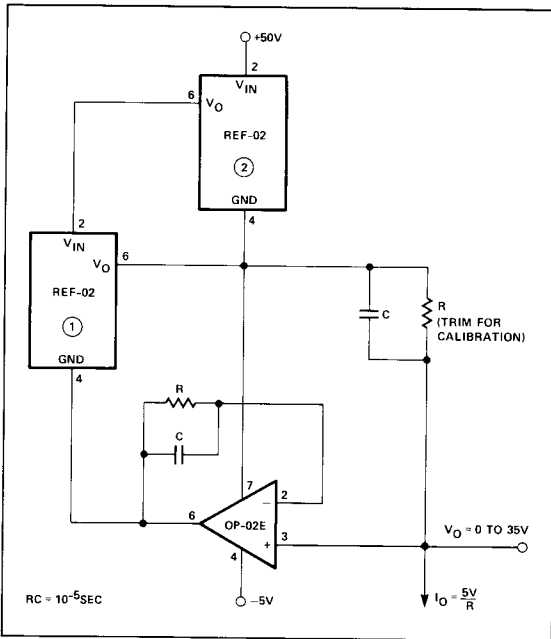

CURRENT SINK

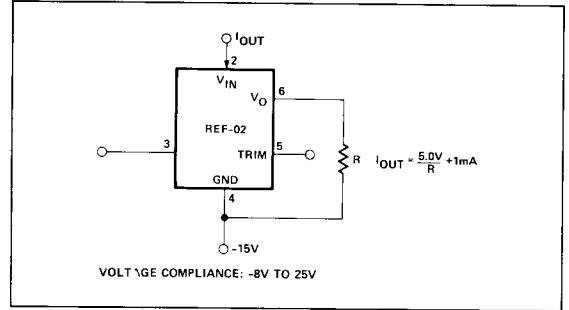

D/A CONVERTER REFERENCE

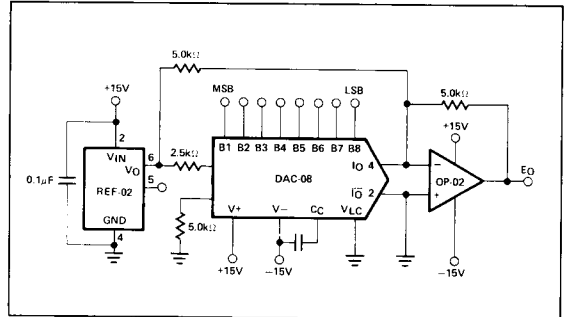

±3V REFERENCE

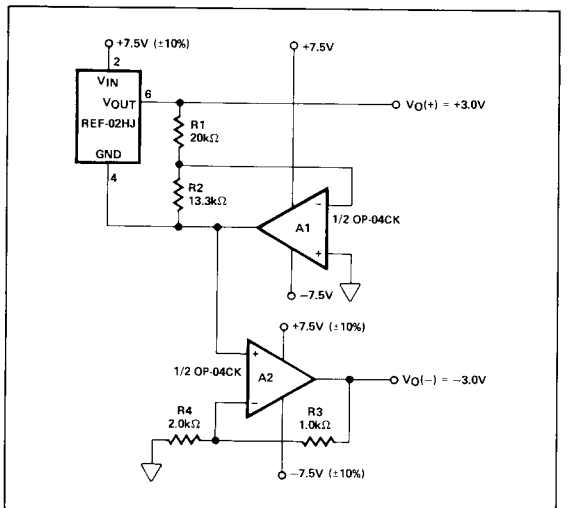

CURRENT SOURCE

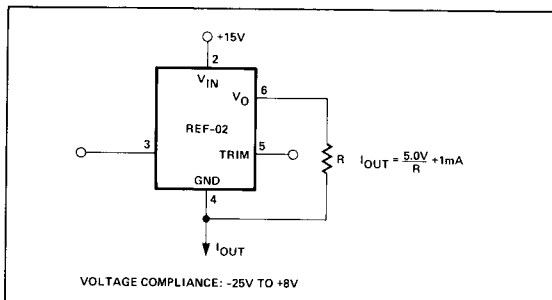

10
VOLTAGE REFERENCES

SUPPLY BYPASSING

For best results, it is recommended that the power supply pin is bypassed with a 0.1 μF disc ceramic capacitor.