



# SMALL SIGNAL DARLINGTON TRANSISTORS (EPOXY)

$I_c = 300\text{mA}$



OPERATING AND STORAGE TEMPERATURE  $-65^\circ$  to  $+150^\circ\text{C}$

TYPE NO.		$I_c$	$V_{CE0}$	$P_D$ (Max) $T_A=25^\circ\text{C}$	$h_{FE}$ @ $I_c$		$V_{CE(S)}$ @ $I_c$			$f_T$ Min	CASE
NPN	PNP	Amps	Volts	Watts	Min - Max	Amps	Volts	Amps	MHZ		
2N5305		0.3	25	0.4	2,000 - 20,000	.002	1.4	0.2	60	 To-92(ECB)	
2N5306		0.3	25	0.4	7,000 - 70,000	.002	1.4	0.2	60		
2N5306A		0.3	25	0.4	7,000 - 70,000	.002	1.4	0.2	60		
2N5307		0.3	40	0.4	2,000 - 20,000	.002	1.4	0.2	60		
2N5308		0.3	40	0.4	7,000 - 70,000	.002	1.4	0.2	60		
2N5308A		0.3	40	0.4	7,000 - 70,000	.002	1.4	0.2	60		
GES5305		0.3	25	0.4	2,000 - 20,000	.002	1.6	0.2	30	 To-92(EBC)	
GES5306		0.3	25	0.4	7,000 - 70,000	.002	1.6	0.2	30		
GES5306A		0.3	25	0.4	7,000 - 70,000	.002	1.6	0.2	30		
GES5307		0.3	40	0.4	2,000 - 20,000	.002	1.6	0.2	30		
GES5308		0.3	40	0.4	7,000 - 70,000	.002	1.6	0.2	30		
GES5308A		0.3	40	0.4	7,000 - 70,000	.002	1.6	0.2	30		
	MPS-A65	0.3	30*	.625	20,000 -	0.1	1.5	0.1	100		
	MPS-A66	0.3	30*	.625	40,000 -	0.1	1.5	0.1	100		
MPS-D04	MPS-D54	0.3	25*	.625	2,000 -	0.1	1.0	0.1	100		

\* $V_{CES}$

$I_c = 500\text{mA}$

OPERATING AND STORAGE TEMPERATURE  $-65^\circ$  to  $+150^\circ\text{C}$

TYPE NO.		$I_c$	$V_{CE0}$	$P_D$ (Max) $T_A=25^\circ\text{C}$	$h_{FE}$ @ $I_c$		$V_{CE(S)}$ @ $I_c$			$f_T$ Min (Typ)	CASE
NPN	PNP	Amps	Volts	Watts	Min - Max	Amps	Volts	Amps	MHZ		
2N6426		0.5	40	.625	30,000-300,000	0.1	1.5	0.5	—	 To-92 (EBC)	
2N6427		0.5	40	.625	20,000-200,000	0.1	1.5	0.5	—		
MPS-A12	MPS-A62	0.5	20	.625	20,000-	0.01	1.0	0.01	—		
MPS-A13	MPS-A63	0.5	30	.500	10,000-	0.1	1.5	0.1	125		
MPS-A14	MPS-A64	0.5	30	.500	20,000-	0.1	1.5	0.1	125		
D40C1		0.5	30	6.25**	10,000-60,000	0.2	1.5	0.5	(75)	 To-202	
D40C2		0.5	30	6.25**	40,000-	0.2	1.5	0.5	(75)		
D40C3		0.5	30	6.25**	90,000-	0.2	1.5	0.5	(75)		
D40C4		0.5	40	6.25**	10,000-60,000	0.2	1.5	0.5	(75)		
D40C5		0.5	40	6.25**	40,000-	0.2	1.5	0.5	(75)		
D40C7		0.5	50	6.25**	10,000-60,000	0.2	1.5	0.5	(75)		
D40C8		0.5	50	6.25**	40,000-	0.2	1.5	0.5	(75)		

\*\* $T_c = 25^\circ\text{C}$

# CASE OUTLINE DRAWINGS

D



**CASE A**      CBR1 Series  
CBR2 Series

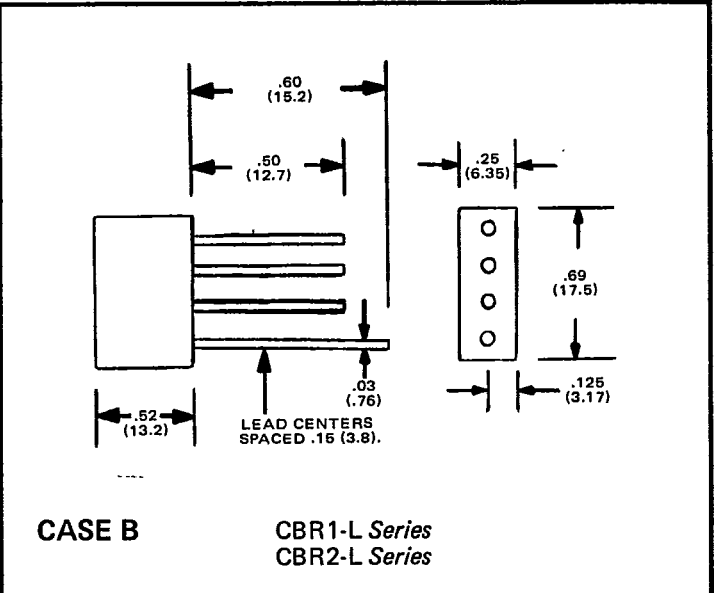

**CASE B**      CBR1-L Series  
CBR2-L Series

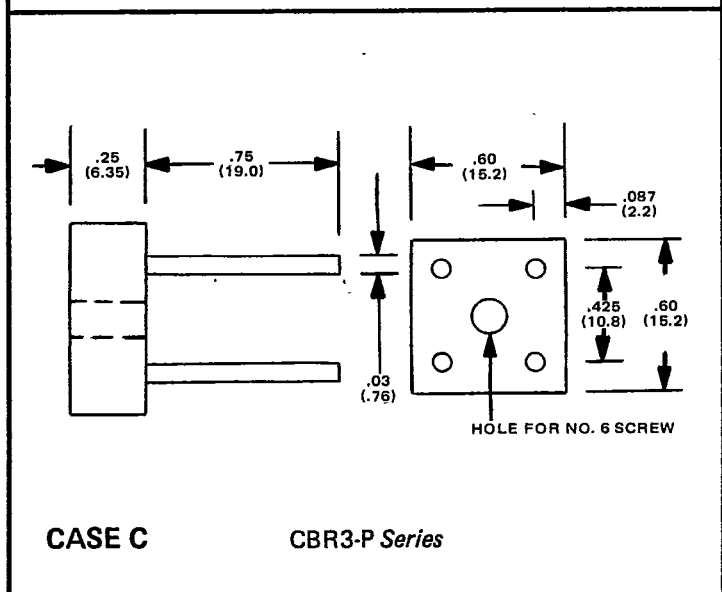

**CASE C**      CBR3-P Series

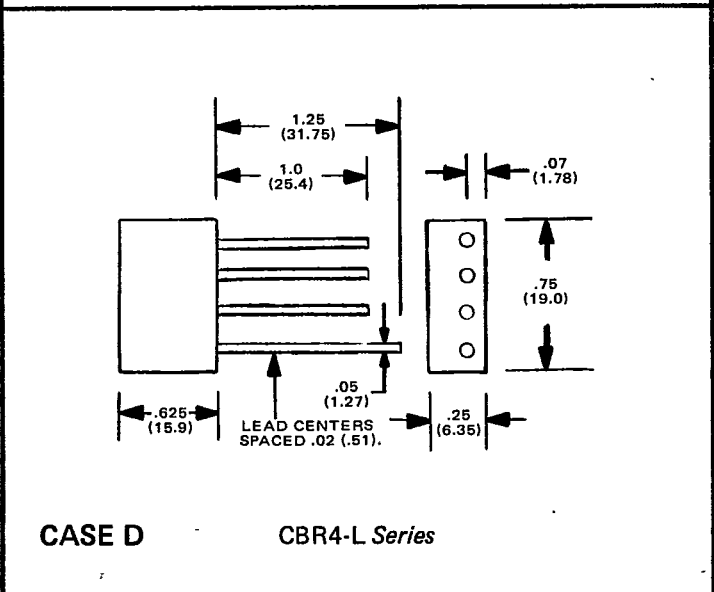

**CASE D**      CBR4-L Series

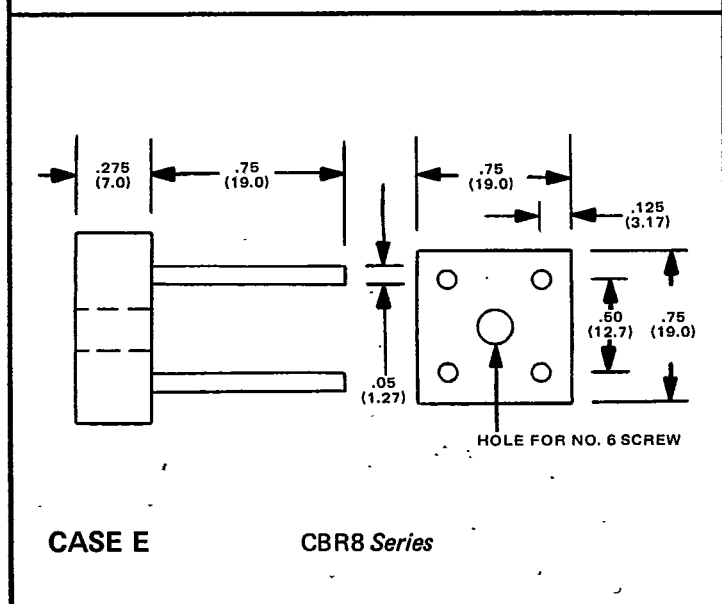

**CASE E**      CBR8 Series

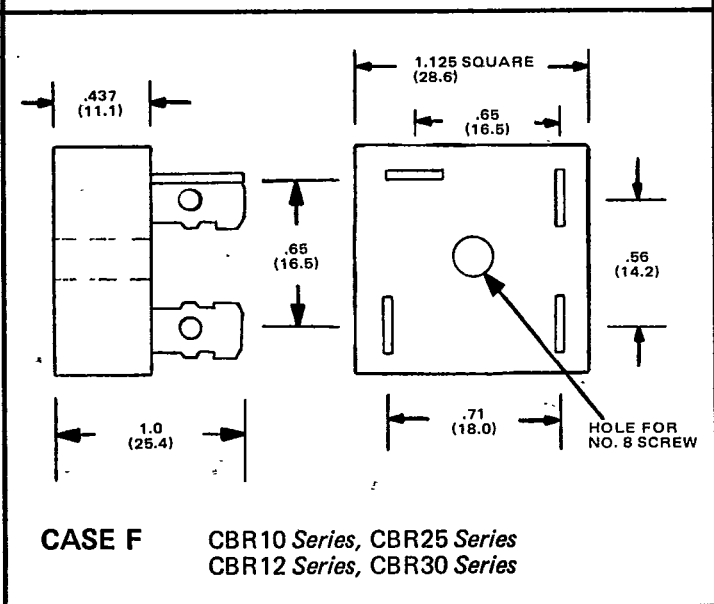

**CASE F**      CBR10 Series, CBR25 Series  
CBR12 Series, CBR30 Series

All Dimensions in Inches (Millimeters)  
Drawings Not To Scale

f

CASE OUTLINE DRAWINGS

T-33-31  
T-33-33

D

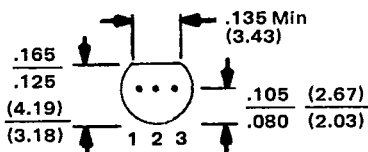
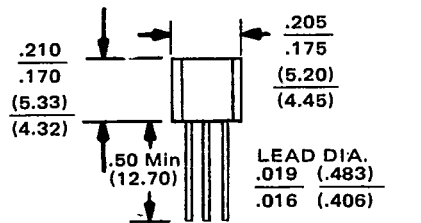

LEAD CENTERS SPACED

.055 (1.40)  
.045 (1.14)

LEAD CODE

1. Emitter
2. Collector
3. Base

To-92(ECB)

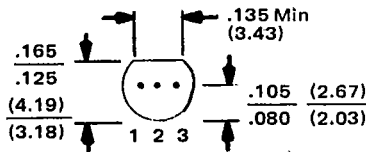
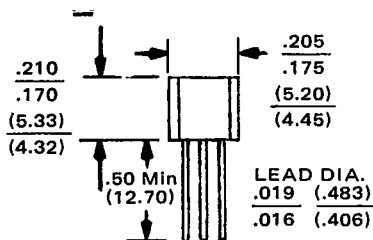

LEAD CENTERS SPACED

.055 (1.40)  
.045 (1.14)

LEAD CODE

1. Emitter
2. Base
3. Collector

To-92(EBC)

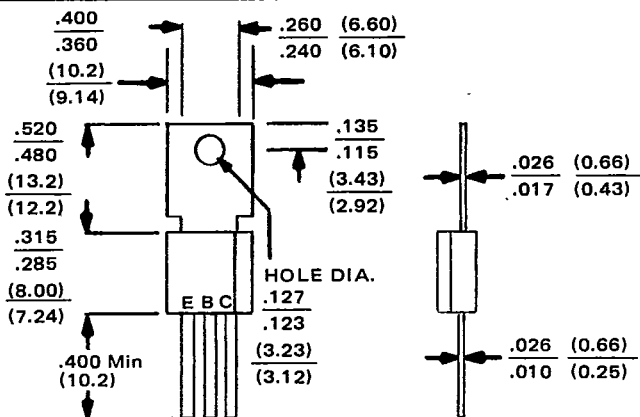

LEAD CENTERS SPACED

.105 (2.67)  
.095 (2.41)

LEAD WIDTH

.055 (1.41)  
.045 (1.14)

To-202

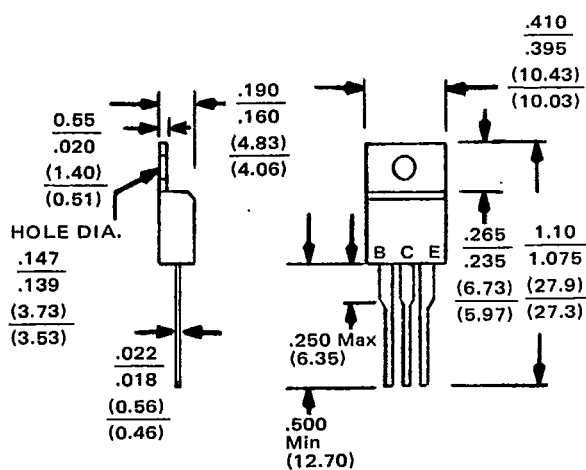

LEAD CENTERS SPACED

.105 (2.67)  
.095 (2.41)

LEAD WIDTH

.032 (0.81)

To-220AB

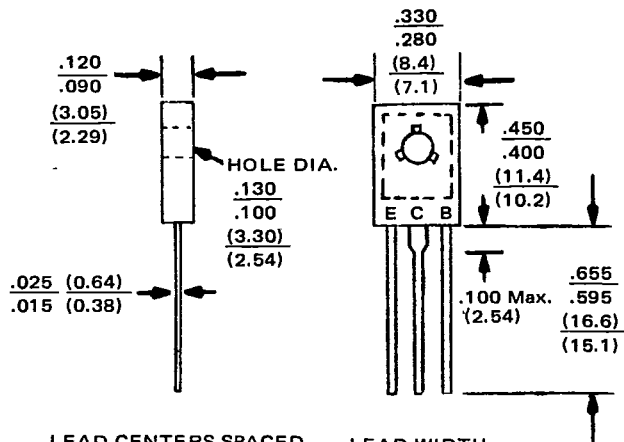

LEAD CENTERS SPACED

.100 (2.54)  
.080 (2.03)

LEAD WIDTH

.035 (0.89)  
.025 (0.64)

To-126

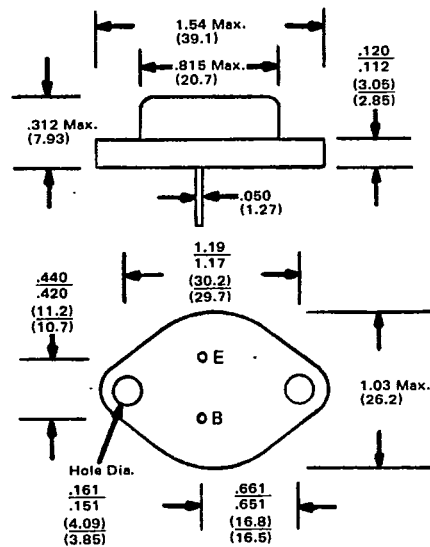

To-3

# MECHANICAL OUTLINE DRAWINGS

TO-5

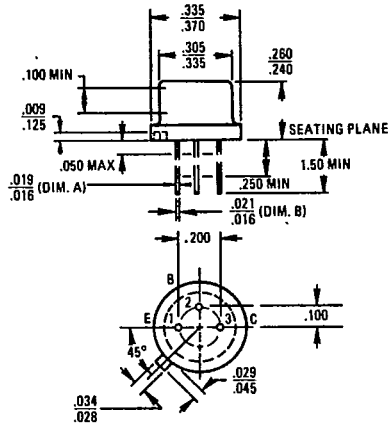

TO-18

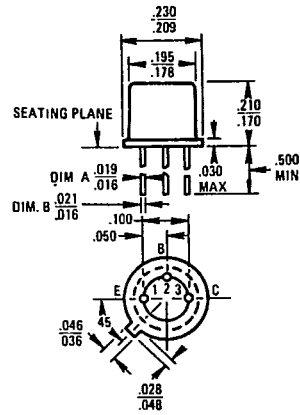

TO-39

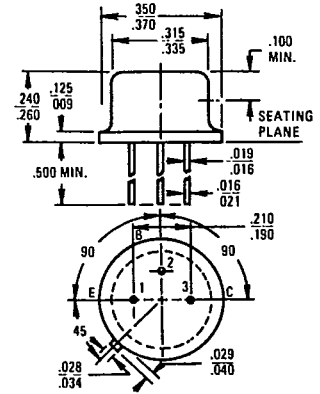

TO-46

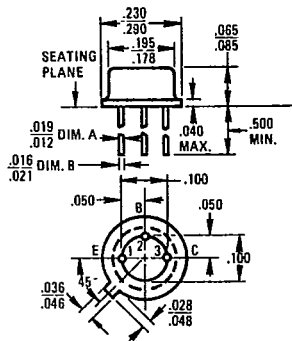

TO-72

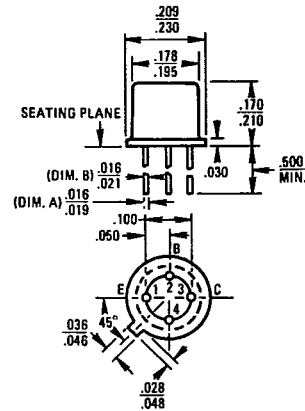

TO-92

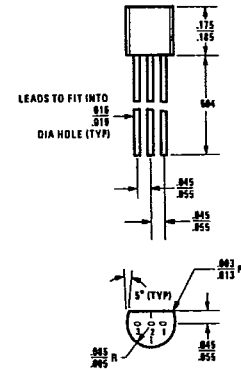

TO-98

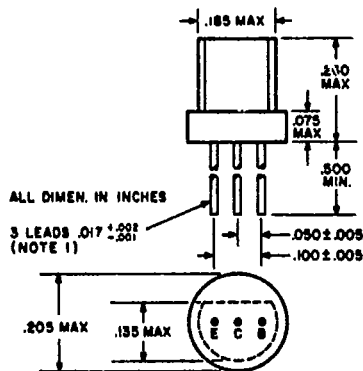

TO-105

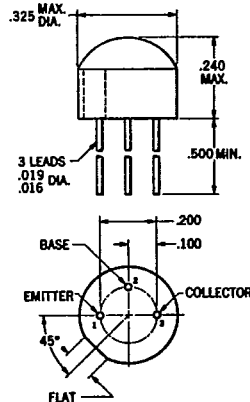

TO-106

