

SF1005CT THRU SF1060CT

List

List..... 1

Package outline..... 2

Features..... 2

Mechanical data..... 2

Maximum ratings2

Rating and characteristic curves..... 3

Pinning information.....4

Marking..... 4

Tube packing.....4

Suggested thermal profiles for soldering processes..... 5

High reliability test capabilities.....6

SF1005CT THRU SF1060CT

10A Super Fast Recovery Rectifiers - 50V-600V

Features

- Dual rectifier construction, positive centetap, offer 5.0A half wave and 10.0A full wave rectification
- High surge current capability.
- Super fast recovery time for switching mode application.
- Low power loss.
- Glass passivated chip junctions.
- Lead-free parts meet environmental standards of MIL-STD-19500/228
- Suffix "-H" indicates Halogen-free parts, ex. SF1005CT-H.

Mechanical data

- Epoxy : UL94-V0 rated flame retardant
- Case : JEDEC TO-220AB molded plastic body over passivated chip
- Lead : Axial leads, solderable per MIL-STD-202, Method 208 guaranteed
- Polarity: As marked
- Mounting Position : Any
- Weight : Approximated 2.10gram

Package outline

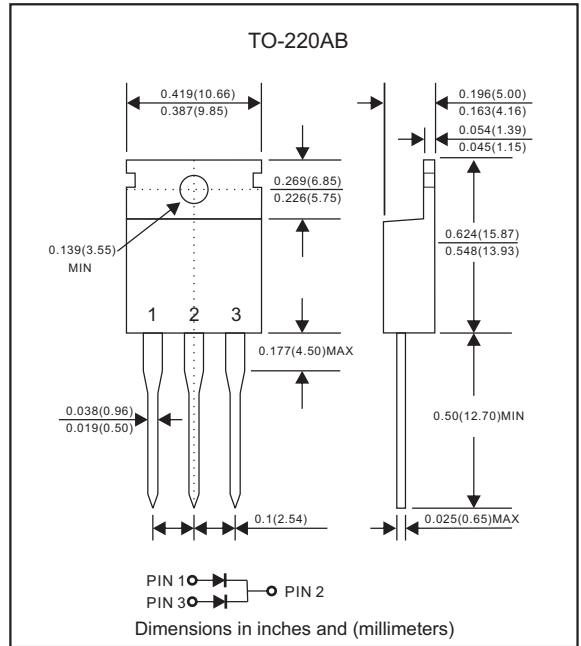

Maximum ratings (AT $T_A=25^{\circ}\text{C}$ unless otherwise noted)

PARAMETER	SYMBOLS	SF1005CT	SF1010CT	SF1020CT	SF1040CT	SF1060CT	UNIT
Maximum repetitive peak reverse voltage	V_{RRM}	50	100	200	400	600	V
Maximum RMS voltage	V_{RMS}	35	70	140	280	420	V
Maximum DC blocking voltage	V_{DC}	50	100	200	400	600	V
Maximum average forward rectified current	I_o	10					A
Peak forward surge current 8.3ms single half sine-wave(JEDEC method)	I_{FSM}	100					A
Operating junction temperature range	T_J	-55 to +150					$^{\circ}\text{C}$
Storage temperature range	T_{STG}	-65 to +175					$^{\circ}\text{C}$

Electrical Characteristics (AT $T_A=25^{\circ}\text{C}$ unless otherwise noted)

PARAMETER	SYMBOLS	SF1005CT	SF1010CT	SF1020CT	SF1040CT	SF1060CT	UNIT
Maximum forward voltage per leg at $I_F=5A$	V_F	0.98			1.30	1.70	V
Maximum DC reverse current at $T_J=25^{\circ}\text{C}$ at rated DC blocking voltage per leg at $T_J=125^{\circ}\text{C}$	I_R	5.0			250		μA μA
Maximum reverse recovery time per leg (Note 1)	t_{rr}	35					ns

Thermal Characteristics

PARAMETER	SYMBOLS	SF1005CT	SF1010CT	SF1020CT	SF1040CT	SF1060CT	UNIT
Typical thermal resistance junction to case per leg	$R_{\theta JC}$	2.5					$^{\circ}\text{C}/\text{W}$

Note 1: Reverse recovery time test condition, $I_F=0.5A$, $I_R=1.0A$, $I_{RR}=0.25A$

Rating and characteristic curves (SF1005CT THRU SF1060CT)

FIG.1-TYPICAL FORWARD CURRENT DERATING CURVE

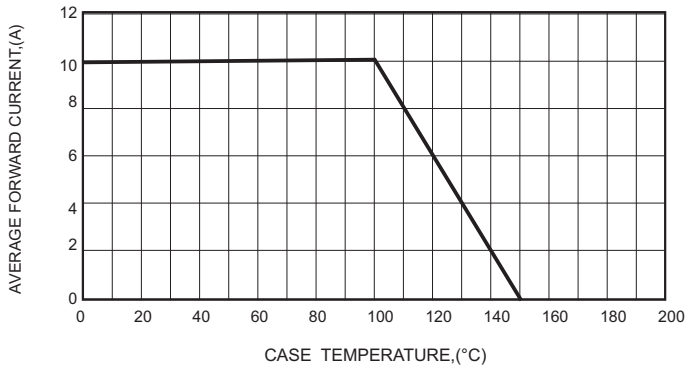

FIG.3-MAXIMUM NON-REPETITIVE FORWARD SURGE CURRENT

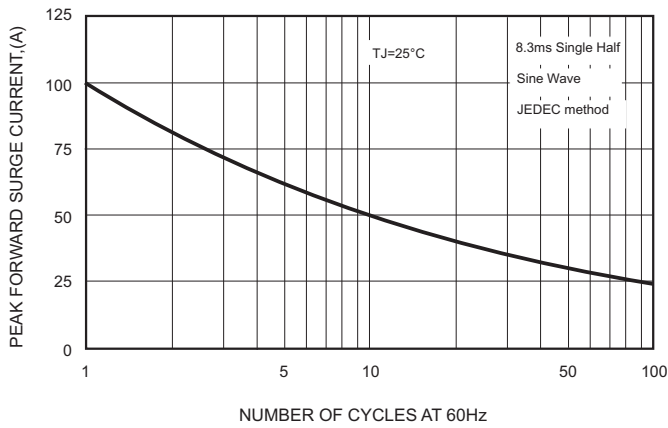

FIG.2-TYPICAL FORWARD CHARACTERISTICS

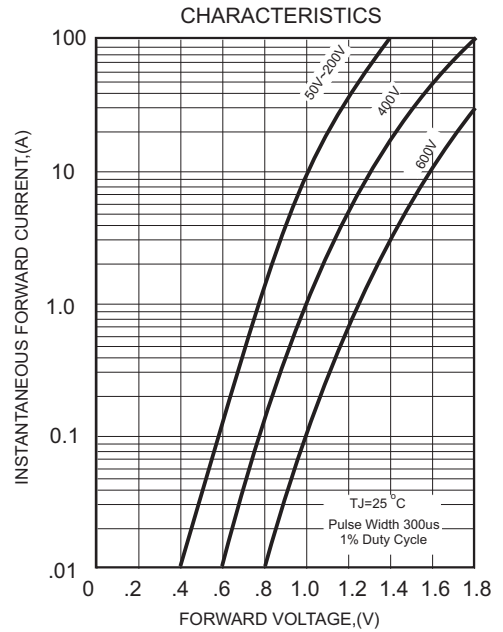

FIG.4 - TYPICAL REVERSE CHARACTERISTICS

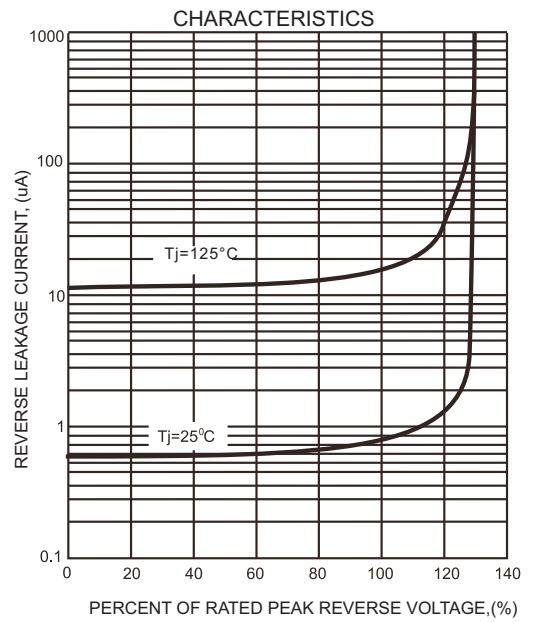
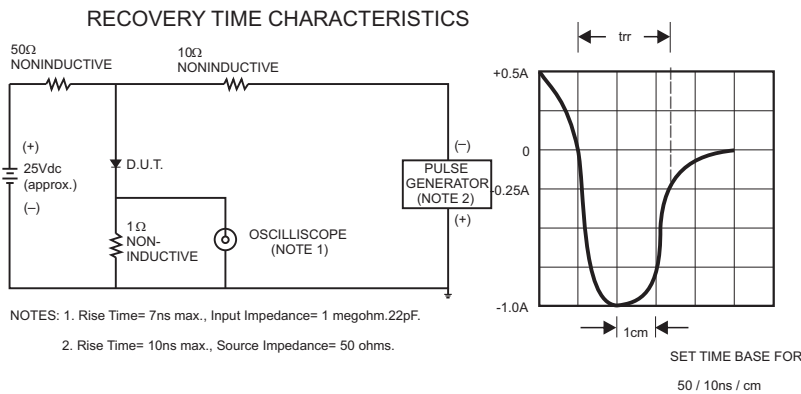

FIG.5- TEST CIRCUIT DIAGRAM AND REVERSE RECOVERY TIME CHARACTERISTICS



NOTES: 1. Rise Time= 7ns max., Input Impedance= 1 megohm, 22pF.
2. Rise Time= 10ns max., Source Impedance= 50 ohms.

SF1005CT THRU SF1060CT

Pinning information

Pin	Simplified outline	Symbol
Pin1 anode Pin2 cathode Pin3 anode		

Marking

Type number	Marking code
SF1005CT	SF1005CT
SF1010CT	SF1010CT
SF1020CT	SF1020CT
SF1040CT	SF1040CT
SF1060CT	SF1060CT

Tube packing

PACKAGE	TUBE (pcs)	TUBE SIZE (m/m)	BOX (pcs)	INNER BOX (m/m)	CARTON SIZE (m/m)	CARTON (pcs)	APPROX. GROSS WEIGHT (kg)
TO-220AB	50	525*32*7.5	1000	555*150*40	580*230*175	5,000	15.0

SF1005CT THRU SF1060CT

Suggested thermal profiles for soldering processes

1. Lead free temperature profile wave-soldering

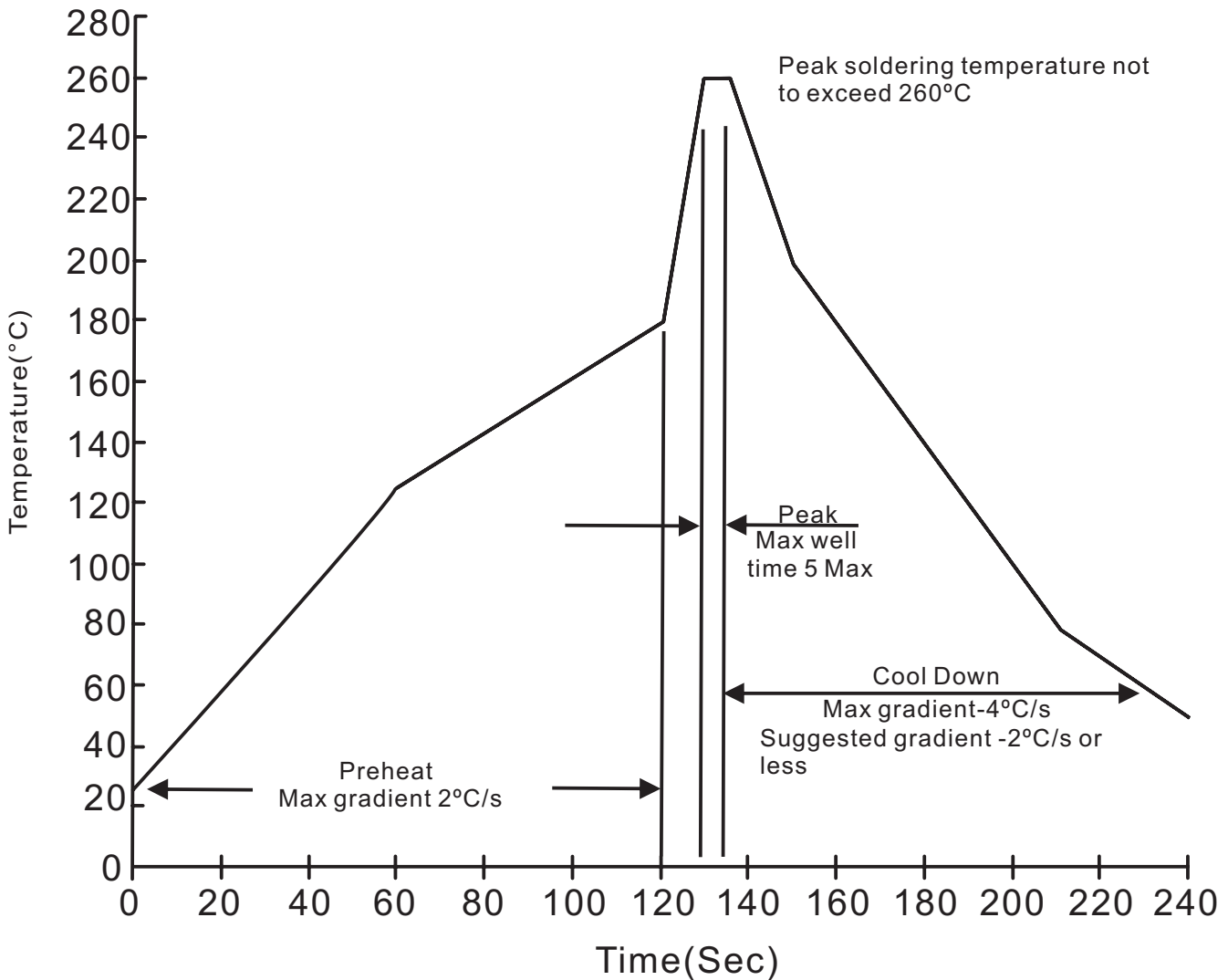

SF1005CT THRU SF1060CT

High reliability test capabilities

Item Test	Conditions	Reference
1. Solder Resistance	at 260±5°C for 10±2sec. immerse body into solder 1/16"±1/32"	MIL-STD-750D METHOD-2031
2. Solderability	at 245±5°C for 5 sec.	MIL-STD-202F METHOD-208
3. High Temperature Reverse Bias	$V_R=80\%$ rate at $T_J=150^\circ\text{C}$ for 168 hrs.	MIL-STD-750D METHOD-1038
4. Forward Operation Life	Rated average rectifier current at $T_A=25^\circ\text{C}$ for 500hrs.	MIL-STD-750D METHOD-1027
5. Intermittent Operation Life	$T_A = 25^\circ\text{C}$, $I_F = I_O$ On state: power on for 5 min. off state: power off for 5 min. on and off for 500 cycles.	MIL-STD-750D METHOD-1036
6. Pressure Cooker	15P _{SIG} at $T_A=121^\circ\text{C}$ for 4 hrs.	JESD22-A102
7. Temperature Cycling	-55°C to +125°C dwelled for 30 min. and transferred for 5min. total 10 cycles.	MIL-STD-750D METHOD-1051
8. Forward Surge	8.3ms single half sine-wave , one surge.	MIL-STD-750D METHOD-4066-2
9. Humidity	at $T_A=85^\circ\text{C}$, RH=85% for 1000hrs.	MIL-STD-750D METHOD-1021
10. High Temperature Storage Life	at 175°C for 1000 hrs.	MIL-STD-750D METHOD-1031