

REVISION T

UNLESS OTHERWISE NOTED
 DIMENSIONS ARE IN INCHES TOLERANCES ARE:
 ONE PLACE DECIMALS ± .1[2.54] THREE PLACE DECIMALS ± .005[.13] ANGLES ± 2°
 TWO PLACE DECIMALS ± .01[.25] FOUR PLACE DECIMALS ± .0020[.051]

TITLE: .050 [1.27] ϕ
 SOCKET MICRO STRIP

DWG NO: SMS-1XX-XX-X-S
 SHEET 1 OF 1

SMS-1XX-XX-X-S

BODY LENGTH SPECIFICATION
 -01 THRU -50 POSITIONS

BODY SPECIFICATION
 -S: SINGLE ROW (USE SMS-50-S)

CONTACT SPECIFICATION
 (SEE TABLE 1)
 USE SPECIFIED LEAD STYLE TO IDENTIFY CONTACT

PLATING SPECIFICATION
 -G: GOLD (SPECIFY G IN CONTACT SUFFIX 'X')
 -T: TIN (SPECIFY T IN CONTACT SUFFIX 'X')
 -S: SELECTIVE (SPECIFY S IN CONTACT SUFFIX 'X')
 -F: FLASH SELECTIVE GOLD (SPECIFY F IN CONTACT SUFFIX 'X')
 (AVAILABLE IN -01 LEAD STYLE ONLY)
 -H: HEAVY GOLD (SPECIFY H IN CONTACT SUFFIX 'X')

TABLE 1

LEAD STYLE	CONTACT	'B'	PKG TUBE (SEE NOTE 5)	PLUG
01	C-16-1-X	.100 [2.54]	PT-1-24-01-53	TP-24-02
02	C-16-2-X	.190 [4.83]		

- NOTES:
- 1.) MAX. BOWING AFTER ASSEMBLY .006 [.15] INCH/INCH
 - 2.) MAX. FLASH .005 [.13]
 - 3.) ϕ REPRESENTS A CRITICAL DIMENSION FOR STATISTICAL PROCESS CONTROL USE.
 - 4.) PARTS CUT TO POSITION SHOULD BE SYMMETRICAL ABOUT C. END WALLS OF CUT BODIES SHALL BE .012 [.30] MIN. WHEN MEASURED AT CONTACT TAIL.
 - 5.) PACKAGE ONLY POSITIONS 10 THROUGH 50 IN TUBES. BOX PACKAGE POSITIONS 01 THROUGH 09.
 - 6.) CONTACT PUSHOUT FORCE: 1.5 LBS. MIN

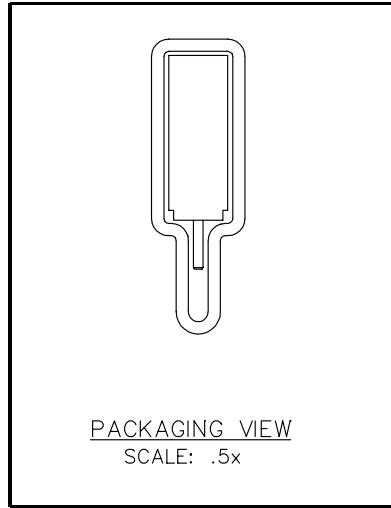
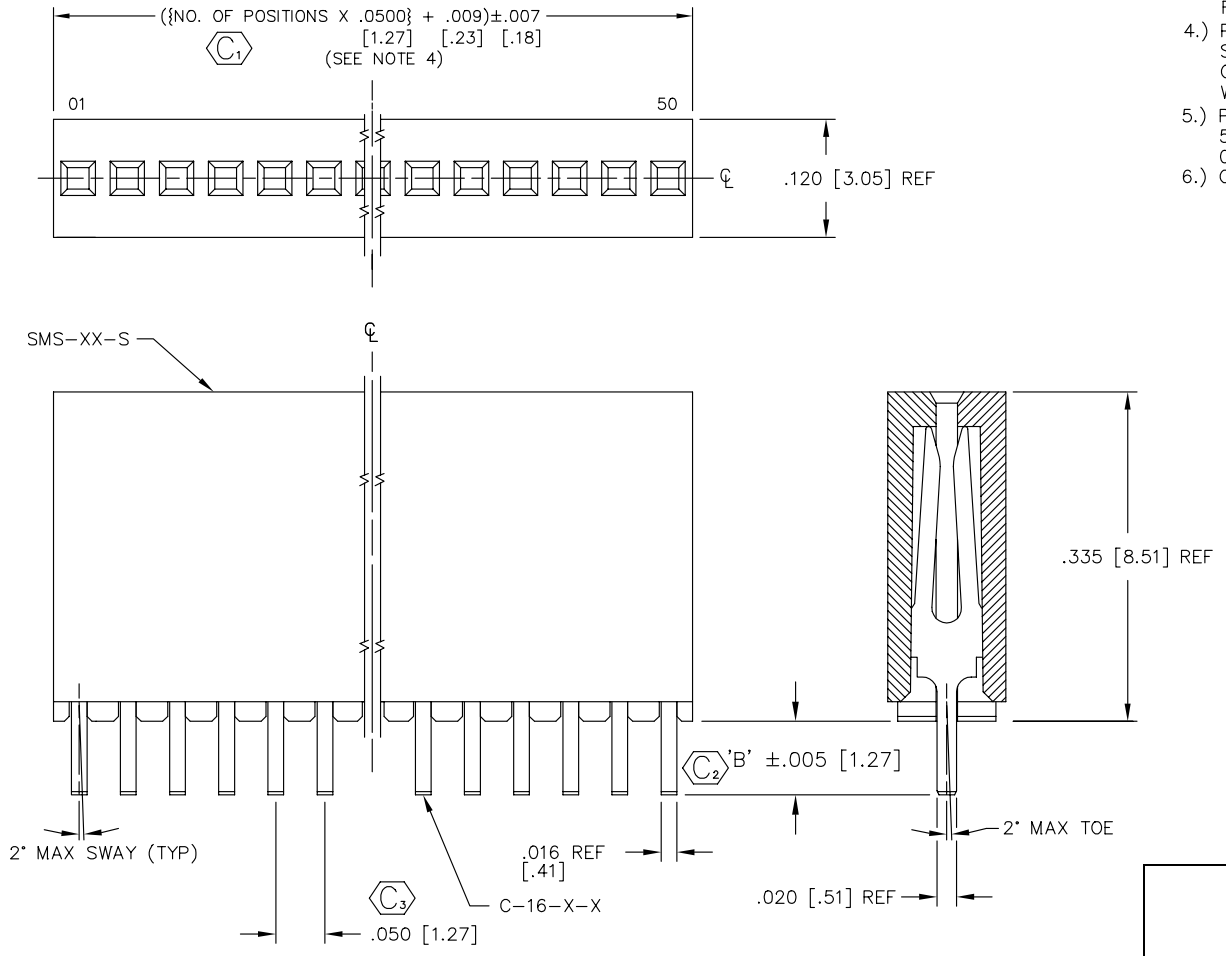

PROPRIETARY NOTE
 THIS DOCUMENT CONTAINS INFORMATION CONFIDENTIAL AND PROPRIETARY TO SAMTEC INC. AND SHALL NOT BE REPRODUCED OR TRANSFERRED TO OTHER DOCUMENTS OR DISCLOSED TO OTHERS OR USED FOR ANY PURPOSE OTHER THAN THAT FOR WHICH IT WAS OBTAINED WITHOUT THE EXPRESSED WRITTEN CONSENT OF SAMTEC INC.

EXISPROD\ASSEMBLY\050 SMS-SASM

samtec

520 PARK EAST BLVD. NEW ALBANY, INDIANA 47150
 PHONE (812) 944-6733 P.O. BOX 1147
 CODE 55322

MADE BY: L. WILLIAMS 7-20-84 SMS-1XX-XX-X-S
 SHEET 1 OF 1