

General Description

The MA3001J is the highest performance trench P-ch MOSFETs with extreme high cell density, which provide excellent RDSON and gate charge for most of the synchronous buck converter applications.

The MA3001J meet the RoHS and Green Product requirement, with full function reliability approved.

Features

- Advanced high cell density Trench technology
- Super Low Gate Charge
- Excellent CdV/dt effect decline
- Green Device Available

Product Summary



BVDSS	RDSON	ID
-30V	52mΩ	-4.5A

Applications

- High Frequency Point-of-Load Synchronous Buck Converter
- Networking DC-DC Power System
- Load Switch

SOT89 Pin Configuration

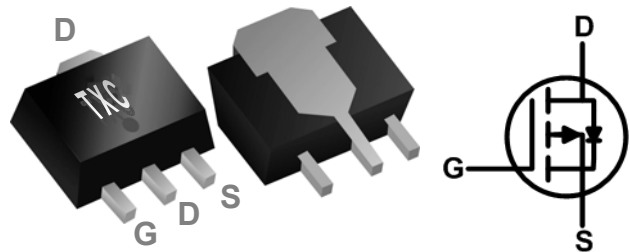

Absolute Maximum Ratings

Symbol	Parameter	Rating	Units
V_{DS}	Drain-Source Voltage	-30	V
V_{GS}	Gate-Source Voltage	± 20	V
$I_D@T_A=25$	Continuous Drain Current, $V_{GS} @ -10V^1$	-4.5	A
$I_D@T_A=70$	Continuous Drain Current, $V_{GS} @ -10V^1$	-3.5	A
I_{DM}	Pulsed Drain Current ²	-9	A
$P_D@T_A=25$	Total Power Dissipation ³	1.5	W
T_{STG}	Storage Temperature Range	-55 to 150	
T_J	Operating Junction Temperature Range	-55 to 150	

Thermal Data

Symbol	Parameter	Typ.	Max.	Unit
$R_{\theta JA}$	Thermal Resistance Junction-Ambient ¹	---	85	/W
$R_{\theta JC}$	Thermal Resistance Junction-Case ¹	---	30	/W

Electrical Characteristics ($T_J=25$, unless otherwise noted)

Symbol	Parameter	Conditions	Min.	Typ.	Max.	Unit
BV_{DSS}	Drain-Source Breakdown Voltage	$V_{GS}=0V, I_D=-250\mu A$	-30	---	---	V
BV_{DSS}/T_J	BV_{DSS} Temperature Coefficient	Reference to 25 , $I_D=-1mA$	---	-0.023	---	V/
$R_{DS(ON)}$	Static Drain-Source On-Resistance ²	$V_{GS}=-10V, I_D=-4A$	---	42	52	m Ω
		$V_{GS}=-4.5V, I_D=-2A$	---	75	90	
$V_{GS(th)}$	Gate Threshold Voltage	$V_{GS}=V_{DS}, I_D=-250\mu A$	-1.0	-1.6	-2.5	V
$V_{GS(th)}$	$V_{GS(th)}$ Temperature Coefficient		---	4	---	mV/
I_{DSS}	Drain-Source Leakage Current	$V_{DS}=-24V, V_{GS}=0V, T_J=25$	---	---	1	μA
		$V_{DS}=-24V, V_{GS}=0V, T_J=55$	---	---	5	
I_{GSS}	Gate-Source Leakage Current	$V_{GS}=\pm 20V, V_{DS}=0V$	---	---	± 100	nA
gfs	Forward Transconductance	$V_{DS}=-10V, I_D=-4A$	---	6	---	S
Q_g	Total Gate Charge (-4.5V)	$V_{DS}=-20V, V_{GS}=-4.5V, I_D=-4A$	---	6.4	---	nC
Q_{gs}	Gate-Source Charge		---	2.2	---	
Q_{gd}	Gate-Drain Charge		---	2.3	---	
$T_{d(on)}$	Turn-On Delay Time	$V_{DD}=-12V, V_{GS}=-10V, R_G=3.3\Omega, I_D=-4A$	---	9	---	ns
T_r	Rise Time		---	16.6	---	
$T_{d(off)}$	Turn-Off Delay Time		---	21	---	
T_f	Fall Time		---	21.6	---	
C_{iss}	Input Capacitance	$V_{DS}=-15V, V_{GS}=0V, f=1MHz$	---	655	---	pF
C_{oss}	Output Capacitance		---	100	---	
C_{rss}	Reverse Transfer Capacitance		---	74	---	

Diode Characteristics

Symbol	Parameter	Conditions	Min.	Typ.	Max.	Unit
I_S	Continuous Source Current ^{1,4}	$V_G=V_D=0V, \text{ Force Current}$	---	---	-4.5	A
I_{SM}	Pulsed Source Current ^{2,4}		---	---	-9	A
V_{SD}	Diode Forward Voltage ²	$V_{GS}=0V, I_S=-1A, T_J=25$	---	---	-1	V

Note :

- 1.The data tested by surface mounted on a 1 inch²FR-4 board with 20Z copper.
- 2.The data tested by pulsed , pulse width $\leq 300\mu s$, duty cycle $\leq 2\%$
- 3.The power dissipation is limited by 150 junction temperature
- 4.The data is theoretically the same as I_D and I_{DM} , in real applications , should be limited by total power dissipation.

Typical Characteristics

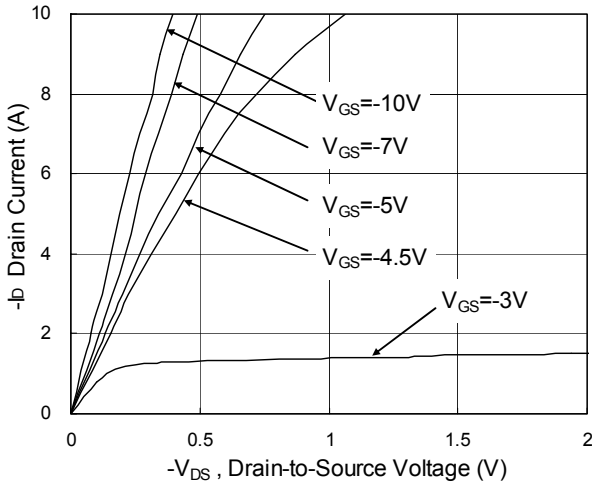

Fig.1 Typical Output Characteristics

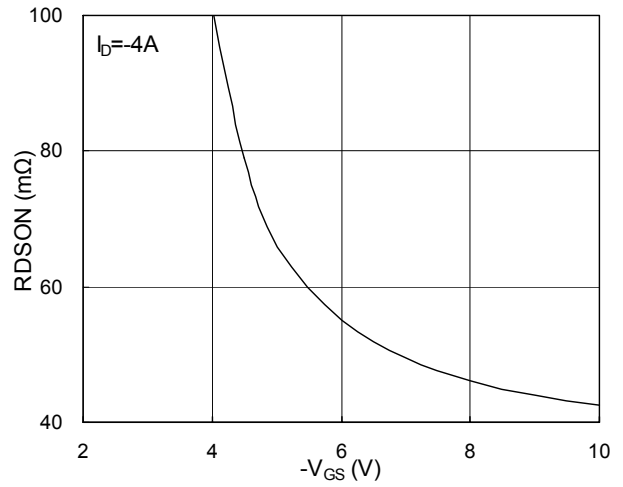

Fig.2 On-Resistance vs. Gate-Source

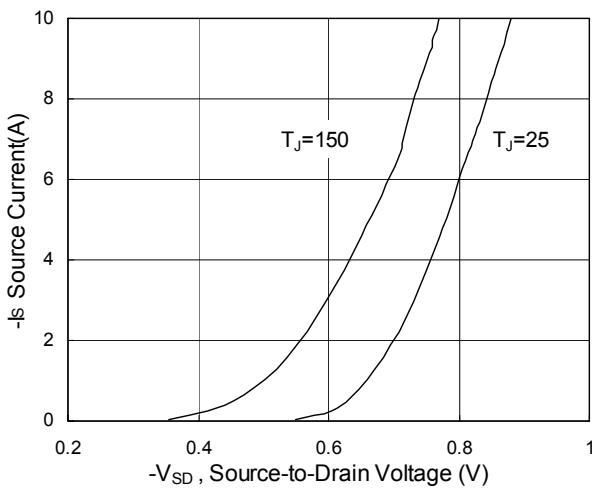

Fig.3 Forward Characteristics of Reverse

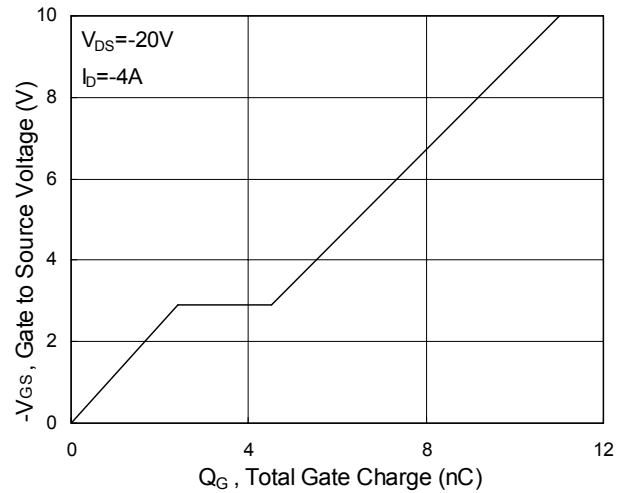

Fig.4 Gate-Charge Characteristics

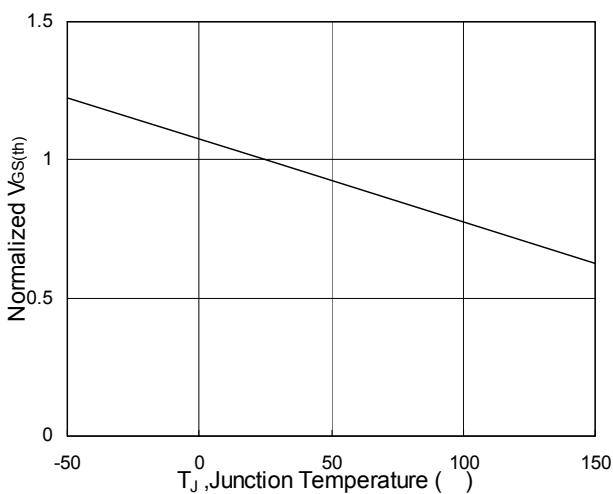

Fig.5 Normalized $V_{GS(th)}$ vs. T_J

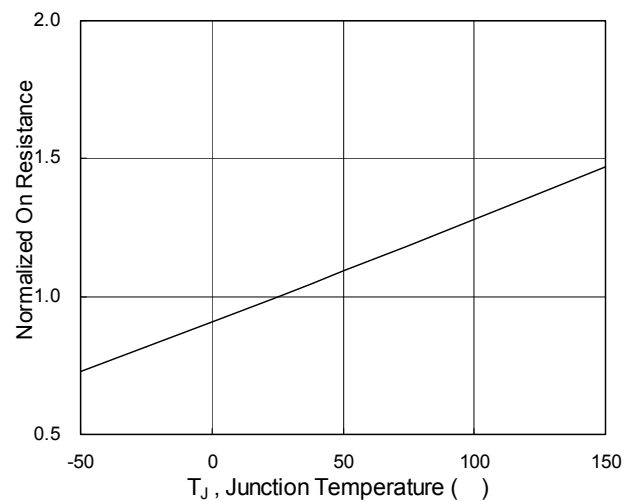

Fig.6 Normalized $R_{DS(on)}$ vs. T_J

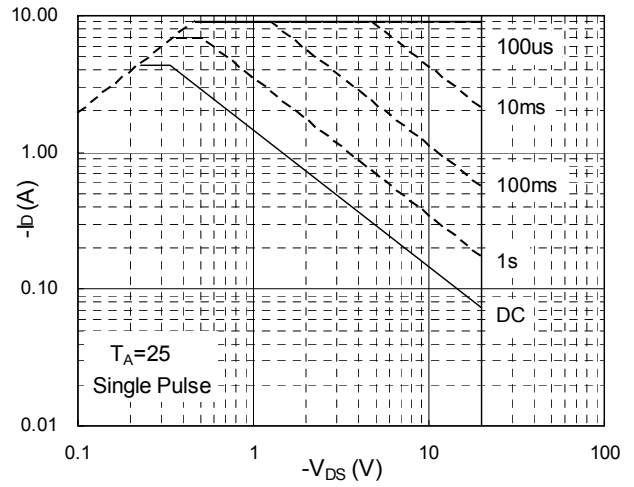
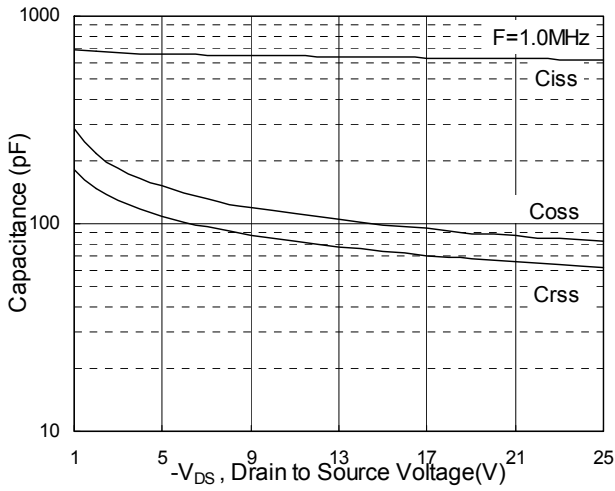

Fig.7 Capacitance

Fig.8 Safe Operating Area

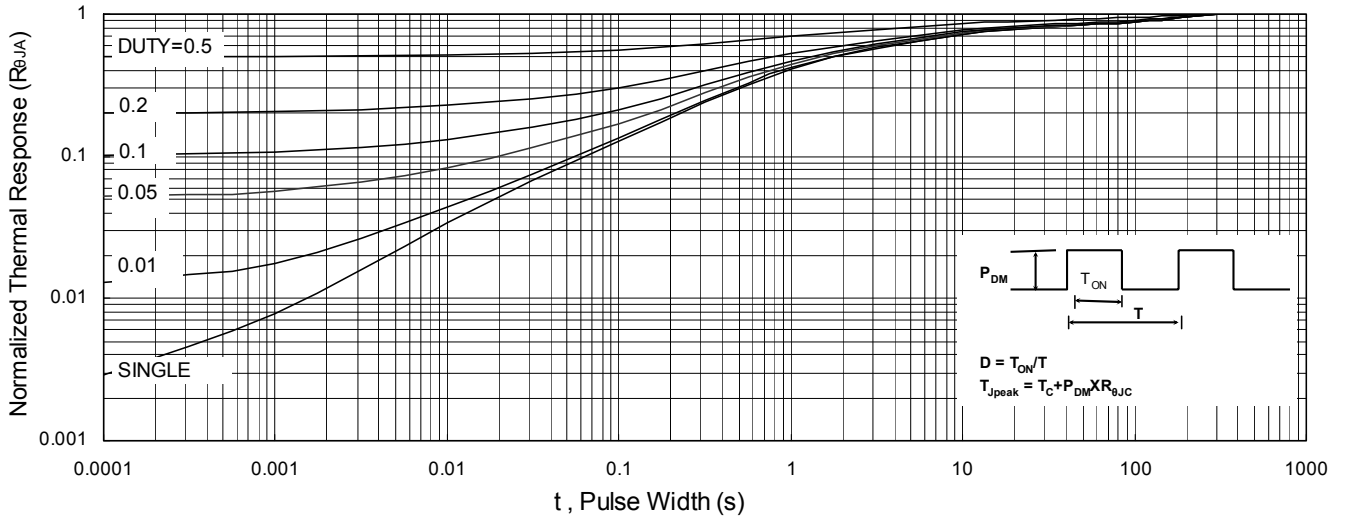

Fig.9 Normalized Maximum Transient Thermal Impedance

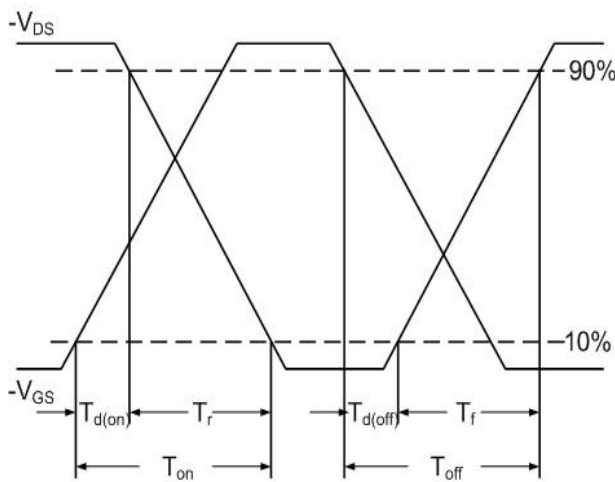

Fig.10 Switching Time Waveform

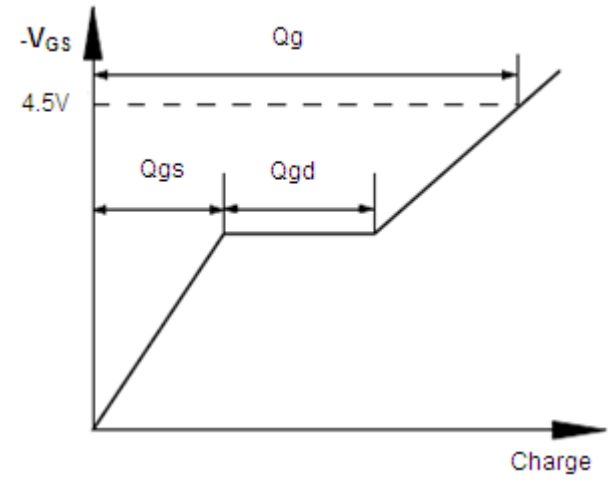
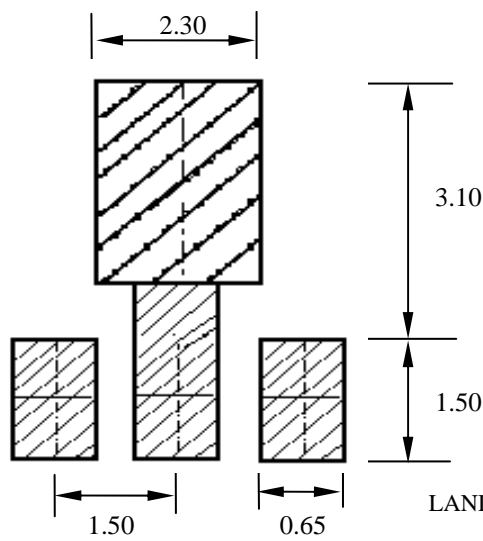
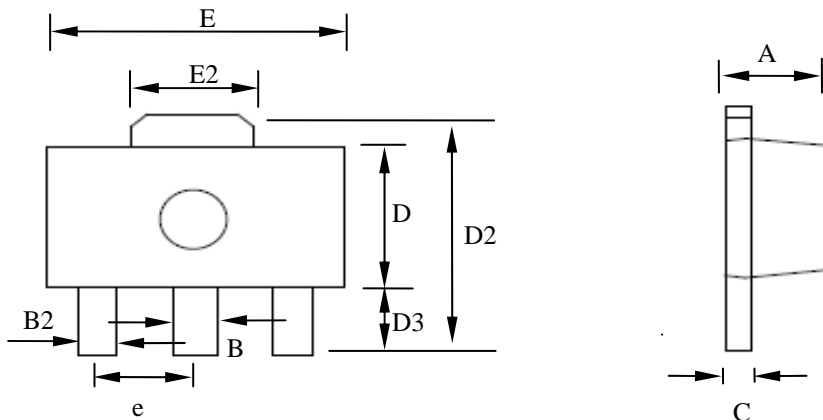

Fig.11 Gate Charge Waveform

SOT-89 Outline

P-Ch 30V Fast Switching MOSFETs



UNIT:mm

LAND PATTERN RECOMMENDATION

MARKING

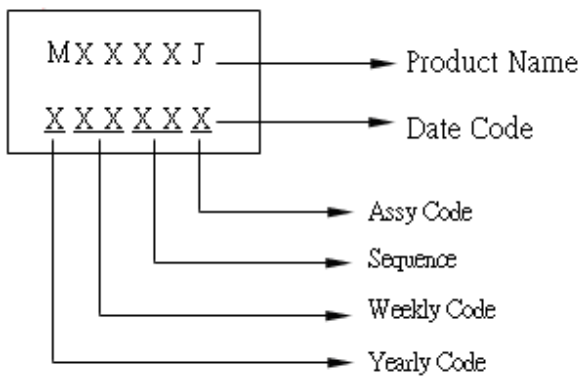

SYMBOLS	MILLIMETERS			INCHES		
	MIN	NOM	MAX	MIN	NOM	MAX
A	1.40	--	1.60	0.055	--	0.063
B	0.40	--	0.55	0.016	--	0.022
B2	0.35	--	0.48	0.014	--	0.019
C	0.35	--	0.43	0.014	--	0.017
D	2.40	--	2.60	0.094	--	0.102
D2	3.80	--	4.25	0.150	--	0.167
D3	0.80	--	1.20	0.031	--	0.047
E	4.40	--	4.60	0.173	--	0.181
E2	1.40	--	1.80	0.055	--	0.071
e	1.30	--	1.70	0.051	--	0.067

Note:

1. PACKAGE BODY SIZES EXCLUDE MOLD FLASH AND GATE BURRS.
2. CONTROLLING DIMENSION IS MILLIMETER CONVERTED INCH DIMENSIONS ARE NOT NECESSARILY EXACTLY.

Tape & Reel 繞捲及裝箱方式(SOT-89)

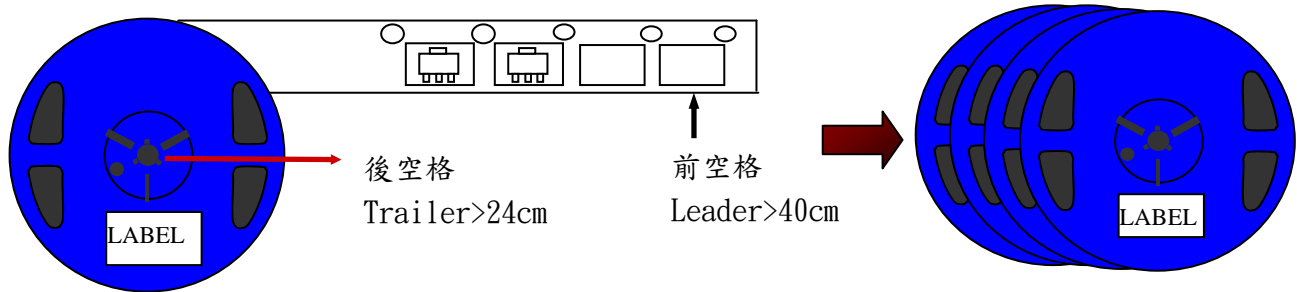

產品正印及方向 - (正印為正時，Tape 圓孔在上方)

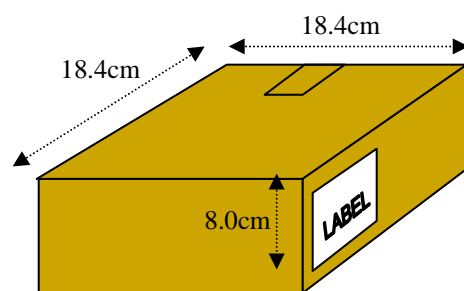
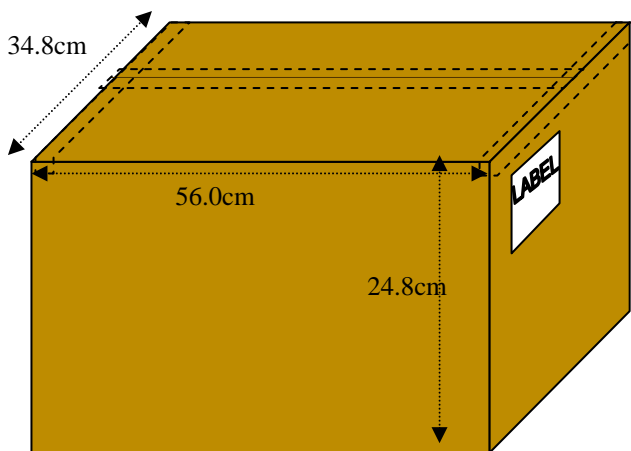
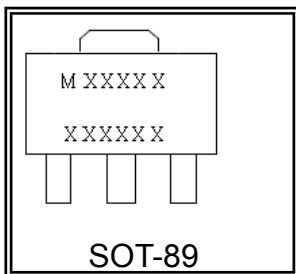

封裝形態 PKG TYPE	一般包裝		
	一卷數量 Immediate Quantity	中箱數量 Intermediate Quantity	外箱裝置/數量 Carton Quantity
SOT-89	1000pcs	4000pcs	48K
	Reel (7")	Box(4 reels)	Carton(12 Box)