

THIS DRAWING IS UNPUBLISHED. RELEASED FOR PUBLICATION, 19
 © COPYRIGHT 19 BY AMP INCORPORATED, HARRISBURG, PA. ALL INTERNATIONAL RIGHTS RESERVED. AMP PRODUCTS MAY BE COVERED BY U.S. AND FOREIGN PATENTS AND/OR PATENTS PENDING.

REVISIONS						
R	F	ZONE	LTR	DESCRIPTION	DATE	APPROVED
		0		REF. 87-5189-001-1,-2 m.s.	3-88	
		01		REL. 87-5184-001-4 m.s.	9-88	DRS
		02		ADD - 4 THRU - 8 db	11-88	DRS
		03		ADD - 9 db	3-89	DRS
		A		REV PER 0010-0826-25 RAC	9-93	JM
		B		REV PER 0010-1558-93 IT	12-93	JM

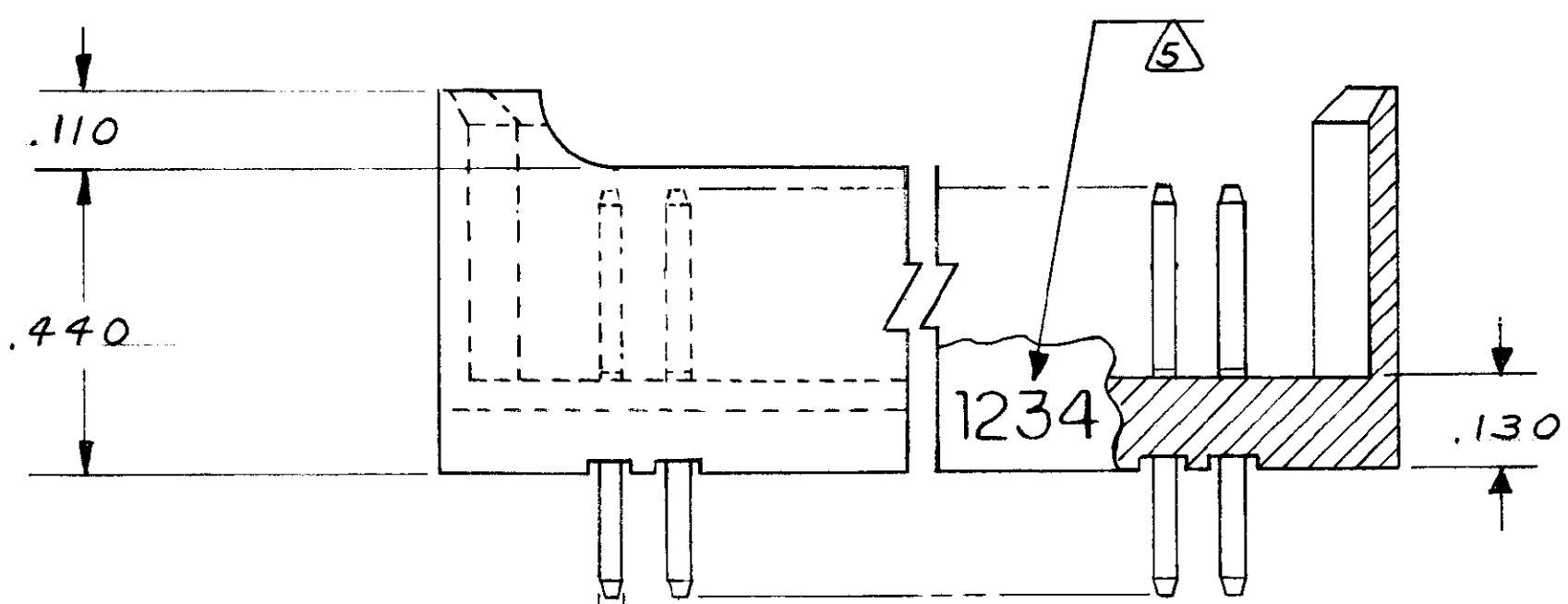
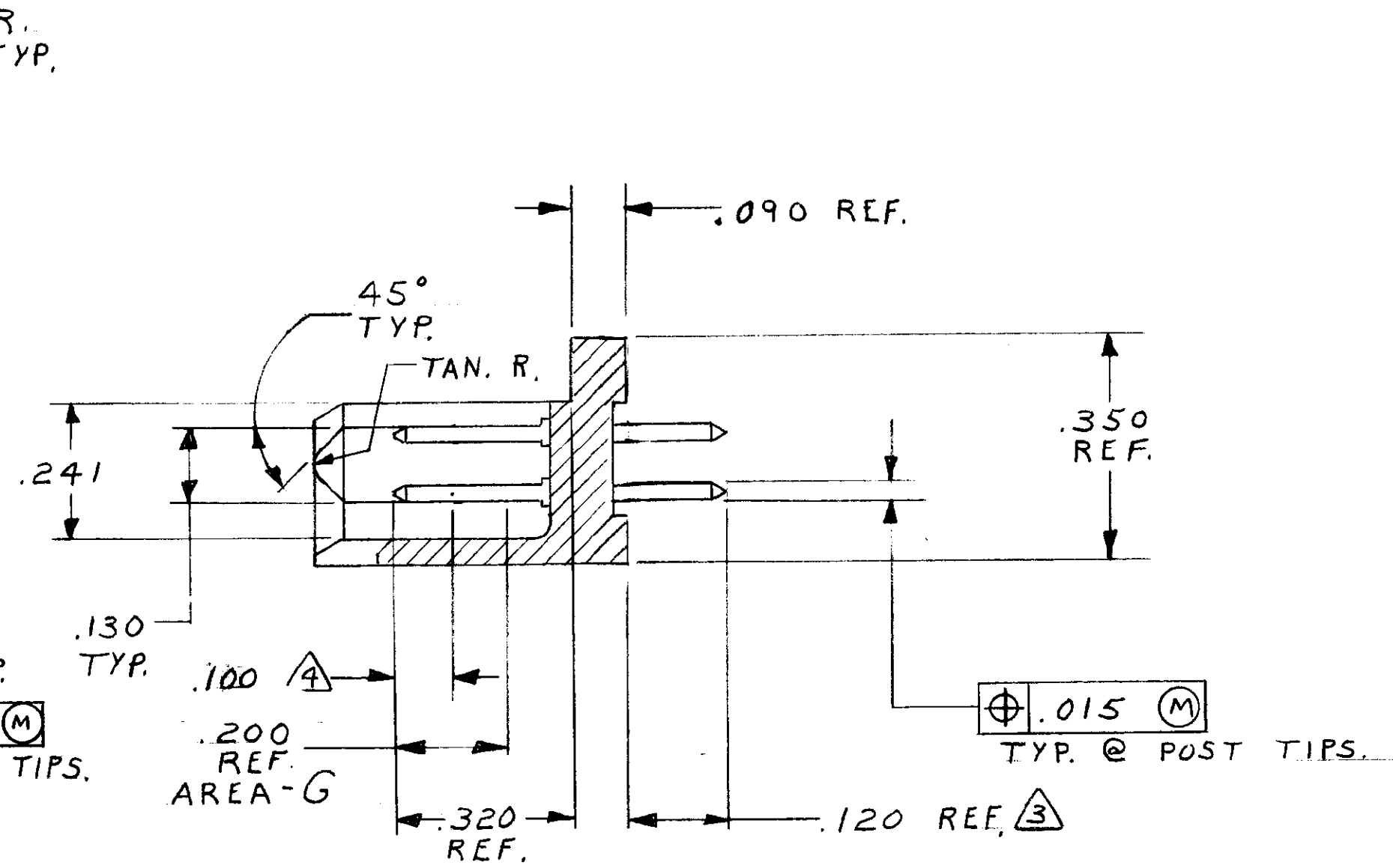
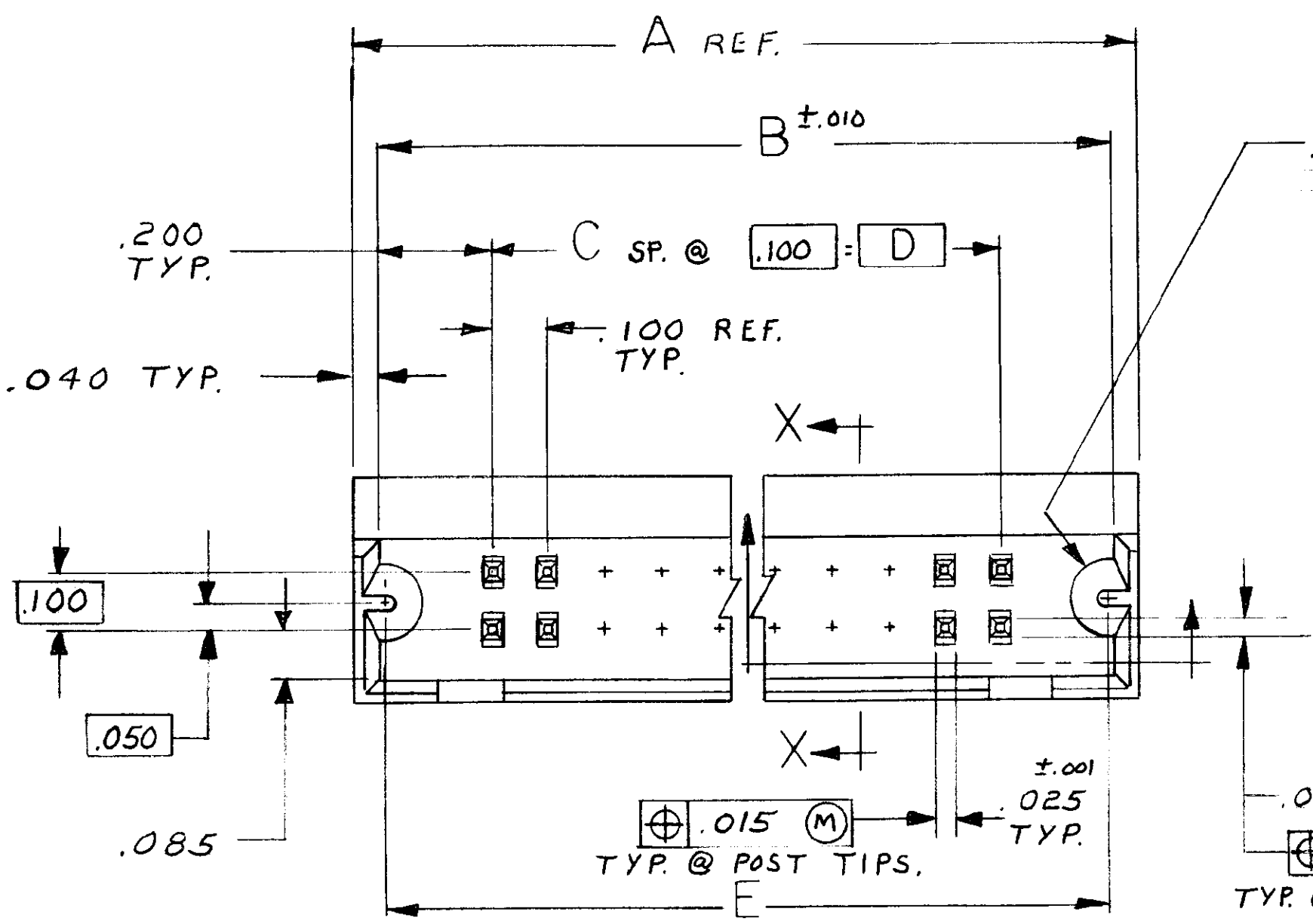

- SECTION X-X
- ① FLAME RETARDANT THERMOPLASTIC : COLOR : BLACK.
 - ② COPPER ALLOY
 - ③ .000030 GOLD OVER .000050 NICKEL AT AREA "G", .000100-.000200 BRIGHT TIN-LEAD OVER .000050 NICKEL ON SOLDER POST AREA.
 - ④ POINT OF MEASUREMENT FOR PLATING THICKNESS.
 - ⑤ RECESSED DATE CODE.

	3.870	3.500	35	3.900	3.980	72	535516-9
	5.270	4.900	49	5.300	5.380	100	535516-8
OBSOLETE	4.270	3.900	39	4.300	4.380	80	535516-7
OBSOLETE	3.770	3.400	34	3.800	3.880	70	535516-6
	3.270	2.900	29	3.300	3.380	60	535516-5
	2.270	1.900	19	2.300	2.380	40	535516-4
	2.770	2.400	24	2.800	2.880	50	535516-3
	1.270	.900	9	1.300	1.380	20	535516-2
	1.770	1.400	14	1.800	1.880	30	535516-1

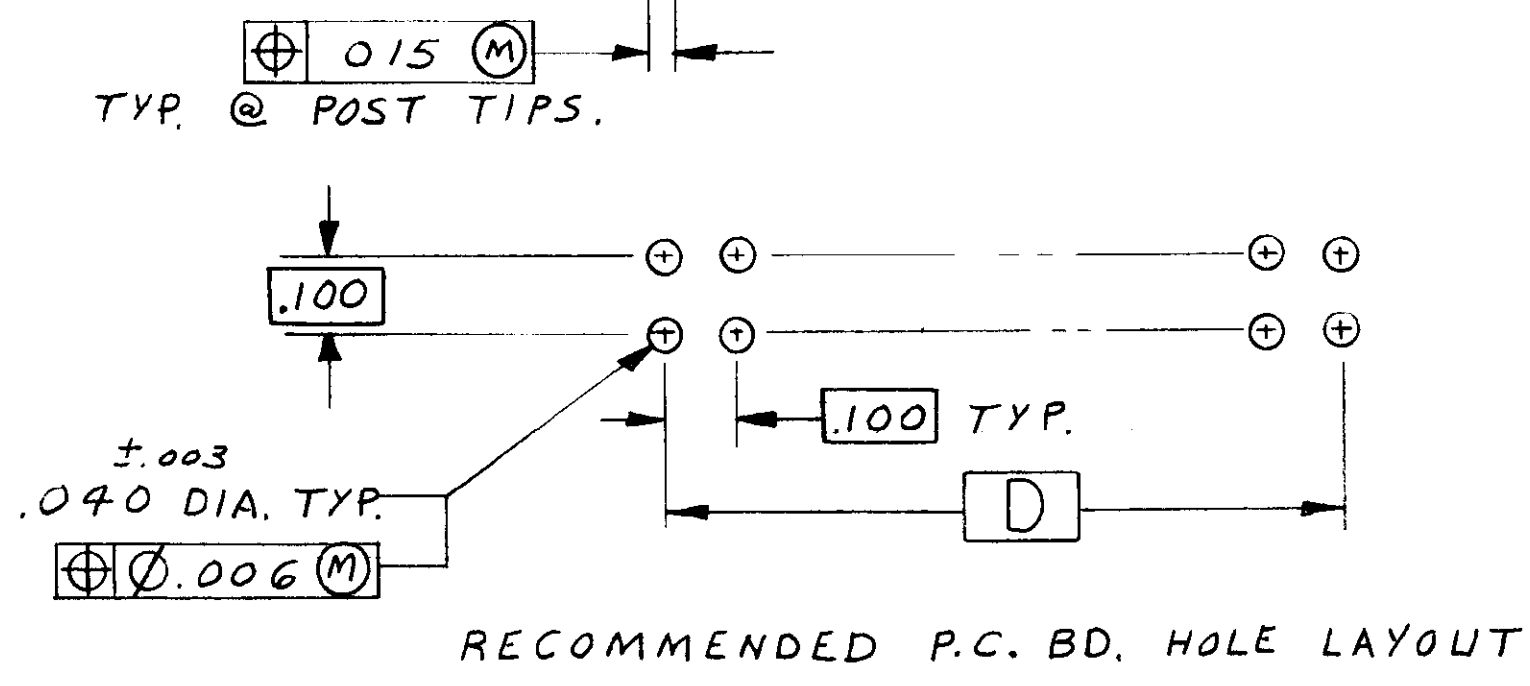

UNLESS OTHERWISE SPECIFIED DIMENSIONS ARE IN INCHES. TOLERANCES ON: DECIMALS ± .005 ANGLES	CONTRACT NO	AMP AMP INCORPORATED Harrisburg, Pa. 17105	
	MATERIAL ① HSG. ② CONT. ③ CONT.	DR <i>M. Smick</i> 3-21-88 CHKD <i>DOUGLAS R. SARVER</i> 3-21-88 APPD <i>Dough R.</i> 3-21-88 DSGN APPD <i>N. Cherry</i> 3-21-88 OTHER APPD	NAME HEADER ASSEMBLY, MOD. II, DBL. ROW, .100 x .100 @, .025 SQ. SOLDER POST.
FINISH	SIZE C	FSCM NO 00779	DRAWING NO 535516
	SCALE 4:1	SHEET #	