

PRELIMINARY

March 1993

Precision Dual and Quad Operational Amplifiers

Features

- Low Offset Voltage.....200 μ V (Max)
- Low Offset Drift 2 μ V/ $^{\circ}$ C
- Low Supply Current..... <0.7mA/Amp
- High Gain, CMRR and PSRR

Applications

- Audio Amplifiers
- Low Impedance Sensors
- Universal Active Filters
- Process Control Equipment

Description

The HA5232 and HA5234 are dual and quad precision bipolar-input op amps. They are intended for use in multichannel data acquisition systems where moderate to high level of accuracy is required. This relatively high level of accuracy is maintained across temperature with an Average Offset Drift of 2 μ V/ $^{\circ}$ C for the "A" grade product.

The HA5232 and HA5234 were designed to offer a solution/enhancement over lower performance devices like the HA-4741 and CA324. These products will allow the designer to achieve a relatively high level of precision in his transducer preamp without concern for offset trimming. These devices are pin and performance compatible with the OP200, OP400, LT1013 and LT1014 operational amplifiers.

Applications will be in process control and environment monitoring where many low impedance sensors such as thermocouples, thermistors, strain gauges, and pressure transducers are used to assess the state of the system. Other systems with similar requirements include mainframe computers, aircraft, and semiconductor fab and test equipment.

The HA5232 and HA5234 are available in industrial temperature ranges, and a choice of packages. For SOIC in tape and reel please add suffix "96" to the end of the part number.

Ordering Information

PART NUMBER	TEMPERATURE RANGE	PACKAGE
HA5232IJ	-40 $^{\circ}$ C to +85 $^{\circ}$ C	8 Lead Ceramic DIP
HA5232IP	-40 $^{\circ}$ C to +85 $^{\circ}$ C	8 Lead Plastic DIP
HA5232IB	-40 $^{\circ}$ C to +85 $^{\circ}$ C	16 Lead Wide Body SOIC
HA5232AIJ	-40 $^{\circ}$ C to +85 $^{\circ}$ C	8 Lead Ceramic DIP
HA5232AIP	-40 $^{\circ}$ C to +85 $^{\circ}$ C	8 Lead Plastic DIP
HA5232AIB	-40 $^{\circ}$ C to +85 $^{\circ}$ C	16 Lead Wide Body SOIC
HA5234IJ	-40 $^{\circ}$ C to +85 $^{\circ}$ C	14 Lead Ceramic DIP
HA5234IP	-40 $^{\circ}$ C to +85 $^{\circ}$ C	14 Lead Plastic DIP
HA5234IB	-40 $^{\circ}$ C to +85 $^{\circ}$ C	16 Lead Wide Body SOIC
HA5234AIJ	-40 $^{\circ}$ C to +85 $^{\circ}$ C	14 Lead Ceramic DIP
HA5234AIP	-40 $^{\circ}$ C to +85 $^{\circ}$ C	14 Lead Plastic DIP
HA5234AIB	-40 $^{\circ}$ C to +85 $^{\circ}$ C	16 Lead Wide Body SOIC

Pinouts

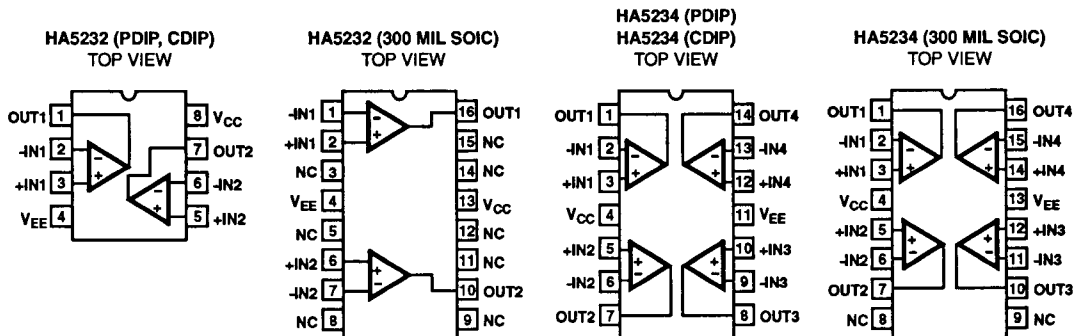

NOTE: The functional pinouts will comply to the JEDEC standards for dual and quad op amps as shown above

Specifications HA5232, HA5234

Absolute Maximum Ratings

Voltage Between V+ and V-	36V
Input Voltage	V_{SUPPLY}
Differential Input Voltage	V_{SUPPLY}
Output Current	Short Circuit Protected
Junction Temperature (Plastic)	+150°C
Junction Temperature (Hermetic)	+175°C

Operating Temperature Ranges

HA5232I, HA5234I	-40°C ≤ TA ≤ +85°C
Storage Temperature Range	-65°C ≤ TA ≤ +150°C

CAUTION: Stresses above those listed in "Absolute Maximum Ratings" may cause permanent damage to the device. This is a stress only rating and operation of the device at these or any other conditions above those indicated in the operational sections of this specification is not implied.

Electrical Specifications $V_{SUPPLY} = \pm 15V$, $R_L = 100k\Omega$, $C_L = 20pF$, Unless Otherwise Specified

PARAMETER	TEMP	HA5232A, HA5234A			HA5232, HA5234			UNITS	
		MIN	TYP	MAX	MIN	TYP	MAX		
Offset Voltage	+25°C	-	100	200	-	100	500	μV	
	Full	-	-	300	-	-	725	μV	
Average Offset Drift	Full	-	-	2	-	-	5	μV/°C	
Input Bias Current	+25°C	-	5	-	-	10	-	nA	
	Full	-	-	-	-	-	-	nA	
Input Offset Current	+25°C	-	3.5	-	-	10	-	nA	
	Full	-	-	-	-	-	-	nA	
Common Mode Range	Full	±12	-	-	±12	-	-	V	
CMRR (Note 1)	+25°C	110	-	-	100	-	-	dB	
	Full	105	-	-	100	-	-	dB	
Input Capacitance	+25°C	-	3	-	-	3	-	pF	
Input Noise Voltage	0.1Hz - 10Hz	+25°C	-	0.5	-	0.5	-	μV _{p-p}	
	$f_o = 1kHz$	+25°C	-	11	-	11	-	nV/√Hz	
Input Noise Current	0.1Hz - 10Hz	+25°C	-	15	-	15	-	pA _{p-p}	
	$f_o = 1kHz$	+25°C	-	0.4	-	0.4	-	pA/√Hz	
Large Signal Gain (Note 2)	+25°C	1000	-	-	250	-	-	KV/V	
	Full	1000	-	-	250	-	-	KV/V	
Unity Gain Bandwidth	+25°C	-	0.8	-	-	0.8	-	MHz	
Minimum Stable Gain	Full	1	-	-	1	-	-	V/V	
Output Swing (Note 2)	Full	12	-	-	12	-	-	V	
Short Circuit Current	Full	-	20	-	-	20	-	mA	
Slew Rate (Note 3)	+25°C	-	0.15	-	-	0.15	-	V/μs	
PSRR (Note 4)	+25°C	105	-	-	100	-	-	dB	
	Full	100	-	-	100	-	-	dB	
I_{CC}	HA5232	+25°C	-	-	1.45	-	-	1.45	mA
		Full	-	-	1.55	-	-	1.55	mA
	HA5234	+25°C	-	-	2.9	-	-	2.9	mA
		Full	-	-	3.1	-	-	3.1	mA

NOTES:

1. $V_{CM} = \pm 12V$
2. $R_L = 2K$
3. $R_L = 2K$, $C_L = 100pF$, $V_{OUT} = \pm 10V$, $A_V = +1$
4. $|V_{S}| = 3V$ to $18V$

Schematic

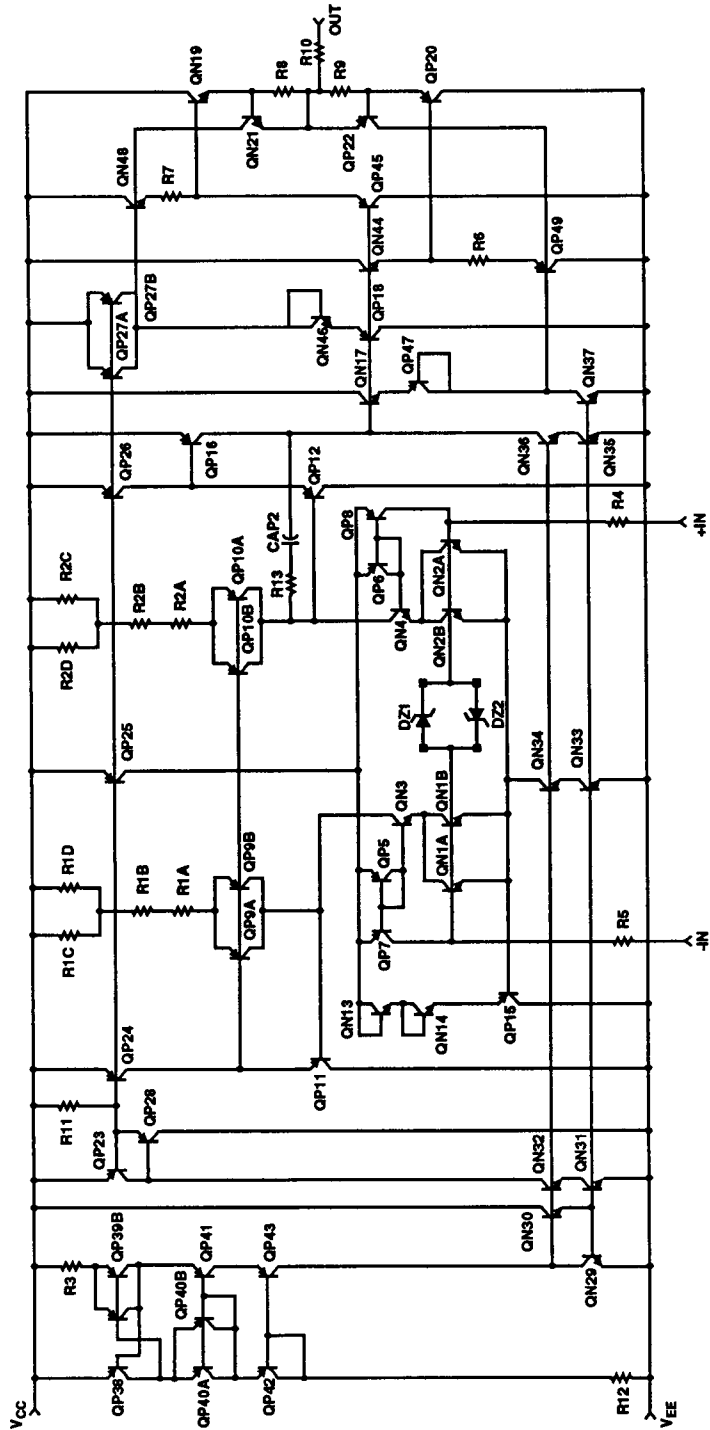

HA5232

Die Characteristics

DIE DIMENSIONS:

87 x 105 x 21 ± 1mils

METALLIZATION:

Type: Al

Thickness: 19kÅ ± 4kÅ

GLASSIVATION:

Type: Silox (SiO₂)

Thickness: 13.5kÅ ± 2kÅ

DIE ATTACH:

Material: Silver Epoxy - Plastic DIP and SOIC

Glass - Ceramic DIP

Metallization Mask Layout

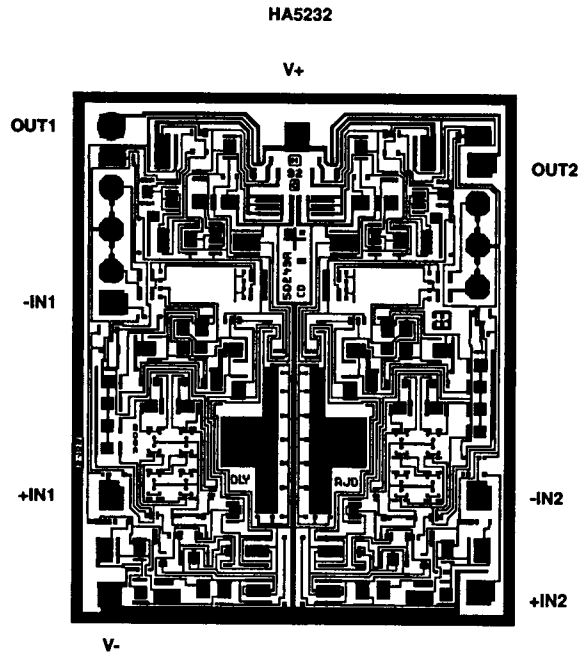

Die Characteristics

DIE DIMENSIONS:

114 x 157 x 21 ± 1mils

METALLIZATION:

Type: Al

Thickness: 19kÅ ± 4kÅ

GLASSIVATION:

Type: Silox (SiO₂)

Thickness: 13.5kÅ ± 2kÅ

DIE ATTACH:

Material: Silver Epoxy - Plastic DIP and SOIC

Glass - Ceramic DIP

Metallization Mask Layout

