

General Description

The MIC4401/4402 are BiCMOS/DMOS buffer-drivers constructed with complementary MOS outputs, where the drains of the final output totem poles have been left disconnected so individual connections can be made to the pull-up and pull-down sections of the output, thus allowing the user to define the rates of rise and fall times desired for a capacitive load, or a reduced output swing if driving a resistive load, or to limit base current when driving a bipolar transistor. Minimum rise and fall times, with no resistors, will be less than 30ns for a 10,000pF load. There is no upper limit.

These devices are rugged due to extra steps taken to protect them from failures. A modern Bipolar/CMOS/DMOS process guarantees freedom from latchup. Proprietary circuits allow the input to swing negative as much as 5V without damaging the part.

For driving MOSFETs in motor-control applications, where slow-on/fast-off operation is desired, the MIC4401/4402 is superior to the previously-used technique of adding a diode-resistor combination between the driver output and the MOSFET, because it allows accurate control of turn-on, while maintaining fast turn-off and maximum noise immunity for the device being driven.

Features

- Independently Programmable Rise and Fall Times
- High Peak Output Current 6A peak
- Low Output Impedance 1.7Ω typ
- High Speed t_R , t_F <20 ns with 2500pF load
- Short Delay Times 25ns Typical
- Wide Operating Range 4.5V to 18V
- Latch-up Protected: Fully Isolated Process is Inherently Immune to any Latchup.
- Input Withstands Negative Swings to -5V
- ESD Protected 2kV

Applications

- Motor Controls
- Self-Commutating MOSFET Bridge Driver
- Driving Bipolar Transistors
- Driver for Non-overlapping Totem Poles
- Reach-Up/Reach-Down Driver

Functional Diagram

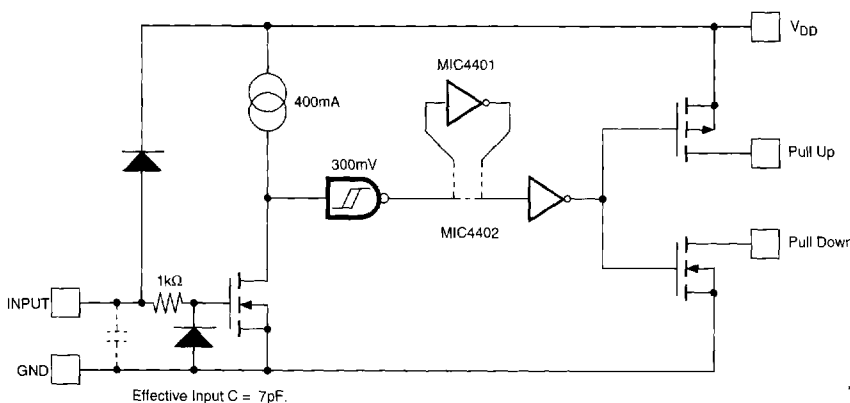

Pin Configuration

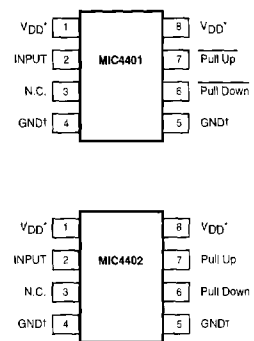

* Pins 1 and 8 must be externally connected for proper operation.

† Pins 4 & 5 must be externally connected for proper operation.

When used to drive bipolar transistors, this driver maintains high speeds and allows insertion of a base current-limiting resistor, and also provides a separate half-output for fast turn-off. By proper positioning of the resistor, either NPN or PNP transistors can be driven.

For driving many loads in low-power systems, this driver, since it has very low quiescent current (80 μ A) and eliminates shoot-through current in the output stage, requires significantly less power than other drivers. This can be helpful in meeting low-power budgets.

Due to independent drains, this device can also be used as an open-drain buffer/driver where both drains are available in one device, thus minimizing chip count. An unused pull-down should be returned to the ground; an unused pull-up should be returned to V_{DD} . This is to prevent static damage. Alternatively, in situations requiring greater current-carrying capacity, multiple MIC4608 or MIC4608s may be paralleled.

The MIC4608/4609 will not latch under any conditions within its power and voltage ratings. It is not subject to damage when up to 5V of noise spiking of either polarity occurs on the ground pin. It can accept, without damage or logic upset, up to 1.5 amps of reverse current (of either polarity) being forced back into the outputs.

Absolute Maximum Ratings (Note 1)

Supply Voltage	+22V
Logic Input Voltage	$V_{DD} + 0.3V$ to $GND - 5V$
Logic Input Current ($V_{IN} > V_{DD}$)	50mA
Maximum Die Temperature	+150°C
Storage Temperature Range	-65°C to +150°C
Lead Temperature (Soldering, 10 sec)	+300°C
Power Dissipation, $T_A \leq 25^\circ\text{C}$	
PDIP	1W
SOIC	500mW
CerDIP	800mW
Package Thermal Resistance	
CerDIP θ_{JA}	150°C/W
CerDIP θ_{JC}	55°C/W
PDIP θ_{JA}	125°C/W
PDIP θ_{JC}	45°C/W
SOIC θ_{JA}	160°C/W
SOIC θ_{JC}	75°C/W

Ordering Information

Part Number	Logic	Package	Temperature Range
MIC4401AJ	Inverting	8-pin CerDIP	-55°C to +125°C
MIC4401BN	Inverting	8-pin PDIP	-40°C to +85°C
MIC4401BM	Inverting	8-pin SOIC	-40°C to +85°C
MIC4401CN	Inverting	8-pin PDIP	0°C to +70°C
MIC4402AJ	Non-Inverting	8-pin CerDIP	-55°C to +125°C
MIC4402BN	Non-Inverting	8-pin PDIP	-40°C to +85°C
MIC4402BM	Non-Inverting	8-pin SOIC	-40°C to +85°C
MIC4402CN	Non-Inverting	8-pin PDIP	0°C to +70°C

Note 1: Stresses above those listed under Absolute Maximum Ratings may cause permanent damage to the device. These are stress ratings only and functional operation of the device at these or any other conditions above those indicated in the operational sections of the specification is not implied. Exposure to Absolute Maximum Rating Conditions for extended periods may affect device reliability. Static-sensitive device. Unused devices must be stored in conductive material. Protect devices from static discharge and static fields.

Electrical Characteristics

Unless otherwise specified, specifications measured at $T_A = 25^\circ\text{C}$ with $4.5\text{V} \leq V_{DD} \leq 18\text{V}$.

Symbol	Parameter	Test Conditions	Min	Typ	Max	Unit
Input						
V_{IH}	Logic 1 High Input Voltage		2.4		$V_{DD} + 0.3$	V
V_{IL}	Logic 0 Low Input Voltage		-5		0.8	V
I_{IN}	Input Current	$0\text{V} \leq V_{IN} \leq V_{DD}$	-10		10	μA
Output						
V_{OH}	High Output Voltage		$V_{DD} - 0.025$			V
V_{OL}	Low Output Voltage				0.025	V
R_O	Output Resistance, Pull-Up	$I_{OUT} = 10\text{mA}, V_{DD} = 18\text{V}$		1.5	2.8	Ω
R_O	Output Resistance, Pull-Down	$I_{OUT} = 10\text{mA}, V_{DD} = 18\text{V}$		1.7	2.5	Ω
I_{PK}	Peak Output Current			6		A
I_R	Latch-up Protection Withstand Reverse Current		>1500			mA
Switching Time						
t_R	Rise Time	Figure 1, $C_L = 2500\text{pF}$		12	35	ns
t_F	Fall Time	Figure 1, $C_L = 2500\text{pF}$		13	35	ns
t_{D1}	Delay Time	Figure 1, $C_L = 2500\text{pF}$		18	75	ns
t_{D2}	Delay Time	Figure 1, $C_L = 2500\text{pF}$		48	75	ns
Power Supply						
I_S	Power Supply Current	$V_{IN} = 3\text{V}$		0.45	1.5	mA
		$V_{IN} = 0\text{V}$		0.09	0.15	mA

6

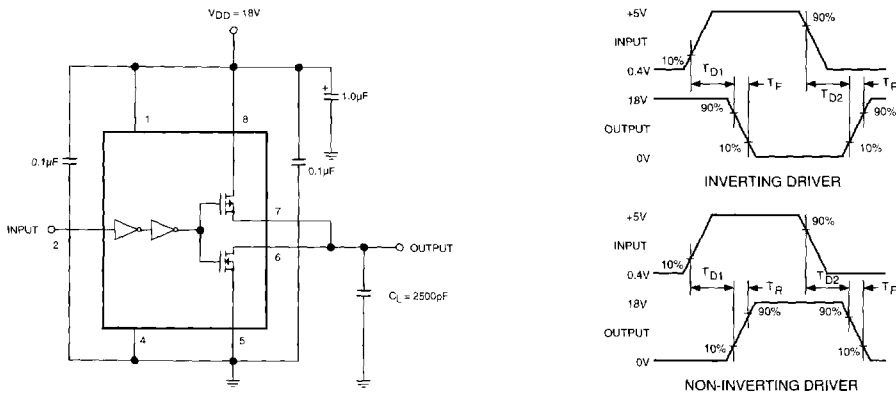

Figure 1. MIC4401/4402 Switching time test circuit.

Electrical Characteristics, continued

Specifications measured **over operating temperature range** with $4.5V \leq V_{DD} \leq 18V$, unless otherwise specified.

Symbol	Parameter	Test Conditions	Min	Typ	Max	Unit
Input						
V_{IH}	Logic 1 High Input Voltage		2.4			V
V_{IL}	Logic 0 Low Input Voltage				0.8	V
I_{IN}	Input Current	$0V \leq V_{IN} \leq V_{DD}$	-10		10	μA
Output						
V_{OH}	High Output Voltage		$V_{DD} - 0.025$			V
V_{OL}	Low Output Voltage				0.025	V
R_O	Output Resistance, Pull-Up	$I_{OUT} = 10mA, V_{DD} = 18V$		2.2	5	Ω
R_O	Output Resistance, Pull-Down	$I_{OUT} = 10mA, V_{DD} = 18V$		3.5	5	Ω
Switching Time						
t_R	Rise Time	Figure 1, $C_L = 2500pF$		16	60	ns
t_F	Fall Time	Figure 1, $C_L = 2500pF$		25	60	ns
t_{D1}	Delay Time	Figure 1, $C_L = 2500pF$		25	100	ns
t_{D2}	Delay Time	Figure 1, $C_L = 2500pF$		70	100	ns
Power Supply						
I_S	Power Supply Current	$V_{IN} = 3V$		0.5	3	mA
		$V_{IN} = 0V$		0.12	0.4	mA