

400mA Low Dropout Linear Regulator with Voltage Detector Function

■ FEATURES

- Including MOSFET for V_{OUT1} , LDO for V_{OUT2} , voltage detector, and shutdown control
- Low Dropout Voltage of 550mV(Typ.) at 400mA Output Current (V_{OUT2}).
- Guaranteed 700mA Output Current for V_{OUT1} and 400mA for V_{OUT2} .
- Low Ground Current at 120 μ A.
- 2% Accuracy Output Voltage of V_{OUT2} .
- Current Limit Function.
- Built in Voltage Detector
- Shutdown Control for V_{OUT1} and V_{OUT2}

■ APPLICATIONS

- Voltage Regulator for DVD-ROM and CD-ROM Drivers.
- Voltage Regulator for HDD and Floppy Drivers.
- Voltage Regulator for circuits with Stepping Motor or Servo Motor.

■ DESCRIPTION

The AIC1729 is a low dropout linear regulator with voltage detection function.

It can be divided into 4 main function blocks, including MOSFET for V_{OUT1} , LDO for V_{OUT2} , voltage detector, and two shutdown controls.

Voltage detector can be use to detect V_{CC} . The detecting voltage of the voltage detector is from 3.0V to 4.6V with 0.1V step. And the output (DOUT) of detecting voltage for V_{CC} with delay time adjustment function to indicate V_{CC} low. User only adds one external capacitor to finish it. When V_{CC} pin is under the set detection voltage. DOUT pin is logic low.

V_{OUT1} is controlled by SD1 pin. When SD1 is logic high, the internal MOSFET for V_{OUT1} will be switched off, vice versa.

The LDO output voltage (V_{OUT2}) is from 1.8V to 4.0V with 0.1V step for different application. It is also controlled by SD2 pin. When SD2 is logic high, the internal LDO for V_{OUT2} will be shutdown, vice versa.

The superior characteristics of the AIC1729 include very low dropout voltage, and 2% accuracy output voltage. Typical ground current remains 120 μ A, from no load to maximum loading conditions. Dropout voltage of V_{OUT2} is 550mV at 400mA output current. Output current limiting is provided at V_{OUT1} and V_{OUT2} .

AIC1729 comes in the popular SO8 package.

TYPICAL APPLICATION CIRCUIT

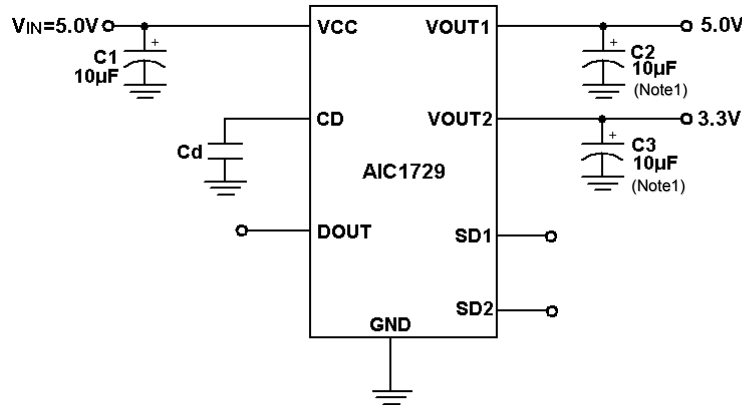

Power Source for CD-drivers and DVD-drivers

ORDERING INFORMATION

AIC1729-XX XXXXXX

PACKING TYPE
 TB: TUBE
 TR: TAPE & REEL (not available for DIP-8 package)

PACKAGE TYPE
 N: DIP-8
 S: SOP-8

C: Commercial
 P: Lead Free Commercial

LDO OUTPUT VOLTAGE
 18: 1.8V
 ...
 40: 4.0V

VOLTAGE DETECTOR VOLTAGE
 30: 3.0V
 ...
 46: 4.6V

* LDO Output Voltage and Voltage Detector voltage with every 0.1V a step.

Example: AIC1729-3018CN

→ 3.0V Voltage Detector Voltage, 1.8V LDO Output Voltage, in DIP-8 Package Type

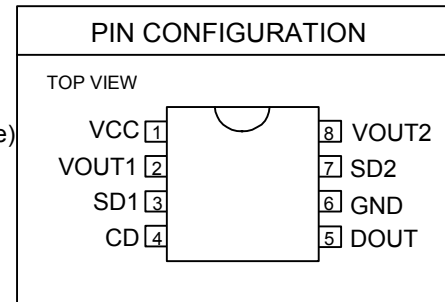

■ ABSOLUTE MAXIMUM RATINGS

Input Supply Voltage	-0.3~8V
Control Input (V _{CTL})	-0.3V ~7V
Operating Temperature Range	-40°C~85°C
Junction Temperature	125°C
Storage Temperature Range	-65°C ~ 150°C
Lead Temperature (Soldering, 10sec)	260°C
Thermal Resistance, R _{JC} (Junction to Case)	DIP-8.....	60°C /W
	SOP-8.....	40°C /W
Thermal Resistance, R _{JA} (Junction to Ambient)	DIP-8.....	100°C/W
(Assume no Ambient Airflow, no heatsink)	SOP-8.....	160°C/W

Absolute Maximum Ratings are those values beyond which the life of a device may be impaired.

■ ELECTRICAL CHARACTERISTICS (T_A=25°C, V_{IN}=5.0V, I_{OUT1}=I_{OUT2}=400mA, SD1=SD2=Low, unless otherwise specified.) (Note2)

PARAMETER	TEST CONDITIONS	MIN.	TYP.	MAX.	UNIT
Ground Current	I _{OUT1} =0.1mA~700mA I _{OUT2} =0.1mA~400mA V _{IN} = 4.0V~8.0V		120	200	μA
Output Voltage Temperature Coefficiency	(Note 3)		100		PPM/°C
VOUT1					
Output MOSFET Resistance	V _{IN} = 5.0V		370	450	mΩ
Current Limit(Note 4)		700	950		mA
Output Turn-on Rise Delay			100		μS
Output Turn-on Rise Time			1000		μS
SD1 Pin Voltage	V _{SD} =Logic"0"			0.8	V
	V _{SD} =Logic"1"	2.4			
VOUT2 (1.8V ~ 4.0V with 0.1V step)					
LDO Output Voltage	No Load	V _{SET} × 0.98	V _{SET}	V _{SET} × 1.02	V
Line Regulation	I _L =1mA, V _{IN} =4.0V~8.0V		3	10	mV
Load Regulation (Note 5)	V _{IN} =5V, I _L =0.1mA~400mA		50	90	mV
Current Limit (Note 4)		400	650		mA

ELECTRICAL CHARACTERISTICS (Continued)

PARAMETER	TEST CONDITIONS	MIN.	TYP.	MAX.	UNIT
Dropout Voltage (Note 6)	$V_{OUT} \geq 3.3V$	$I_L=100mA$	140	200	mV
		$I_L=200mA$	280	350	
		$I_L=300mA$	420	500	
		$I_L=400mA$	550	700	
	$2.5V \leq V_{OUT} < 3.3V$	$I_L=100mA$	250	300	
		$I_L=200mA$	420	500	
		$I_L=300mA$	600	700	
		$I_L=400mA$	780	900	
	$V_{OUT} < 2.5V$	$I_L=100mA$	700	800	
		$I_L=200mA$	880	950	
		$I_L=300mA$	1050	1150	
		$I_L=400mA$	1220	1400	
SD2 Pin Voltage	$V_{SD}=\text{Logic}''0''$			0.8	V
	$V_{SD}=\text{Logic}''1''$	2.4			
Voltage Detector (3.0V ~ 4.6V with 0.1V step)					
Detect Voltage(V_{DET})		$V_{DSET} \times 0.98$	V_{DSET}	$V_{DSET} \times 1.02$	V
Detect Threshold Hysteresis			$V_{DET} \times 1.05$		V
V_{DOUT}	When V_{DET} is Detected			0.6	V
	When V_{DET} is not Detected	1.65			
Delay Time	CD Pin Open		1	3	mS

Note 1: To avoid output oscillation, aluminum electrolytic output capacitor is recommended and ceramic capacitor is not suggested.

Note 2: Specifications are production tested at $T_A=25^\circ C$. Specifications over the $-40^\circ C$ to $85^\circ C$ operating temperature range are assured by design, characterization and correlation with Statistical Quality Controls (SQC).

Note 3: Guaranteed by design.

Note 4: Current limit is measured by pulsing a short time.

Note 5: Regulation is measured at constant junction temperature, using pulse testing with a low ON time.

Note 6: Dropout voltage is defined as the input to output differential at which the output voltage drops 100mV below the value measured with a 1V differential.

TYPICAL PERFORMANCE CHARACTERISTICS

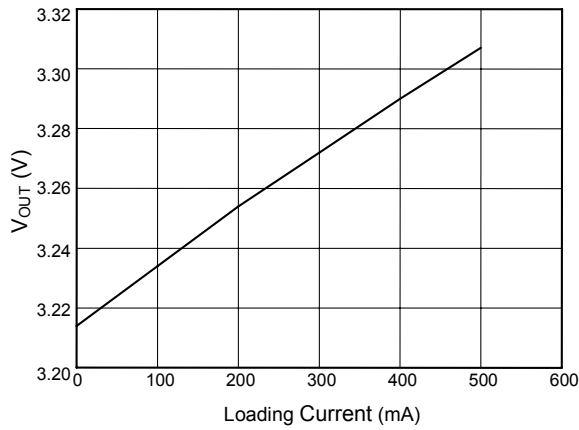

Fig. 1 Output voltage vs. Loading Current

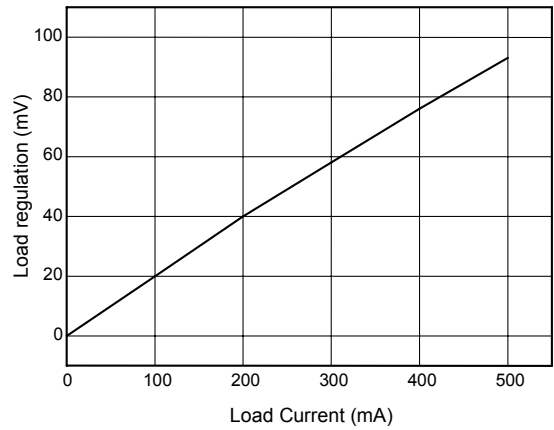

Fig. 2 Load Regulation

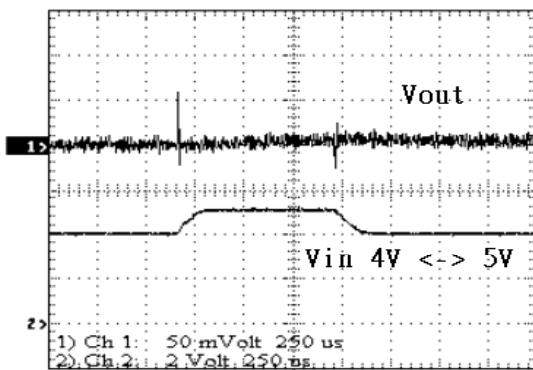

Fig. 3 Line Transient

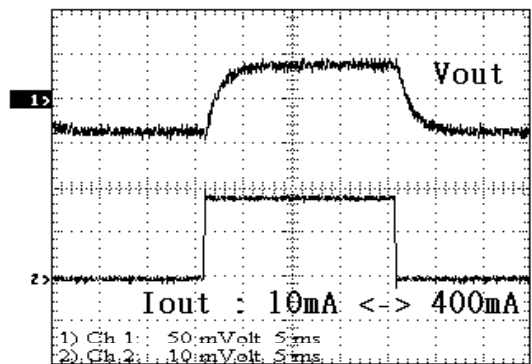

Fig. 4 Load Transient

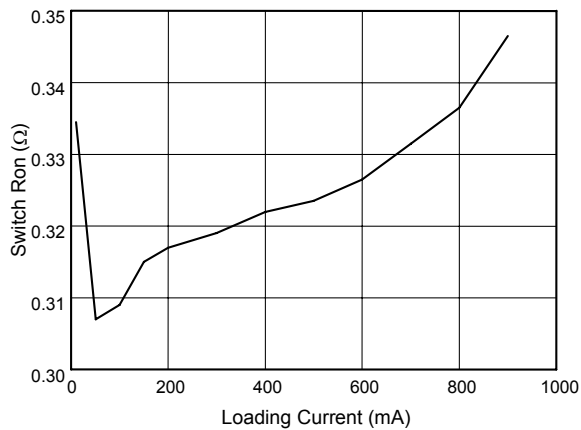

Fig. 5 Switch Ron vs. Loading current (mA)

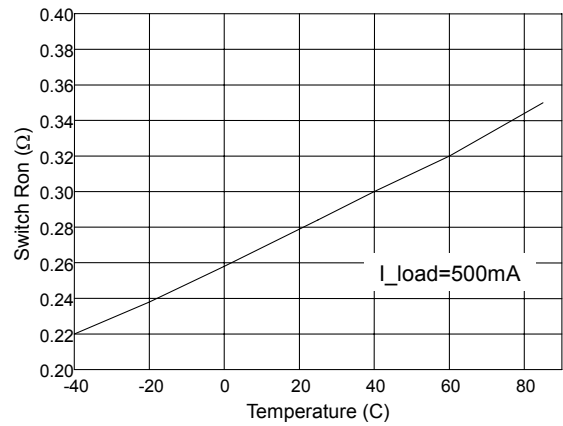

Fig. 6 Switch Ron vs. Temperature

TYPICAL PERFORMANCE CHARACTERISTICS (Continued)

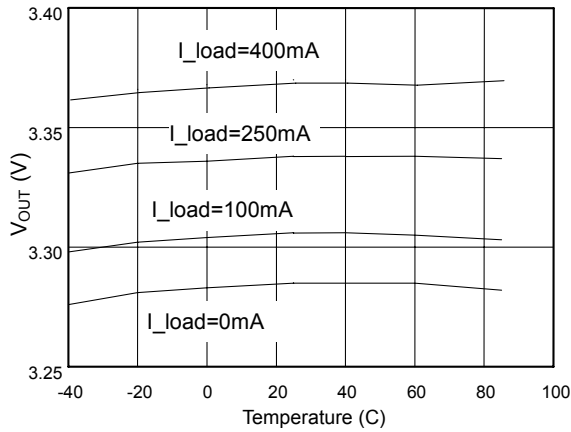

Fig. 7 Output voltage vs. Temperature

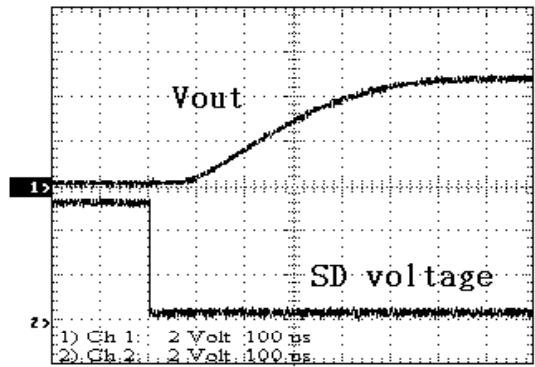

Fig. 8 Output Turn-on Rise Time

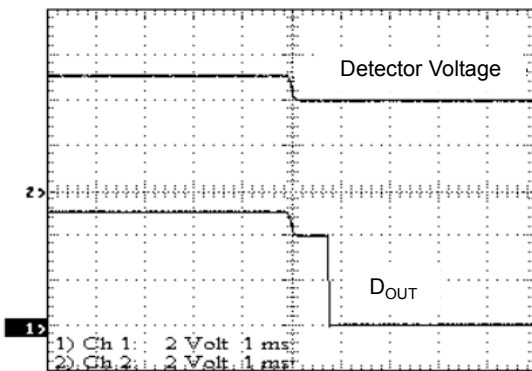

Fig. 9 Built-in Delay Time Waveform

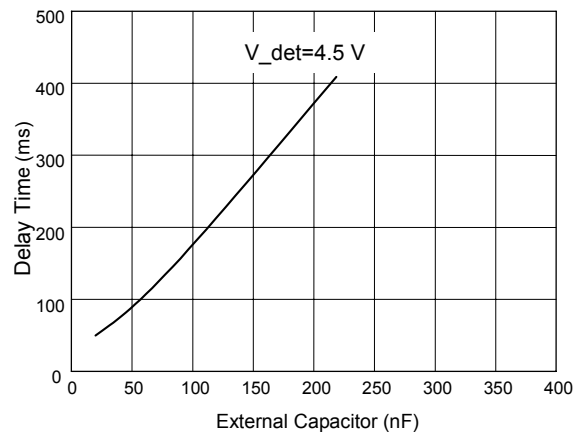
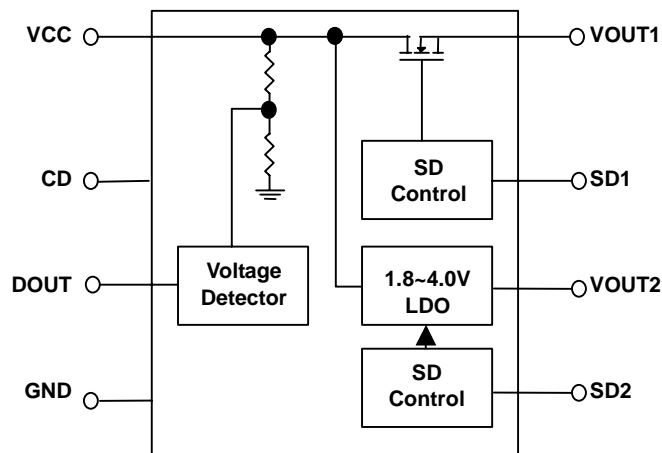

Fig. 10 Delay Time vs. External Capacitor

BLOCK DIAGRAM



■ PIN DESCRIPTION

- PIN 1: VCC- This pin is the main input supply for the IC, normally 5V
- PIN 2: VOUT1- This pin is the voltage output which is connected to Vcc directly via internal MOSFET switch, normally 5V
- PIN 3: SD1- VOUT1 shutdown pin. Logic high input for disabling the internal MOS Switch.
- PIN 4: CD- This pin is to determine delay time by attaching a capacitor
- PIN 5: DOUT- This pin is voltage detector output, pulled low when V_{IN} detected
- PIN 6: GND- IC ground pin
- PIN 7: SD2- VOUT2 shutdown pin. Logic high input for disabling LDO output.
- PIN 8: VOUT2- This pin is 3.3V LDO voltage output

■ APPLICATION INFORMATION

INPUT-OUTPUT CAPACITORS

Linear regulators require input and output capacitors to maintain stability. Input capacitor at 10 μ F with 10uF aluminum electrolytic output capacitor is recommended.

POWER DISSIPATION

The maximum power dissipation of AIC1729 depends on the thermal resistance of its case and circuit board, the temperature difference between the die junction and ambient air, and the rate of airflow. The rate of temperature rise is greatly affected by the mounting pad configuration on the PCB, the board material, and the ambient temperature. When the IC mounting with good thermal conductivity is used, the junction temperature will be low even when large power dissipation applies.

The power dissipation across the device is

$$P = I_{OUT} (V_{IN} - V_{OUT}).$$

The maximum power dissipation is:

$$P_{MAX} = \frac{(T_{J-max} - T_A)}{R\theta_{JA}}$$

Where T_{J-max} is the maximum allowable junction temperature (125°C), and T_A is the ambient temperature suitable in application.

As a general rule, the lower temperature is, the better reliability of the device is. So the PCB mounting pad should provide maximum thermal conductivity to maintain low device temperature.

GND pin performs a dual function for providing an electrical connection to ground and channeling heat away. Therefore, connecting the GND pin to ground with a large pad or ground plane would increase the power dissipation and reduce the device temperature.

■ **PHYSICAL DIMENSIONS** (unit: mm)

● SOP-8

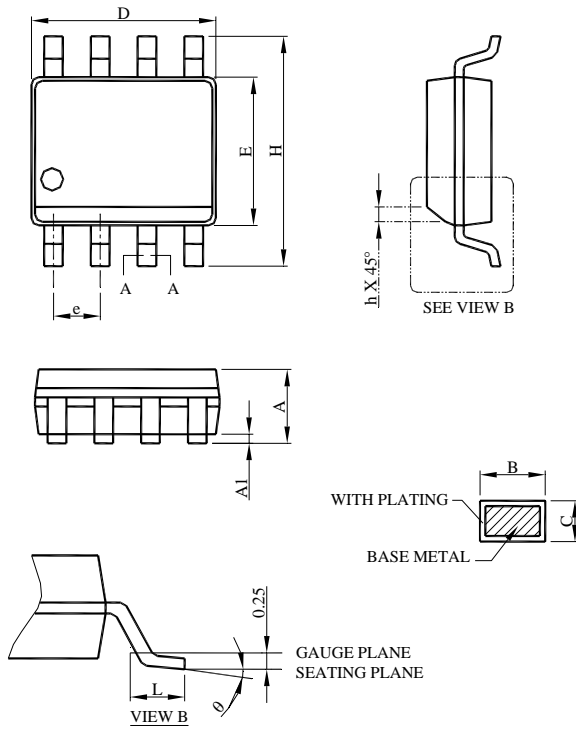

SYMBOL	SOP-8	
	MILLIMETERS	
	MIN.	MAX.
A	1.35	1.75
A1	0.10	0.25
B	0.33	0.51
C	0.19	0.25
D	4.80	5.00
E	3.80	4.00
e	1.27 BSC	
H	5.80	6.20
h	0.25	0.50
L	0.40	1.27
θ	0°	8°

Note:

- 1.Refer to JEDEC MS-012AA.
- 2.Dimension "D" does not include mold flash, protrusions or gate burrs. Mold flash, protrusion or gate burrs shall not exceed 6 mil per side.
- 3.Dimension "E" does not include inter-lead flash or protrusions. Inter-lead flash or protrusion shall not exceed 10 mil per side.
- 4.Controlling dimension is millimeter, converted inch dimensions are not necessarily exact.

● DIP-8

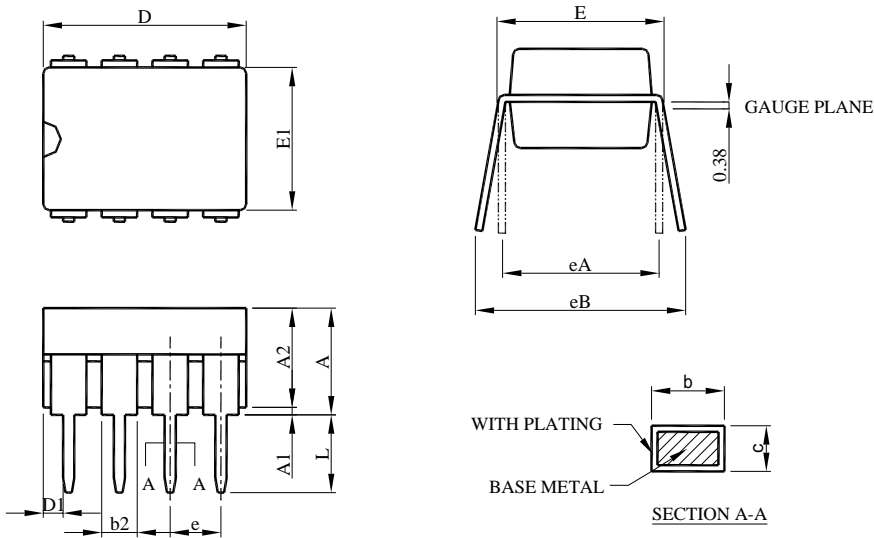

SYMBOL	DIP-8	
	MILLIMETERS	
	MIN.	MAX.
A		5.33
A1	0.38	
A2	2.92	4.95
b	0.36	0.56
b2	1.14	1.78
c	0.20	0.35
D	9.01	10.16
D1	0.13	
E	7.62	8.26
E1	6.10	7.11
e	2.54 BSC	
eA	7.62 BSC	
eB		10.92
L	2.92	3.81

Note:

1. Refer to JEDEC MS-001BA.
2. Dimension D, D1 and E1 do not include mold flash or protrusions. Mold flash or protrusion shall not exceed 10 mil.
3. Controlling dimension is millimeter, converted inch dimensions are not necessarily exact.

Note:

Information provided by AIC is believed to be accurate and reliable. However, we cannot assume responsibility for use of any circuitry other than circuitry entirely embodied in an AIC product; nor for any infringement of patents or other rights of third parties that may result from its use. We reserve the right to change the circuitry and specifications without notice.

Life Support Policy: AIC does not authorize any AIC product for use in life support devices and/or systems. Life support devices or systems are devices or systems which, (i) are intended for surgical implant into the body or (ii) support or sustain life, and whose failure to perform, when properly used in accordance with instructions for use provided in the labeling, can be reasonably expected to result in a significant injury to the user.