

SURFACE MOUNT
GLASS PASSIVATED ZENER SILICON RECTIFIER
VOLTAGE RANGE 6.2 TO 91.0 Volts STEADY STATE POWER 1.0 WATT

FEATURES

- * Plastic package has underwriters laboratory
- * Excellent clamping capability
- * Low zener impedance
- * Low regulation factor

MECHANICAL DATA

- * Epoxy : Device has UL flammability classification 94V-0

MAXIMUM RATINGS AND ELECTRICAL CHARACTERISTICS

Ratings at 25 °C ambient temperature unless otherwise specified.

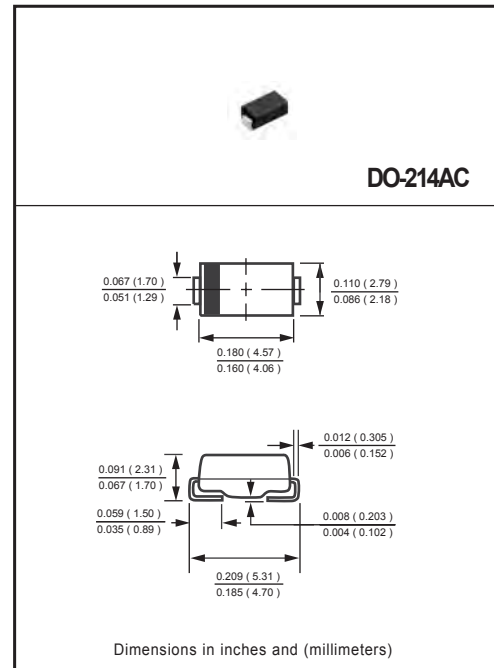

MAXIMUM RATINGS (@ TA = 25°C unless otherwise noted)

CHARACTERISTICS	SYMBOL	Ratings	UNITS
Power Dissipation	PTOT	1	W
Thermal Resis	R _{thJA}	170	K / mW
Tolerance	-	5	%
Forward Voltage@If = 100mA	Vf	1.0	V
Junction Temp	T _J	-55 to 150	°C
Storage Temp	T _{stg}	-55 to 150	°C

ELECTRICAL CHARACTERISTICS (@ TA = 25°C unless otherwise noted)

TYPE	NOMINAL ZENER VOLTAGE			TEST CURRENT (mA)	MAXIMUM DYNAMIC IMPEDANCE				MAXIMUM DC REVERSE LEAKAGE CURRENT		MAXIMUM SURGE CURRENT (NOTE 2) IRM (mApk)	MAXIMUM FORWARD VOLTAGE VF at 200mA (Volts)
	VZ at IZT (NOTE 1) (Volts)				IZT (mA)	ZZT at IZT (ohms)	ZZK at IZK (ohms)	(NOTE 1) IZK (mA)	IR (uA)	VR (Volts)		
	Min.	Typ.	Max.									
FM4735W	5.58	6.2	6.82	41.0	2.0	700	1.00	50.0	3.0	730.0	1.2	
FM4735AW	5.89	6.2	6.51	41.0	2.0	700	1.00	50.0	3.0	730.0	1.2	
FM4736W	6.12	6.8	7.48	37.0	3.5	700	1.00	10.0	4.0	660.0	1.2	
FM4736AW	6.46	6.8	7.14	37.0	3.5	700	1.00	10.0	4.0	660.0	1.2	
FM4737W	6.75	7.5	8.25	34.0	4.0	700	0.50	10.0	5.0	605.0	1.2	
FM4737AW	7.13	7.5	7.88	34.0	4.0	700	0.50	10.0	5.0	605.0	1.2	
FM4738W	7.38	8.2	9.02	31.0	4.5	700	0.50	10.0	6.0	550.0	1.2	
FM4738AW	7.79	8.2	8.61	31.0	4.5	700	0.50	10.0	6.0	550.0	1.2	
FM4739W	8.19	9.1	10.01	28.0	5.0	700	0.50	10.0	7.0	500.0	1.2	
FM4739AW	8.65	9.1	9.56	28.0	5.0	700	0.50	10.0	7.0	500.0	1.2	
FM4740W	9.0	10.0	11.0	25.0	7.0	700	0.25	10.0	7.6	454.0	1.2	
FM4740AW	9.5	10.0	10.5	25.0	7.0	700	0.25	10.0	7.6	454.0	1.2	

ELECTRICAL CHARACTERISTICS (At $T_A = 25^\circ\text{C}$ unless otherwise noted)

TYPE	NOMINAL ZENER VOLTAGE			TEST CURRENT	MAXIMUM DYNAMIC IMPEDANCE			MAXIMUM DC REVERSE LEAKAGE CURRENT		MAXIMUM SURGE CURRENT (NOTE 2) IRM (mApk)	MAXIMUM FORWARD VOLTAGE VF at 200mA (Volts)
	VZ at IZT (NOTE 1) (Volts)				IZT (mA)	ZZT at IZT (ohms)	ZZK at IZK (ohms)	(NOTE 1) IZK (mA)	IR (uA)		
	Min.	Typ.	Max.								
FM4741W	9.9	11.0	12.1	23.0	8.0	700	0.25	5.0	8.4	414.0	1.2
FM4741AW	10.45	11.0	11.55	23.0	8.0	700	0.25	5.0	8.4	414.0	1.2
FM4742W	10.8	12.0	13.2	21.0	9.0	700	0.25	5.0	9.1	380.0	1.2
FM4742AW	11.4	12.0	12.6	21.0	9.0	700	0.25	5.0	9.1	380.0	1.2
FM4743W	11.7	13.0	14.3	19.0	10.0	700	0.25	5.0	9.9	344.0	1.2
FM4743AW	12.35	13.0	13.65	19.0	10.0	700	0.25	5.0	9.9	344.0	1.2
FM4744W	13.5	15.0	16.5	17.0	14.0	700	0.25	5.0	11.4	305.0	1.2
FM4744AW	14.25	15.0	15.75	17.0	14.0	700	0.25	5.0	11.4	305.0	1.2
FM4745W	14.4	16.0	17.6	15.5	16.0	700	0.25	5.0	12.2	285.0	1.2
FM4745AW	15.2	16.0	16.8	15.5	16.0	700	0.25	5.0	12.2	285.0	1.2
FM4746W	16.2	18.0	19.8	14.0	20.0	750	0.25	5.0	13.7	250.0	1.2
FM4746AW	17.1	18.0	18.9	14.0	20.0	750	0.25	5.0	13.7	250.0	1.2
FM4747W	18.0	20.0	22.0	12.5	22.0	750	0.25	5.0	15.2	225.0	1.2
FM4747AW	19.0	20.0	21.0	12.5	22.0	750	0.25	5.0	15.2	225.0	1.2
FM4748W	19.8	22.0	24.2	11.5	23.0	750	0.25	5.0	16.7	205.0	1.2
FM4748AW	20.9	22.0	23.1	11.5	23.0	750	0.25	5.0	16.7	205.0	1.2
FM4749W	21.6	24.0	26.4	10.5	25.0	750	0.25	5.0	18.2	190.0	1.2
FM4749AW	22.8	24.0	25.2	10.5	25.0	750	0.25	5.0	18.2	190.0	1.2
FM4750W	24.3	27.0	29.7	9.5	35.0	750	0.25	5.0	20.6	170.0	1.2
FM4750AW	25.65	27.0	28.35	9.5	35.0	750	0.25	5.0	20.6	170.0	1.2
FM4751W	27.0	30.0	33.0	8.5	40.0	1000	0.25	5.0	22.8	150.0	1.2
FM4751AW	28.5	30.0	31.5	8.5	40.0	1000	0.25	5.0	22.8	150.0	1.2
FM4752W	29.7	33.0	36.3	7.5	45.0	1000	0.25	5.0	25.1	135.0	1.2
FM4752AW	31.35	33.0	34.65	7.5	45.0	1000	0.25	5.0	25.1	135.0	1.2
FM4753W	32.4	36.0	39.6	7.0	50.0	1000	0.25	5.0	27.4	125.0	1.2
FM4753AW	34.2	36.0	37.8	7.0	50.0	1000	0.25	5.0	27.4	125.0	1.2
FM4754W	35.1	39.0	42.9	6.5	60.0	1000	0.25	5.0	29.7	115.0	1.2
FM4754AW	37.05	39.0	40.95	6.5	60.0	1000	0.25	5.0	29.7	115.0	1.2
FM4755W	38.7	43.0	47.3	6.0	70.0	1500	0.25	5.0	32.7	110.0	1.2
FM4755AW	40.85	43.0	45.15	6.0	70.0	1500	0.25	5.0	32.7	110.0	1.2
FM4756W	42.3	47.0	51.7	5.5	80.0	1500	0.25	5.0	35.8	95.0	1.2
FM4756AW	44.65	47.0	49.35	5.5	80.0	1500	0.25	5.0	35.8	95.0	1.2
FM4757W	45.9	51.0	56.1	5.0	95.0	1500	0.25	5.0	38.8	90.0	1.2
FM4757AW	48.45	51.0	53.55	5.0	95.0	1500	0.25	5.0	38.8	90.0	1.2
FM4758W	50.4	56.0	61.6	4.5	110.0	2000	0.25	5.0	42.6	80.0	1.2
FM4758AW	53.2	56.0	58.8	4.5	110.0	2000	0.25	5.0	42.6	80.0	1.2
FM4759W	55.8	62.0	68.2	4.0	125.0	2000	0.25	5.0	47.1	70.0	1.2
FM4759AW	58.9	62.0	65.1	4.0	125.0	2000	0.25	5.0	47.1	70.0	1.2

ELECTRICAL CHARACTERISTICS (At T_A = 25°C unless otherwise noted)

TYPE	NOMINAL ZENER VOLTAGE			TEST CURRENT	MAXIMUM DYNAMIC IMPEDANCE			MAXIMUM DC REVERSE LEAKAGE CURRENT		MAXIMUM SURGE CURRENT	MAXIMUM FORWARD VOLTAGE
	VZ at IZT (NOTE 1) (Volts)				IZT (mA)	ZZT at IZT (ohms)	ZZK at IZK (ohms)	(NOTE 1) IZK (mA)	IR (μ A)		
	Min.	Typ.	Max.								
FM4756W	42.3	47.0	51.7	5.5	80.0	1500	0.25	5.0	35.8	95.0	1.2
FM4756AW	44.65	47.0	49.35	5.5	80.0	1500	0.25	5.0	35.8	95.0	1.2
FM4757W	45.9	51.0	56.1	5.0	95.0	1500	0.25	5.0	38.8	90.0	1.2
FM4757AW	48.45	51.0	53.55	5.0	95.0	1500	0.25	5.0	38.8	90.0	1.2
FM4758W	50.4	56.0	61.6	4.5	110.0	2000	0.25	5.0	42.6	80.0	1.2
FM4758AW	53.2	56.0	58.8	4.5	110.0	2000	0.25	5.0	42.6	80.0	1.2
FM4759W	55.8	62.0	68.2	4.0	125.0	2000	0.25	5.0	47.1	70.0	1.2
FM4759AW	58.9	62.0	65.1	4.0	125.0	2000	0.25	5.0	47.1	70.0	1.2
FM4760W	61.2	68.0	74.8	3.7	150.0	2000	0.25	5.0	51.7	65.0	1.2
FM4760AW	67.66	68.0	68.34	3.7	150.0	2000	0.25	5.0	51.7	65.0	1.2
FM4761W	67.5	75.0	82.5	3.3	175.0	2000	0.25	5.0	56.0	60.0	1.2
FM4761AW	71.25	75.0	78.75	3.3	175.0	2000	0.25	5.0	56.0	60.0	1.2
FM4762W	73.8	82.0	90.2	3.0	200.0	3000	0.25	5.0	62.2	55.0	1.2
FM4762AW	77.9	82.0	86.1	3.0	200.0	3000	0.25	5.0	62.2	55.0	1.2
FM4763W	81.9	91.0	100.1	2.0	250.0	3000	0.25	5.0	69.2	50.0	1.2
FM4763W	86.45	91.0	95.55	2.0	250.0	3000	0.25	5.0	69.2	50.0	1.2

Notes : 1. Standard V_Z Tolerance is 10% , Suffix " A " denotes 5% tolerance.

2007-10

2. Surge current is a non-repetitive, 8.3ms pulse width square wave or equivalent sine-wave superimposed on IZT per JEDEC Method.

3. Maximum steady state power dissipation is 1.0 watt at T_L = 75°C.

4. "Fully ROHS compliant", "100% Sn plating (Pb-free)".

RATING AND CHARACTERISTICS CURVES (FM4735(A)W THRU FM4763(A)W)

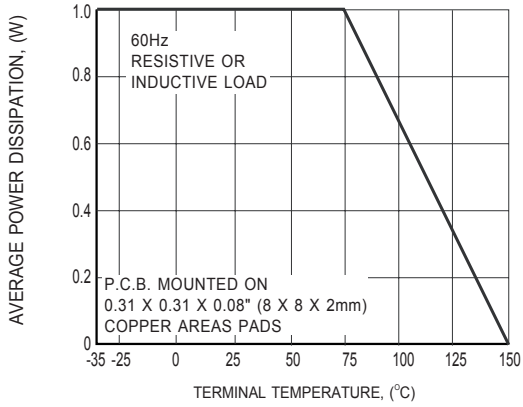

FIG.1 MAXIMUM CONTINUOUS POWER DISSIPATION

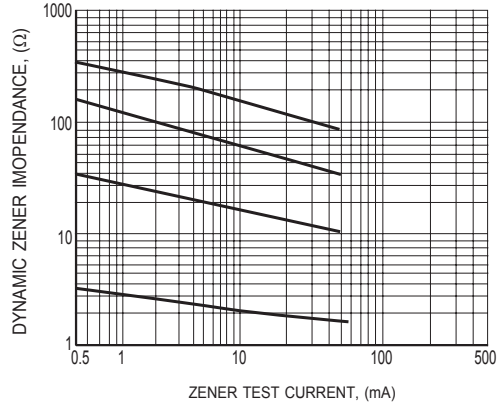

FIG.2 TYPICAL ZENER IMPEDANCE

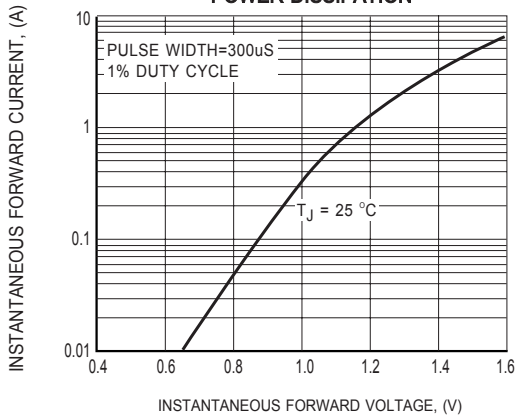

FIG.3 TYPICAL INSTANTANEOUS FORWARD CHARACTERISTICS FOR FM4763W

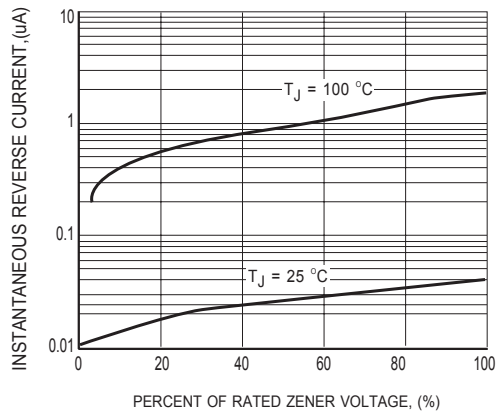

FIG.4 TYPICAL REVERSE CHARACTERISTICS

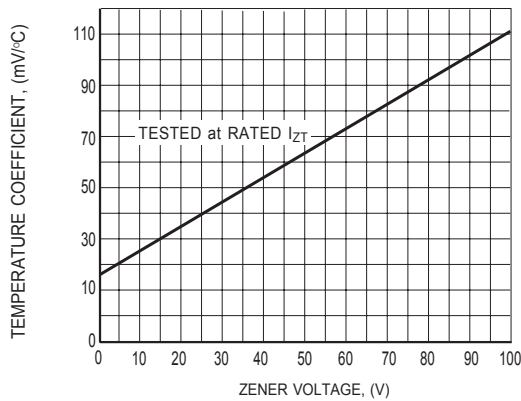

FIG.5 TYPICAL TEMPERATURE COEFFICIENTS

DISCLAIMER NOTICE

Rectron Inc reserves the right to make changes without notice to any product specification herein, to make corrections, modifications, enhancements or other changes. Rectron Inc or anyone on its behalf assumes no responsibility or liability for any errors or inaccuracies. Data sheet specifications and its information contained are intended to provide a product description only. "Typical" parameters which may be included on RECTRON data sheets and/ or specifications can and do vary in different applications and actual performance may vary over time. Rectron Inc does not assume any liability arising out of the application or use of any product or circuit.

Rectron products are not designed, intended or authorized for use in medical, life-saving implant or other applications intended for life-sustaining or other related applications where a failure or malfunction of component or circuitry may directly or indirectly cause injury or threaten a life without expressed written approval of Rectron Inc. Customers using or selling Rectron components for use in such applications do so at their own risk and shall agree to fully indemnify Rectron Inc and its subsidiaries harmless against all claims, damages and expenditures.