

## Features

- **Ultra Low-power consumption**
  - Active: 40mA at 35ns
  - Stand-by: 10  $\mu$ A (CMOS input/output)  
2  $\mu$ A CMOS input/output, L version
- **Single + 2.7V to 3.3V Power Supply**
- **Equal access and cycle time**
- **35/45/55/70/85/100 ns access time**
- **Easy memory expansion with  $\overline{CE1}$ , CE2 and  $\overline{OE}$  inputs**
- **1.0V data retention mode**
- **TTL compatible, Tri-state input/output**
- **Automatic power-down when deselected**
- **Package available: 32-TSOP1 / STSOP**
- **48 Ball CSP\_BGA**

## Functional Description

The V62C3802096L is a low power CMOS Static RAM organized as 262,144 words by 8 bits. Easy memory expansion is provided by an active LOW  $\overline{CE1}$ , an active HIGH CE2, an active LOW  $\overline{OE}$ , and Tri-state I/O's. This device has an automatic power-down mode feature when deselected.

Writing to the device is accomplished by taking Chip Enable 1 ( $\overline{CE1}$ ) with Write Enable ( $\overline{WE}$ ) LOW, and Chip Enable 2 (CE2) HIGH. Reading from the device is performed by taking Chip Enable 1 ( $\overline{CE1}$ ) with Output Enable ( $\overline{OE}$ ) LOW while Write Enable ( $\overline{WE}$ ) and Chip Enable 2 (CE2) is HIGH. The I/O pins are placed in a high-impedance state when the device is deselected: the outputs are disabled during a write cycle.

The V62C3802096LL comes with a 1V data retention feature and Lower Standby Power. The V62C3802096L is available in a 32-pin 8 x 20 mm TSOP1/8 x 13.4mm STSOP and CSP type 48-fpBGA packages.

## Logic Block Diagram

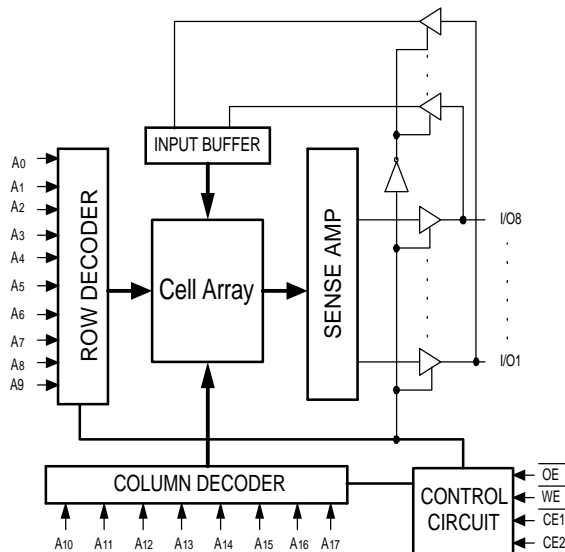

## 32-Pin TSOP1 / STSOP(CSP\_BGA see next page)

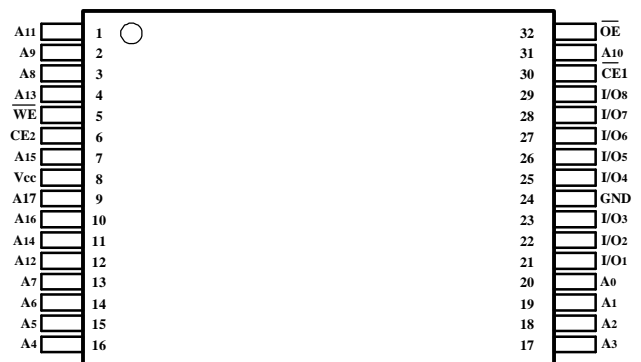

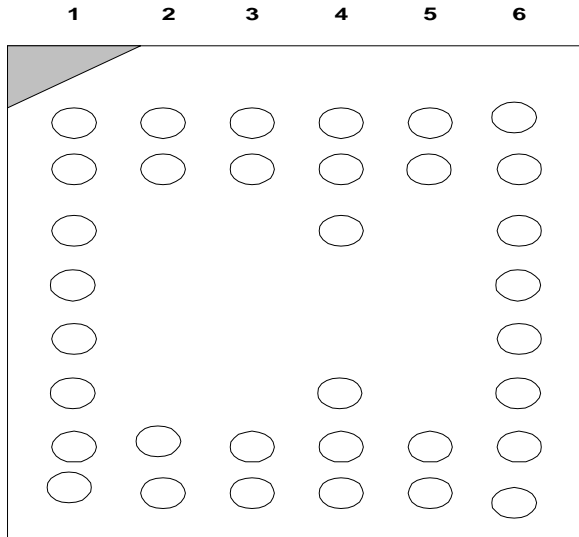
**MOSEL VITELIC V62C3802096L(L)B**

Top View

	1	2	3	4	5	6
A	A0	A1	CS2	A3	A6	A8
B	I/O5	A2	$\overline{\text{WE}}$	A4	A7	I/O1
C	I/O6	NC	NC	A5	NC	I/O2
D	VSS	NC	NC	NC	NC	VCC
E	VCC	NC	NC	NC	NC	VSS
F	I/O7	NC	NC	A17	NC	I/O3
G	I/O8	$\overline{\text{OE}}$	$\overline{\text{CS1}}$	A16	A15	I/O4
H	A9	A10	A11	A12	A13	A14

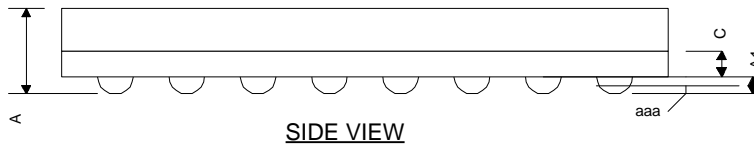
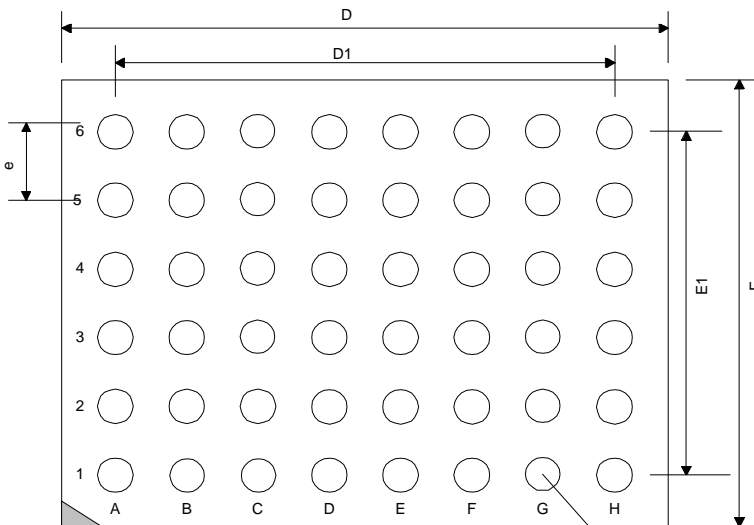
Note: NC means no Ball.

Top View
**48 Ball - 9x12 fpBGA (Ultra Low Power)**
**PACKAGE OUTLINE DWG.**

SIDE VIEW

BOTTOM VIEW
**b**  
SOLDER BALL

SYMBOL	UNIT:MM
A	1.05+0.15
A1	0.25±0.05
b	0.35±.05
c	0.30(TYP)
D	12.00±0.10
D1	5.25
E	9.00±0.10
E1	3.75
e	0.75TYP
aaa	0.10

**Absolute Maximum Ratings \***

Parameter	Symbol	Minimum	Maximum	Unit
Voltage on Any Pin Relative to Gnd	Vt	-0.5	4.6	V
Power Dissipation	P <sub>T</sub>	–	1.0	W
Storage Temperature (Plastic)	Tstg	-55	+150	°C
Temperature Under Bias	Tbias	-40	+85	°C

\* **Note:** Stresses greater than those listed above Absolute Maximum Ratings may cause permanent damage to the device. This is a stress rating only and functional operation of the device at these or any conditions outside those indicated in the operational sections of this specification is not implied. Exposure to Absolute Maximum Rating conditions for extended periods may affect reliability.

**Truth Table**

$\overline{\text{CE1}}$	$\text{CE2}$	$\overline{\text{WE}}$	$\overline{\text{OE}}$	Data	Mode
H	X	X	X	High-Z	Standby
X	L	X	X	High-Z	Standby
L	H	H	L	Data Out	Active, Read
L	H	H	H	High-Z	Active, Output Disable
L	H	L	X	Data In	Active, Write

\* **Key:** X = Don't Care, L = Low, H = High

**Recommended Operating Conditions (T<sub>A</sub> = 0°C to +70°C / -40°C to 85°C\*\*)**

Parameter	Symbol	Min	Typ	Max	Unit
Supply Voltage	V <sub>CC</sub>	2.7	3.0	3.3	V
	Gnd	0.0	0.0	0.0	V
Input Voltage	V <sub>IH</sub>	2.2	-	V <sub>CC</sub> + 0.2	V
	V <sub>IL</sub>	-0.5*	-	0.6	V

\* V<sub>IL</sub> min = -2.0V for pulse width less than t<sub>RC</sub>/2.

\*\* For Industrial Temperature.

**DC Operating Characteristics** ( $V_{CC} = 2.7$  to  $3.3V$ ,  $Gnd = 0V$ ,  $T_A = 0^{\circ}C$  to  $+70^{\circ}C$  /  $-40^{\circ}C$  to  $85^{\circ}C$ )

Parameter	Sym	Test Conditions	-55		-70		-85		-100		Unit	
			Min	Max	Min	Max	Min	Max	Min	Max		
Input Leakage Current	$I_{LI}$	$V_{CC} = Max,$ $V_{in} = Gnd$ to $V_{CC}$	-	1	-	1	-	1	-	1	$\mu A$	
Output Leakage Current	$I_{LO}$	$\overline{CE1} = V_{IH}$ or $CE2 = V_{IL}$ $V_{CC} = Max, V_{OUT} = Gnd$ to $V_{CC}$	-	1	-	1	-	1	-	1	$\mu A$	
Operating Power Supply Current	$I_{CC}$	$\overline{CE1} = V_{IL}, CE2 = V_{IH}$ $V_{IN} = V_{IH}$ or $V_{IL}, I_{OUT} = 0mA$	-	3	-	3	-	3	-	3	$mA$	
Average Operating Current	$I_{CC1}$	$\overline{CE1} = V_{IL}, CE2 = V_{IH}$ $I_{OUT} = 0mA,$ Min Cycle, 100% Duty	-	35	-	35	-	30	-	25	$mA$	
	$I_{CC2}$	$\overline{CE1} = 0.2V,$ $CE2 = V_{CC} - 0.2V$ $I_{OUT} = 0mA,$ Cycle Time = $1\mu s$ , 100% Duty	-	3	-	3	-	3	-	3	$mA$	
Standby Power Supply Current (TTL Level)	$I_{SB}$	$\overline{CE1} = V_{IH}$ or $CE2 = V_{IL}$	-	0.5	-	0.5	-	0.5	-	0.5	$mA$	
Standby Power Supply Current (CMOS Level)	$I_{SB1}$	$\overline{CE1} \geq V_{CC} - 0.2V$ or $CE2 \leq 0.2V, f = 0$ $V_{IN} \leq 0.2V$ or $V_{IN} \geq V_{CC} - 0.2V$	L	-	10	-	10	-	10	-	10	$\mu A$
			LL	-	2	-	2	-	2	-	2	$\mu A$
Output Low Voltage	$V_{OL}$	$I_{OL} = 2 mA$	-	0.4	-	0.4	-	0.4	-	0.4	V	
Output High Voltage	$V_{OH}$	$I_{OH} = -2 mA$	2.4	-	2.4	-	2.4	-	2.4	-	V	

**Capacitance** ( $f = 1MHz, T_A = 25^{\circ}C$ )

Parameter*	Symbol	Test Condition	Max	Unit
Input Capacitance	$C_{in}$	$V_{in} = 0V$	7	pF
I/O Capacitance	$C_{I/O}$	$V_{in} = V_{out} = 0V$	8	pF

\* This parameter is guaranteed by device characterization and is not production tested.

**AC Test Conditions**

Input Pulse Level                    0.6V to 2.2V  
 Input Rise and Fall Time            5ns  
 Input and Output Timing  
 Reference Level                        50% of input level  
     ( $V_{IL} + V_{IH}$ )/2

**Output Load Condition**

70ns/85 ns                             $C_L = 30pf + 1TTL$  Load  
 Load 100ns/120 ns                 $C_L = 100pf + 1TTL$  Load

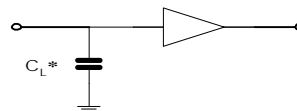

Figure A. \* Including Scope and Jig Capacitance

**DC Operating Characteristics** ( $V_{CC} = 2.7$  to  $3.3V$ ,  $Gnd = 0V$ ,  $T_A = 0^{\circ}C$  to  $+70^{\circ}C$  /  $-40^{\circ}C$  to  $85^{\circ}C$ )

Parameter	Sym	Test Conditions	-35		-45		Unit	
			Min	Max	Min	Max		
Input Leakage Current	$I_{LI}$	$V_{CC} = \text{Max},$ $V_{in} = \text{Gnd to } V_{CC}$	-	1	-	1	$\mu A$	
Output Leakage Current	$I_{LO}$	$\overline{CE1} = V_{IH}$ or $CE2 = V_{IL}$ $V_{CC} = \text{Max}, V_{OUT} = \text{Gnd to } V_{CC}$	-	1	-	1	$\mu A$	
Operating Power Supply Current	$I_{CC}$	$\overline{CE1} = V_{IL}, CE2 = V_{IH}$ $V_{IN} = V_{IH}$ or $V_{IL}, I_{OUT} = 0mA$	-	3	-	3	mA	
Average Operating Current	$I_{CC1}$	$\overline{CE1} = V_{IL}, CE2 = V_{IH}$ $I_{OUT} = 0mA,$ Min Cycle, 100% Duty	-	40	-	40	mA	
	$I_{CC2}$	$\overline{CE1} = 0.2V,$ $CE2 = V_{CC} - 0.2V$ $I_{OUT} = 0mA,$ Cycle Time=1 $\mu s$ , 100% Duty	-	3	-	3	mA	
Standby Power Supply Current (TTL Level)	$I_{SB}$	$\overline{CE1} = V_{IH}$ or $CE2 = V_{IL}$	-	0.5	-	0.5	mA	
Standby Power Supply Current (CMOS Level)	$I_{SB1}$	$\overline{CE1} \geq V_{CC} - 0.2V$ or $CE2 \leq 0.2V, f = 0$ $V_{IN} \leq 0.2V$ or $V_{IN} \geq V_{CC} - 0.2V$	L	-	10	-	10	$\mu A$
			LL	-	2	-	2	$\mu A$
Output Low Voltage	$V_{OL}$	$I_{OL} = 2 mA$	-	0.4	-	0.4	V	
Output High Voltage	$V_{OH}$	$I_{OH} = -2 mA$	2.4	-	2.4	-	V	

**Read Cycle** <sup>(3,9)</sup> ( $V_{CC} = 2.7$  to  $3.3V$ ,  $Gnd = 0V$ ,  $T_A = 0^{\circ}C$  to  $+70^{\circ}C$  /  $-40^{\circ}C$  to  $+85^{\circ}C$ )

Parameter	Symbol	-55		-70		-85		-100		Unit	Note
		Min	Max	Min	Max	Min	Max	Min	Max		
Read Cycle Time	$t_{RC}$	55	-	70	-	85	-	100	-	ns	
Address Access Time	$t_{AA}$	-	55	-	70	-	85	-	100	ns	
Chip Enable Access Time	$t_{ACE}$	-	55	-	70	-	85	-	100	ns	
Output Enable Access Time	$t_{OE}$	-	40	-	40	-	40	-	50	ns	
Output Hold from Address Change	$t_{OH}$	10	-	10	-	10	-	10	-	ns	
Chip Enable to Output in Low-Z	$t_{CLZ}$	10	-	10	-	10	-	10	-	ns	4,5
Chip Disable to Output in High-Z	$t_{CHZ}$	-	25	-	30	-	35	-	40	ns	4,5
Output Enable to Output in Low-Z	$t_{OLZ}$	5	-	5	-	5	-	5	-	ns	4,5
Output Disable to Output in High-Z	$t_{OHZ}$	-	20	-	25	-	30	-	35	ns	4,5
Power-Up Time	$t_{PU}$	0	-	0	-	0	-	0	-	ns	5
Power-Down Time	$t_{PD}$	-	55	-	70	-	85	-	100	ns	5

**Write Cycle** <sup>(3,11)</sup> ( $V_{CC} = 2.7$  to  $3.3V$ ,  $Gnd = 0V$ ,  $T_A = 0^{\circ}C$  to  $+70^{\circ}C$  /  $-40^{\circ}C$  to  $+85^{\circ}C$ )

Parameter	Symbol	-55		-70		-85		-100		Unit	Note
		Min	Max	Min	Max	Min	Max	Min	Max		
Write Cycle Time	$t_{WC}$	55	-	70	-	85	-	100	-	ns	
Chip Enable to Write End	$t_{CW}$	40	-	60	-	70	-	80	-	ns	
Address Setup to Write End	$t_{AW}$	40	-	60	-	70	-	80	-	ns	
Address Setup Time	$t_{AS}$	0	-	0	-	0	-	0	-	ns	
Write Pulse Width	$t_{WP}$	40	-	50	-	60	-	70	-	ns	
Write Recovering Time	$t_{WR}$	0	-	0	-	0	-	0	-	ns	
Data Valid to Write End	$t_{DW}$	25	-	30	-	35	-	40	-	ns	
Data Hold Time	$t_{DH}$	0	-	0	-	0	-	0	-	ns	
Write Enable to Output in High-Z	$t_{WZ}$	-	25	-	30	-	35	-	40	ns	4,5
Output Active from Write End	$t_{OW}$	5	-	5	-	5	-	5	-	ns	4,5

**Read Cycle** <sup>(3,9)</sup> ( $V_{CC} = 2.7$  to  $3.3V$ ,  $Gnd = 0V$ ,  $T_A = 0^{\circ}C$  to  $+70^{\circ}C$  /  $-40^{\circ}C$  to  $+85^{\circ}C$ )

Parameter	Symbol	-35		-45		Unit	Note
		Min	Max	Min	Max		
Read Cycle Time	$t_{RC}$	35	-	45	-	ns	
Address Access Time	$t_{AA}$	-	35	-	45	ns	
Chip Enable Access Time	$t_{ACE}$	-	35	-	45	ns	
Output Enable Access Time	$t_{OE}$	-	20	-	20	ns	
Output Hold from Address Change	$t_{OH}$	5	-	5	-	ns	
Chip Enable to Output in Low-Z	$t_{CLZ}$	5	-	5	-	ns	4,5
Chip Disable to Output in High-Z	$t_{CHZ}$	-	20	-	25	ns	4,5
Output Enable to Output in Low-Z	$t_{OLZ}$	5	-	5	-	ns	4,5
Output Disable to Output in High-Z	$t_{OHZ}$	-	15	-	20	ns	4,5
Power-Up Time	$t_{PU}$	0	-	0	-	ns	5
Power-Down Time	$t_{PD}$	-	35	-	45	ns	5

**Write Cycle** <sup>(3,11)</sup> ( $V_{CC} = 2.7$  to  $3.3V$ ,  $Gnd = 0V$ ,  $T_A = 0^{\circ}C$  to  $+70^{\circ}C$  /  $-40^{\circ}C$  to  $+85^{\circ}C$ )

Parameter	Symbol	-35		-45		Unit	Note
		Min	Max	Min	Max		
Write Cycle Time	$t_{WC}$	35	-	45	-	ns	
Chip Enable to Write End	$t_{CW}$	30	-	40	-	ns	
Address Setup to Write End	$t_{AW}$	30	-	40	-	ns	
Address Setup Time	$t_{AS}$	0	-	0	-	ns	
Write Pulse Width	$t_{WP}$	30	-	35	-	ns	
Write Recovering Time	$t_{WR}$	0	-	0	-	ns	
Data Valid to Write End	$t_{DW}$	20	-	25	-	ns	
Data Hold Time	$t_{DH}$	0	-	0	-	ns	
Write Enable to Output in High-Z	$t_{WZ}$	-	20	-	25	ns	4,5
Output Active from Write End	$t_{OW}$	5	-	5	-	ns	4,5

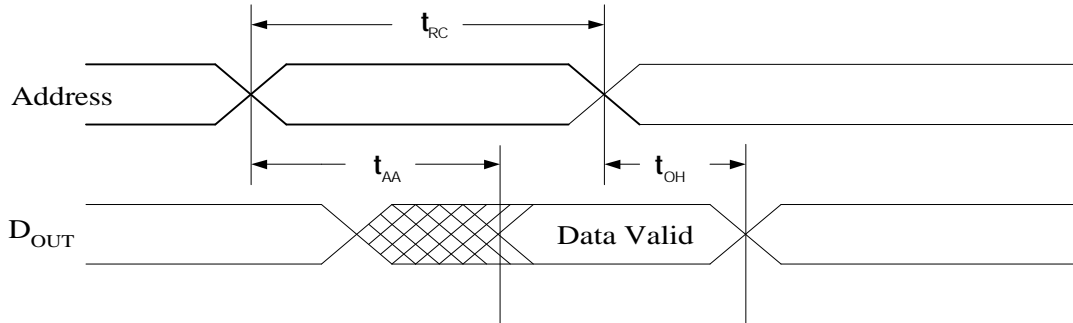
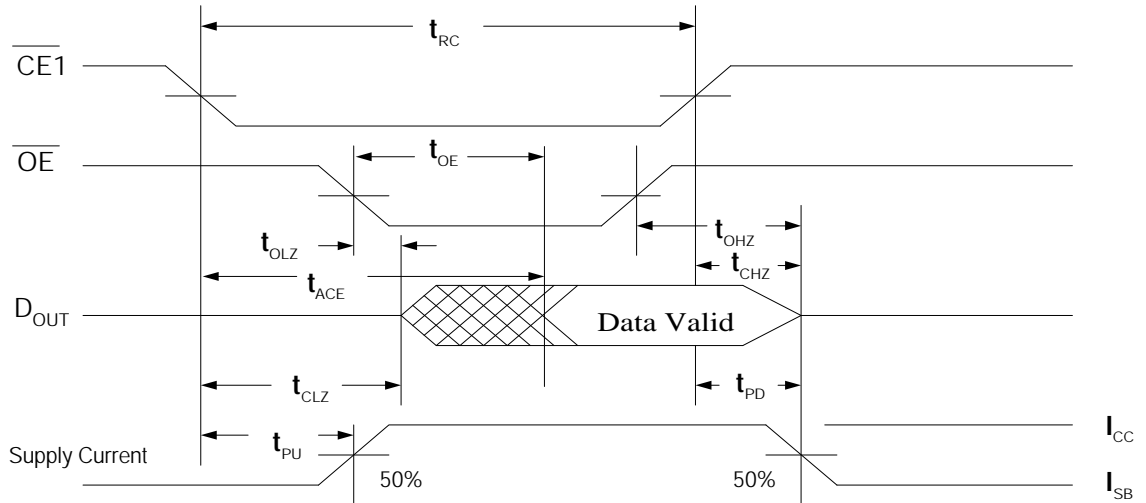
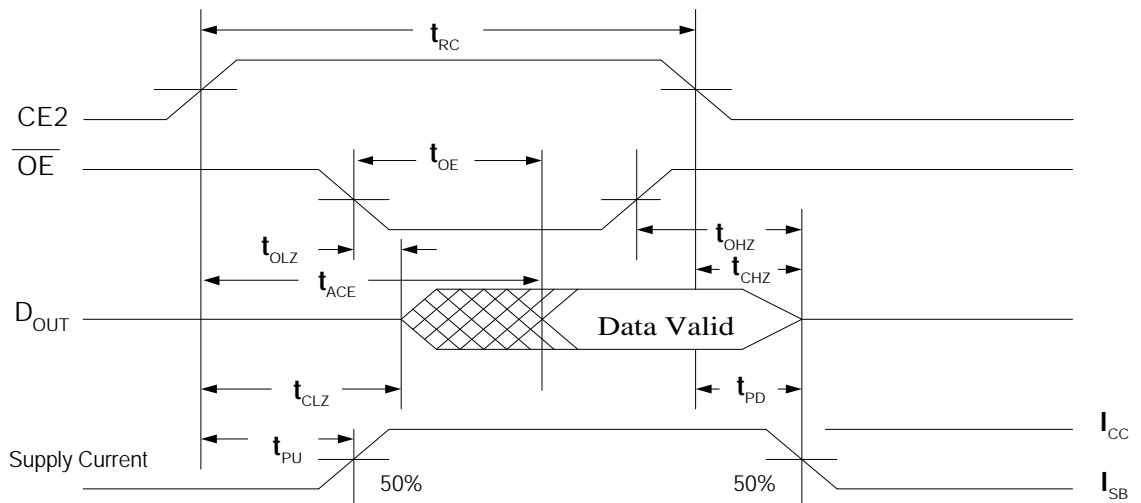
**Timing Waveform of Read Cycle 1** <sup>(3,6,7,9)</sup> (Address Controlled)

**Timing Waveform of Read Cycle 2** <sup>(5,6,8,9)</sup> ( $\overline{\text{CE1}}$  Controlled)

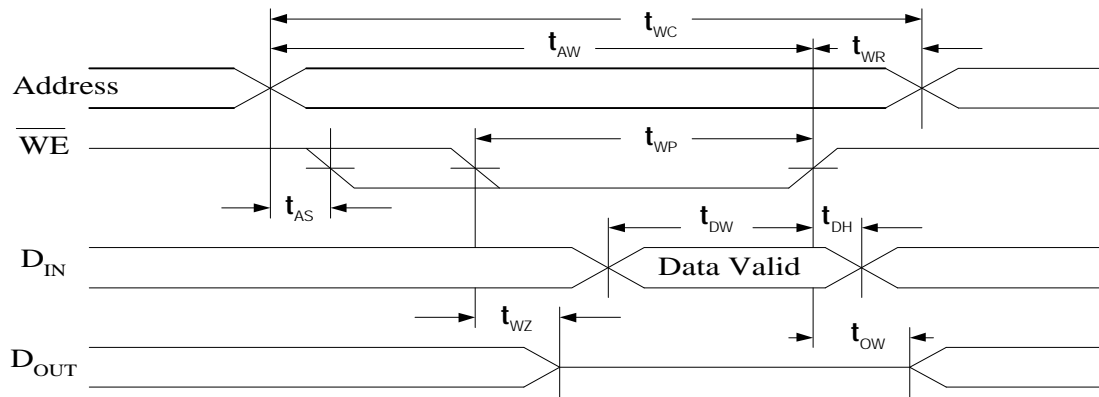
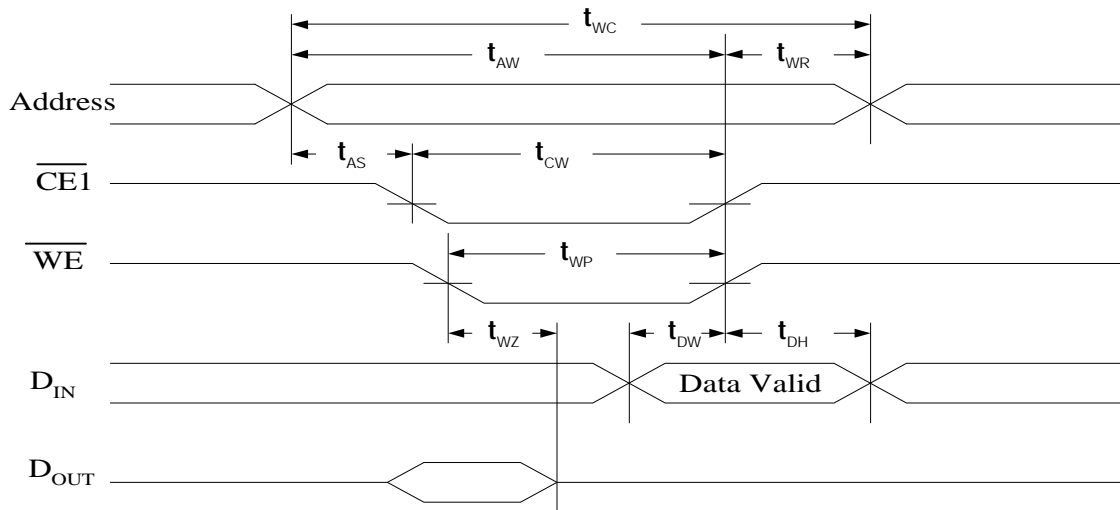
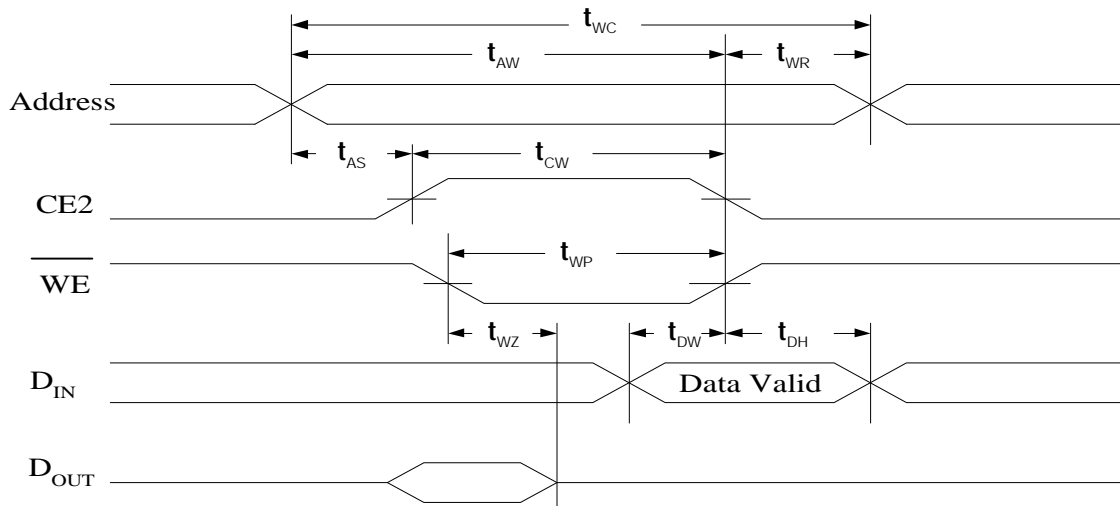
**Timing Waveform of Read Cycle 3** <sup>(3,6,8,9)</sup> (CE2 Controlled)

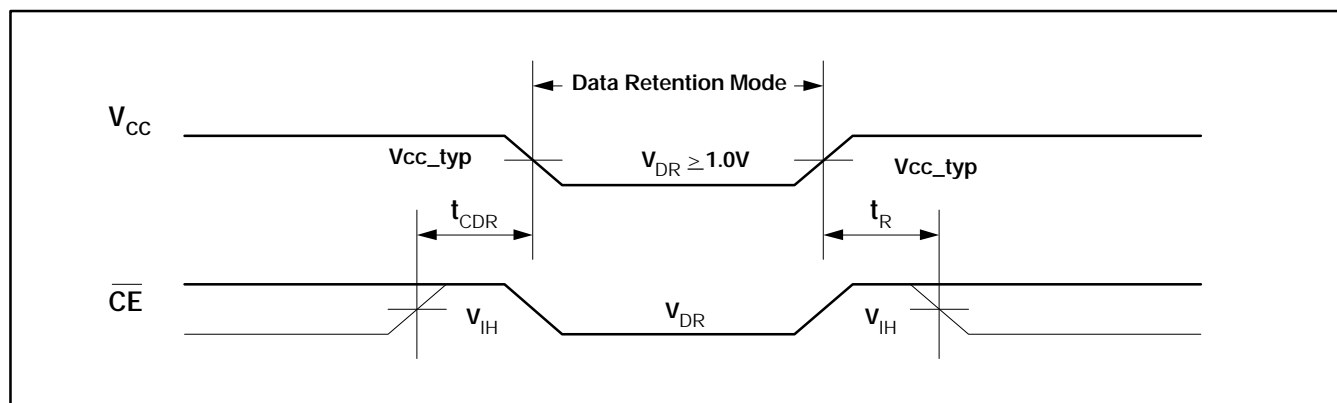

**Timing Waveform of Write Cycle 1 <sup>(10,11)</sup> ( $\overline{WE}$  Controlled)**

**Timing Waveform of Write Cycle 2 <sup>(10,11)</sup> ( $\overline{CE1}$  Controlled)**

**Timing Waveform of Write Cycle 3 <sup>(10,11)</sup> ( $\overline{CE2}$  Controlled)**

**Data Retention Characteristics (L Version Only)<sup>(1)</sup>**

Parameter	Symbol	Test Condition	Min	Max	Unit
V <sub>CC</sub> for Data Retention	V <sub>DR</sub>	$\overline{CE}_1 \geq V_{CC} - 0.2V$ or	1.0	-	V
Data Retention Current	I <sub>CCDR</sub>	$CE_2 \leq +0.2V$	-	1	$\mu A$
Chip Deselect to Data Retention Time	t <sub>CDR</sub>	$V_{IN} \geq V_{CC} - 0.2V$ or	0	-	ns
Operation Recovery Time <sup>(2)</sup>	t <sub>R</sub>	$V_{IN} \leq 0.2V$	t <sub>RC</sub>	-	ns

**Data Retention Waveform (L Version Only) (T<sub>A</sub> = 0<sup>0</sup>C to +70<sup>0</sup>C / -40<sup>0</sup>C to +85<sup>0</sup>C)**

**Notes**

1. L-version includes this feature.
2. This Parameter is sampled and not 100% tested.
3. For test conditions, see *AC Test Condition*, Figure A.
4. This parameter is tested with CL = 5pF as shown in Figure B. Transition is measured ± 500mV from steady-state voltage.
5. This parameter is guaranteed, but is not tested.
6.  $\overline{WE}$  is HIGH for read cycle.
7.  $\overline{CE}_1$  and  $\overline{OE}$  are LOW and CE2 is HIGH for read cycle.
8. Address valid prior to or coincident with  $\overline{CE}_1$  transition LOW or CE2 transition HIGH.
9. All read cycle timings are referenced from the last valid address to the first transition address.
10.  $\overline{CE}_1$  or  $\overline{WE}$  must be HIGH or CE2 must be LOW during address transition.
11. All write cycle timings are referenced from the last valid address to the first transition address.

---

**Ordering Information**

<b>Device Type*</b>	<b>Speed</b>	<b>Package</b>
V62C3802096L-35V	35 ns	8x13.4 mm 32-pin Plastic STSOP
V62C3802096L-45V	45 ns	
V62C3802096L-55V	55 ns	
V62C3802096L-70V	70 ns	
V62C3802096L-85V	85 ns	
V62C3802096L-100V	100 ns	
V62C3802096LL-35V	35 ns	
V62C3802096LL-45V	45 ns	
V62C3802096LL-55V	55 ns	
V62C3802096LL-70V	70 ns	
V62C3802096LL-85V	85 ns	
V62C3802096LL-100V	100 ns	
V62C3802096L-35T	35 ns	8 x 20 mm 32-pin Plastic TSOP1
V62C3802096L-45T	45 ns	
V62C3802096L-55T	55 ns	
V62C3802096L-70T	70 ns	
V62C3802096L-85T	85 ns	
V62C3802096L-100T	100 ns	
V62C3802096LL-35T	35 ns	
V62C3802096LL-45T	45 ns	
V62C3802096LL-55T	55 ns	
V62C3802096LL-70T	70 ns	
V62C3802096LL-85T	85 ns	
V62C3802096LL-100T	100 ns	
V62C3802096L(L)-35B	35 ns	CSP type 48-fpBGA
V62C3802096L(L)-45B	45 ns	
V62C3802096L(L)-55B	55 ns	
V62C3802096L(L)-70B	70 ns	
V62C3802096L(L)-85B	85 ns	
V62C3802096L(L)-100B	100 ns	

\* For Industrial Temperature tested devices, an "I" designator will be added to the end of the device number.

**U.S.A.**

3910 NORTH FIRST STREET  
SAN JOSE, CA 95134  
PHONE: 408-433-6000  
FAX: 408-433-0952

**TAIWAN**

7F, NO. 102  
MIN-CHUAN E. ROAD, SEC. 3  
TAIPEI  
PHONE: 886-2-2545-1213  
FAX: 886-2-2545-1209

**SINGAPORE**

10 ANSON ROAD #23-13  
INTERNATIONAL PLAZA  
SINGAPORE 079903  
PHONE: 65-3231801  
FAX: 65-3237013

**UK & IRELAND**

SUITE 50, GROVEWOOD  
BUSINESS CENTRE  
STRATHCLYDE BUSINESS  
PARK  
BELLSHILL, LANARKSHIRE,  
SCOTLAND, ML4 3NQ  
PHONE: 44-1698-748515  
FAX: 44-1698-748516

NO 19 LI HSIN ROAD  
SCIENCE BASED IND. PARK  
HSIN CHU, TAIWAN, R.O.C.  
PHONE: 886-3-579-5888  
FAX: 886-3-566-5888

**JAPAN**

ONZE 1852 BUILDING 6F  
2-14-6 SHINTOMI, CHUO-KU  
TOKYO 104-0041  
PHONE: 03-3537-1400  
FAX: 03-3537-1402

**GERMANY  
(CONTINENTAL  
EUROPE & ISRAEL)**

BENZSTRASSE 32  
71083 HERRENBERG  
GERMANY  
PHONE: +49 7032 2796-0  
FAX: +49 7032 2796 22

**U.S. SALES OFFICES****NORTHWESTERN**

3910 NORTH FIRST STREET  
SAN JOSE, CA 95134  
PHONE: 408-433-6000  
FAX: 408-433-0952

**SOUTHWESTERN**

302 N. EL CAMINO REAL #200  
SAN CLEMENTE, CA 92672  
PHONE: 949-361-7873  
FAX: 949-361-7807

**CENTRAL,  
NORTHEASTERN &  
SOUTHEASTERN**

604 FIELDWOOD CIRCLE  
RICHARDSON, TX 75081  
PHONE: 214-826-6176  
FAX: 214-828-9754

---

The information in this document is subject to change without notice.

MOSEL VITELIC makes no commitment to update or keep current the information contained in this document. No part of this document may be copied or reproduced in any form or by any means without the prior written consent of MOSEL-VITELIC.

MOSEL VITELIC subjects its products to normal quality control sampling techniques which are intended to provide an assurance of high quality products suitable for usual commercial applications. MOSEL VITELIC does not do testing appropriate to provide 100% product quality assurance and does not assume any liability for consequential or incidental arising from any use of its products. If such products are to be used in applications in which personal injury might occur from failure, purchaser must do its own quality assurance testing appropriate to such applications.