

■ General Description

The AME1117 is a 1A low-dropout positive voltage regulator. It is available in fixed and adjustable output voltage versions. Overcurrent and thermal protection are integrated onto the chip. Output current will limit as while it reaches the pre-set current or temperature limit. The dropout voltage is specified at 1.45V Maximum at full rated output current. The AME1117 series provides excellent regulation over line, load and temperature variations.

■ Features

- Low Dropout Voltage ----- 1.45V at 1A
- Adjustable or Fixed Voltages:
1.8V, 2.5V, 3.3V, 5.0V
- Adjust Pin Current Less than 120 μ A
- Overcurrent Protection
- Thermal Protection
- Available in TO-220, TO-252, SOT-223
- All AME's Lead Free Products Meet RoHS Standards

■ Applications

- High Efficiency Linear Regulators
- Post Regulators for Switching Supplies
- 5V to 3.3V Voltage Converter
- Battery Charger

■ Functional Block Diagram

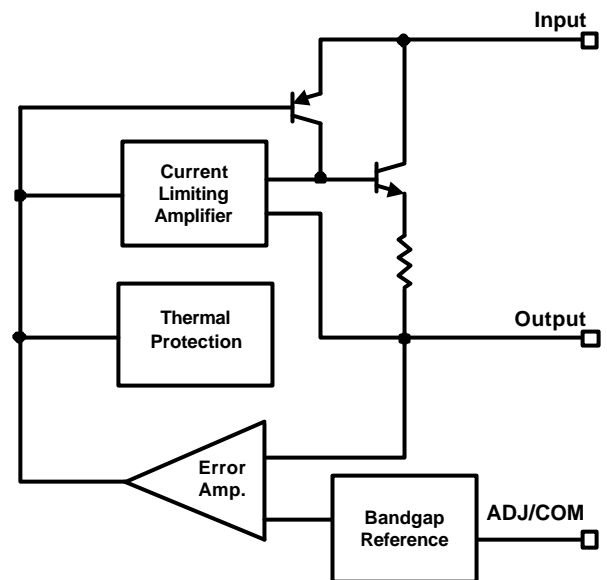

■ Typical Application

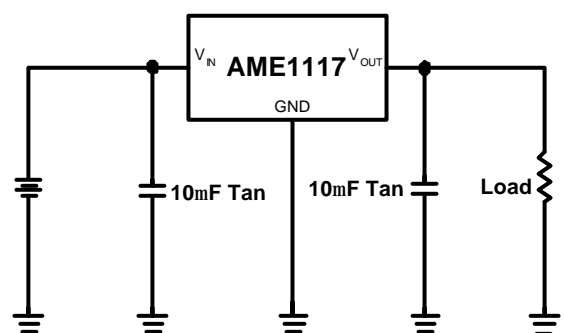



■ Pin Configuration

TO-220-3
Front View

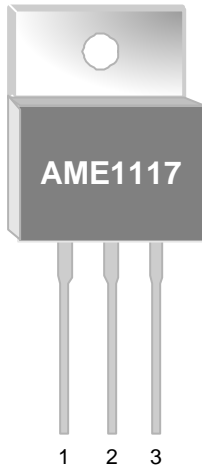

- AME1117**
1. ADJ / GND
 2. OUT (TAB)
 3. IN

* Die Attach:
Conductive Epoxy

SOT-223
Front View

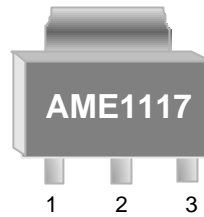

- AME1117**
1. ADJ / GND
 2. OUT (TAB)
 3. IN

* Die Attach:
Conductive Epoxy

TO-252-2
Front View

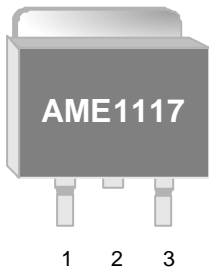

- AME1117**
1. ADJ / GND
 2. OUT (TAB)
 3. IN

* Die Attach:
Conductive Epoxy



■ Ordering Information

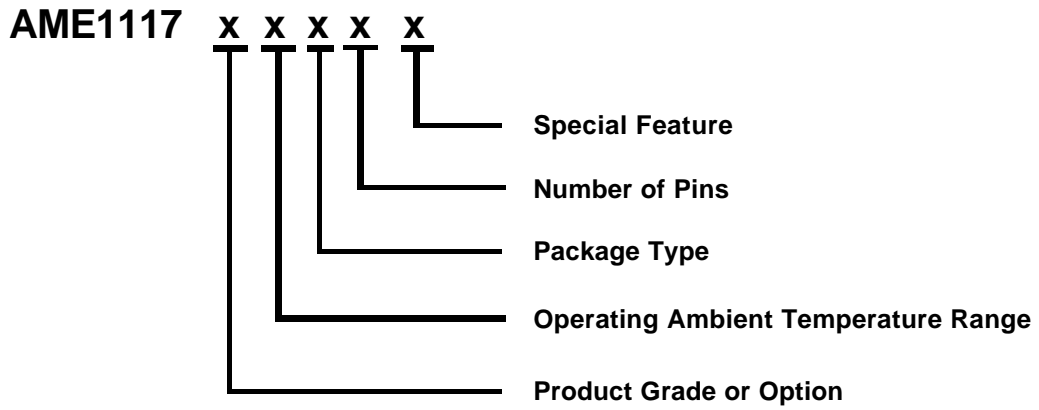

Product Grade or Option	Operating Ambient Temperature Range	Package Type	Number of Pins	Special Feature
A: ADJ B: 2.5V C: 3.3V D: 5.0V E: 1.8V	C: 0°C to 70°C	B: TO-220 C: TO-252 G: SOT-223	T: 3	Z: Lead Free



AME1117

■ Ordering Information (contd.)

Part Number	Marking*	Output Voltage	Package	Operating Ambient Temperature Range
AME1117ACGT	ABEyyww	ADJ	SOT-223	0°C to 70°C
AME1117ACGTZ	ABEyyww	ADJ	SOT-223	0°C to 70°C
AME1117BCGT	AKEyyww	2.5	SOT-223	0°C to 70°C
AME1117BCGTZ	AKEyyww	2.5	SOT-223	0°C to 70°C
AME1117CCGT	ABFyyww	3.3	SOT-223	0°C to 70°C
AME1117CCGTZ	ABFyyww	3.3	SOT-223	0°C to 70°C
AME1117DCGT	AKFyyww	5.0	SOT-223	0°C to 70°C
AME1117DCGTZ	AKFyyww	5.0	SOT-223	0°C to 70°C
AME1117ECGT	AXHyww	1.8	SOT-223	0°C to 70°C
AME1117ECGTZ	AXHyww	1.8	SOT-223	0°C to 70°C
AME1117ACCT	AME1117 ACCT yyww	ADJ	TO-252-2	0°C to 70°C
AME1117ACCTZ	AME1117 ACCT yyww	ADJ	TO-252-2	0°C to 70°C
AME1117BCCT	AME1117 BCCT yyww	2.5	TO-252-2	0°C to 70°C
AME1117BCCTZ	AME1117 BCCT yyww	2.5	TO-252-2	0°C to 70°C
AME1117CCCT	AME1117 CCCT yyww	3.3	TO-252-2	0°C to 70°C
AME1117CCCTZ	AME1117 CCCT yyww	3.3	TO-252-2	0°C to 70°C

Note: yyww & yww represent the date code

* A line on top of the first letter represents lead free plating such as $\overline{\text{A}}$ ME1117.

Please consult AME sales office or authorized Rep./Distributor for the availability of output voltage and package type.

■ Ordering Information

Part Number	Marking*	Output Voltage	Package	Operating Ambient Temperature Range
AME1117DCCT	AME1117 DCCT yyww	5.0	TO-252-2	0°C to 70°C
AME1117DCCTZ	AME1117 DCCT yyww	5.0	TO-252-2	0°C to 70°C
AME1117ECCT	AME1117 ECCT yyww	1.8	TO-252-2	0°C to 70°C
AME1117ECCTZ	AME1117 ECCT yyww	1.8	TO-252-2	0°C to 70°C
AME1117ACBT	AME1117 ACBT yyww	ADJ	TO-220	0°C to 70°C
AME1117ACBTZ	AME1117 ACBT yyww	ADJ	TO-220	0°C to 70°C
AME1117BCBT	AME1117 BCBT yyww	2.5	TO-220	0°C to 70°C
AME1117BCBTZ	AME1117 BCBT yyww	2.5	TO-220	0°C to 70°C
AME1117CCBT	AME1117 CCBT yyww	3.3	TO-220	0°C to 70°C
AME1117CCBTZ	AME1117 CCBT yyww	3.3	TO-220	0°C to 70°C
AME1117DCBT	AME1117 DCBT yyww	5.0	TO-220	0°C to 70°C
AME1117DCBTZ	AME1117 DCBT yyww	5.0	TO-220	0°C to 70°C
AME1117ECBT	AME1117 ECBT yyww	1.8	TO-220	0°C to 70°C
AME1117ECBTZ	AME1117 ECBT yyww	1.8	TO-220	0°C to 70°C



■ Absolute Maximum Ratings

Parameter	Package	Die Attach	Symbol	Maximum	Unit
Thermal Resistance* (Junction to Case)	TO-220-3	Conductive Epoxy	θ_{JC}	6	$^{\circ}\text{C}/\text{W}$
	TO-252-2			5	
	SOT-223			25	
Thermal Resistance (Junction to Ambient)	TO-220-3	Conductive Epoxy	θ_{JA}	55	$^{\circ}\text{C}/\text{W}$
	TO-252-2			90	
	SOT-223			120	
Internal Power Dissipation	TO-220-3	Conductive Epoxy	P_D	2200	mW
	TO-252-2			1200	
	SOT-223			900	
Input Voltage			V_{IN}	18	V
Operating Junction Temperature Range			T_J	0 to 125	$^{\circ}\text{C}$
Storage Temperature Range			T_{STG}	-65 to 150	$^{\circ}\text{C}$
Solder Iron (10 Sec)**				350	$^{\circ}\text{C}$

Caution: Stress above the listed absolute maximum rating may cause permanent damage to the device.

* Measure θ_{JC} on backside center of tab.

** MIL-STD-202G 210F

■ Electrical Specifications
AME1117Exxx

Parameter	Symbol	Test Condition	Min	Typ	Max	Units	
Output Voltage	V_{OUT}	$V_{IN} = 5V, I_o = 0A$	$T_J = 25^\circ C$	1.782	1.800	1.818	V
			$T_J = 0^\circ C \text{ to } 70^\circ C$	1.764	1.800	1.836	
Line Regulation	REG_{LINE}	$V_{IN} = 4.75V \text{ to } 7V,$ $I_o = 0A$	$T_J = 0^\circ C \text{ to } 70^\circ C$	-	-	0.2	%
Load Regulation	REG_{LOAD}	$V_{IN} = 5V,$ $I_o = 0A \sim 1A$	$T_J = 0^\circ C \text{ to } 70^\circ C$	-	0.1	1.0	
Dropout Voltage	$V_{DROPOUT}$	$I_o = 1A,$ $\Delta V_o = \pm 1\%$	$T_J = 0^\circ C \text{ to } 70^\circ C$	-	1.2	1.45	V
Current Limit	I_S	$V_{IN} = 4.75V \text{ to } 7V$	$T_J = 0^\circ C \text{ to } 70^\circ C$	1.0	1.5	-	A
Quiescent Current	I_Q	$V_{IN} = 5V, I_o = 0A \text{ to } 1A$	$T_J = 0^\circ C \text{ to } 70^\circ C$	-	6.0	13	mA
Temp. Coefficient	T_C	$V_{IN} = 4.75V \text{ to } 7V, I_o = 0A \text{ to } 1A$		-	0.005	-	%/ $^\circ C$
Temperature Stability	T_S	$V_{IN} = 5V, I_o = 100mA$	$T_J = 0^\circ C \text{ to } 70^\circ C$	-	0.5	-	%
RMS Output Noise	V_N	$10Hz \leq f \leq 10KHz$	$T_J = 25^\circ C$	-	0.003	-	% V_o
Ripple Rejection Ratio	R_A	$V_{IN} = 5V, I_o = 1A$	$T_J = 0^\circ C \text{ to } 70^\circ C$	60	72	-	dB

AME1117Dxxx

Parameter	Symbol	Test Condition	Min	Typ	Max	Units	
Output Voltage	V_{OUT}	$V_{IN} = 7V, I_o = 0A$	$T_J = 25^\circ C$	4.950	5.000	5.050	V
			$T_J = 0^\circ C \text{ to } 70^\circ C$	4.900	5.000	5.100	
Line Regulation	REG_{LINE}	$V_{IN} = 7V \text{ to } 9V,$ $I_o = 0A$	$T_J = 0^\circ C \text{ to } 70^\circ C$	-	-	0.2	%
Load Regulation	REG_{LOAD}	$V_{IN} = 7V$ $I_o = 0A \sim 1A$	$T_J = 0^\circ C \text{ to } 70^\circ C$	-	0.1	1.0	
Dropout Voltage	$V_{DROPOUT}$	$I_o = 0A \text{ to } 1A,$ $\Delta V_o = \pm 1\%$	$T_J = 0^\circ C \text{ to } 70^\circ C$	-	1.2	1.45	V
Current Limit	I_S	$V_{IN} = 7V \text{ to } 10V$	$T_J = 0^\circ C \text{ to } 70^\circ C$	1.0	1.5	-	A
Quiescent Current	I_Q	$V_{IN} = 7V, I_o = 0A \text{ to } 1A$	$T_J = 0^\circ C \text{ to } 70^\circ C$	-	6.0	13	mA
Temp. Coefficient	T_C	$V_{IN} = 7V \text{ to } 10V, I_o = 0A \text{ to } 1A$		-	0.005	-	%/ $^\circ C$
Temperature Stability	T_S	$V_{IN} = 5V, I_o = 100mA$	$T_J = 0^\circ C \text{ to } 70^\circ C$	-	0.5	-	%
RMS Output Noise	V_N	$10Hz \leq f \leq 10KHz$	$T_J = 25^\circ C$	-	0.003	-	% V_o
Ripple Rejection Ratio	R_A	$V_{IN} = 5V, I_o = 1A$	$T_J = 0^\circ C \text{ to } 70^\circ C$	60	72	-	dB



AME1117

■ Electrical Specifications

AME1117Cxxx

Parameter	Symbol	Test Condition	Min	Typ	Max	Units	
Output Voltage	V _{OUT}	V _{IN} = 5V, I _O = 0A	T _J =25°C	3.270	3.300	3.330	V
			T _J =0°C to 70°C	3.234	3.300	3.366	
Line Regulation	REG _{LINE}	V _{IN} = 4.75V to 7V, I _O = 0A	T _J =0°C to 70°C	-	-	0.2	%
Load Regulation	REG _{LOAD}	V _{IN} = 5V I _O = 0A to 1A	T _J =0°C to 70°C	-	0.1	1.0	
Dropout Voltage	V _{DROPOUT}	I _O = 0A to 1A, ΔV _O = ±1%	T _J =0°C to 70°C	-	1.2	1.45	V
Current Limit	I _S	V _{IN} = 4.75V to 7V	T _J =0°C to 70°C	1.0	1.5	-	A
Quiescent Current	I _Q	V _{IN} = 5V, I _O = 0A to 1A	T _J =0°C to 70°C	-	6.0	13	mA
Temp. Coefficient	T _C	V _{IN} = 4.75V to 7V, I _O = 0A~1A		-	0.005	-	%/°C
Temperature Stability	T _S	V _{IN} = 5V, I _O = 100mA	T _J =0°C to 70°C	-	0.5	-	%
RMS Output Noise	V _N	10Hz ≤ f ≤ 10KHz	T _J =25°C	-	0.003	-	%V _O
Ripple Rejection Ratio	R _A	V _{IN} = 5V, I _O = 1A	T _J =0°C to 70°C	60	72	-	dB

AME1117Bxxx

Parameter	Symbol	Test Condition	Min	Typ	Max	Units	
Output Voltage	V _{OUT}	V _{IN} = 5V, I _O = 0A	T _J =25°C	2.475	2.500	2.525	V
			T _J =0°C to 70°C	2.450	2.500	2.550	
Line Regulation	REG _{LINE}	V _{IN} = 4.75V to 7V, I _O = 0A	T _J =0°C to 70°C	-	-	0.2	%
Load Regulation	REG _{LOAD}	V _{IN} = 5V I _O = 0A to 1A	T _J =0°C to 70°C	-	0.1	1.0	
Dropout Voltage	V _{DROPOUT}	I _O = 0A to 1A, ΔV _O = ±1%	T _J =0°C to 70°C	-	1.2	1.45	V
Current Limit	I _S	V _{IN} = 4.75V to 7V	T _J =0°C to 70°C	1.0	1.5	-	A
Quiescent Current	I _Q	V _{IN} = 5V, I _O = 0A to 1A	T _J =0°C to 70°C	-	6.0	13	mA
Temp. Coefficient	T _C	V _{IN} = 4.75V to 7V, I _O = 0A~1A		-	0.005	-	%/°C
Temperature Stability	T _S	V _{IN} = 5V, I _O = 100mA	T _J =0°C to 70°C	-	0.5	-	%
RMS Output Noise	V _N	10Hz ≤ f ≤ 10KHz	T _J =25°C	-	0.003	-	%V _O
Ripple Rejection Ratio	R _A	V _{IN} = 5V, I _O = 1A	T _J =0°C to 70°C	60	72	-	dB



Electrical Specifications

AME1117Axxx

Parameter	Symbol	Test Condition	Min	Typ	Max	Units	
Reference Voltage	V _{REF}	V _{IN} = 5V, I _O = 10mA	T _J =25°C	1.238	1.250	1.262	V
			T _J =0°C to 70°C	1.225	1.250	1.275	
Line Regulation *	REG _{LINE}	V _{IN} = 4.75V to 7V, I _O = 10mA	T _J =0°C to 70°C	-	-	0.2	%
Load Regulation	REG _{LOAD}	V _{IN} = 5V, I _O = 10mA to 1A	T _J =0°C to 70°C	-	0.1	1.0	
Dropout Voltage	V _{DROPOUT}	I _O = 10mA to 1A, ΔV _O = ±1%	T _J =0°C to 70°C	-	1.2	1.45	V
Current Limit	I _S	V _{IN} = 2.7V to 7V	T _J =0°C to 70°C	1.0	1.5	-	A
Temp. Coefficient	T _C	V _{IN} = 2.75V to 7V, I _O = 10mA to 1A		-	0.005	-	%/°C
Adjust Pin Current	I _{ADJ}	V _{IN} = 2.75V to 7V, I _O = 10mA to 1A	T _J =0°C to 70°C	-	55	120	μA
Adjust Pin Current Change	ΔI _{ADJ}	V _{IN} = 2.75V to 7V, I _O = 10mA to 1A	T _J =0°C to 70°C	-	0.2	5.0	
Temperature Stability	T _S	V _{IN} = 5V, I _O = 100mA	T _J =0°C to 70°C	-	0.5		%
Minimum Load Current	I _O	V _{IN} = 5V		-	5.0	10	mA
RMS Output Noise	V _N	10Hz ≤ f ≤ 10KHz	T _J =25°C	-	0.003	-	%V _O
Ripple Rejection Ratio	R _A	V _{IN} = 5V, I _O = 1A	T _J =0°C to 70°C	60	72	-	dB

*Line regulation test circuit

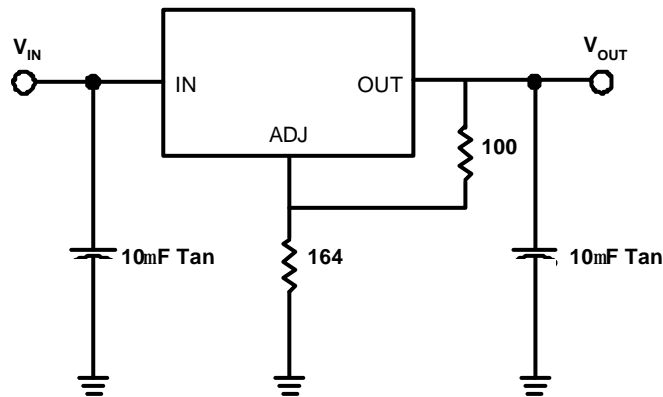

■ Application Description

1. Output Voltage Adjustment

Like most regulators, the AME1117 regulates the output by comparing the output voltage to an internally generated reference voltage. On the adjustable version, the V_{REF} is available externally as 1.25V between V_{OUT} and ADJ. The voltage ratio formed by R1 and R2 should be set to conduct 10mA (minimum output load). The output voltage is given by the following equation:

$$V_{OUT} = V_{REF} \left(1 + \frac{R2}{R1} \right) + I_{ADJ} \times R2$$

On fixed versions of AME1117, the voltage divider is provided internally.

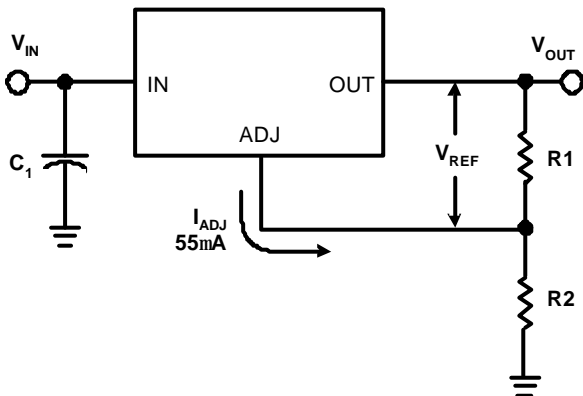

$$V_{OUT} = V_{REF} \left(1 + \frac{R2}{R1} \right) + I_{ADJ} \times R2$$

2. Thermal Protection

AME1117 has thermal protection which limits junction temperature to 150°C. However, device functionality is only guaranteed to a maximum junction temperature of +125°C.

The power dissipation and junction temperature for AME1117 is given by

$$P_D = (V_{IN} - V_{OUT}) \times I_{OUT}$$

$$T_{JUNCTION} = T_{AMBIENT} + (P_D \times \theta_{JA})$$

Note: $T_{JUNCTION}$ must not exceed 125°C

3. Current Limit Protection

AME1117 is protected against overload conditions. Current protection is triggered at typically 1.5A.

4. Stability and Load Regulation

AME1117 requires a capacitor from V_{OUT} to GND to provide compensation feedback to the internal gain stage. This is to ensure stability at the output terminal. Typically, a 10µF tantalum or 50µF aluminum electrolytic is sufficient.

(Note: It is important that the ESR for this capacitor does not exceed 0.5W.)

The output capacitor does not have a theoretical upper limit and increasing its value will increase stability. $C_{OUT} = 100\mu F$ or more is typical for high current regulator design.

For the adjustable version, the best load regulation is accomplished when the top of the resistor divider (R1) is connected directly to the output pin of the AME1117. When so connected, R_p is not multiplied by the divider ratio.

For fixed output versions, the top of R1 is internally connected to the output. The ground pin can be connected to the low side of the load in order to eliminate ground loop errors.

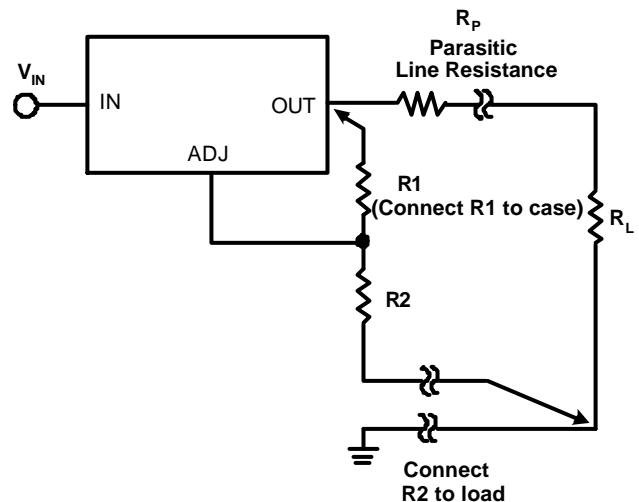



5. Thermal Consideration

The AME1117 series contain thermal limiting circuitry designed to protect itself from over-temperature conditions. Even for normal load conditions, maximum junction temperature ratings must not be exceeded. As mentioned in thermal protection section, we need to consider all sources of thermal resistance between junction and ambient. It includes junction-to-case, case-to-heat-sink interface and heat sink thermal resistance itself.

Junction-to-case thermal resistance is specified from the IC junction to the bottom of the case directly below the die. Proper mounting is required to ensure the best possible thermal flow from this area of the package to the heat sink. The case of all devices in this product series is electrically connected to the output. Therefore, if the case of the device must be electrically isolated, a thermally conductive spacer is recommended.

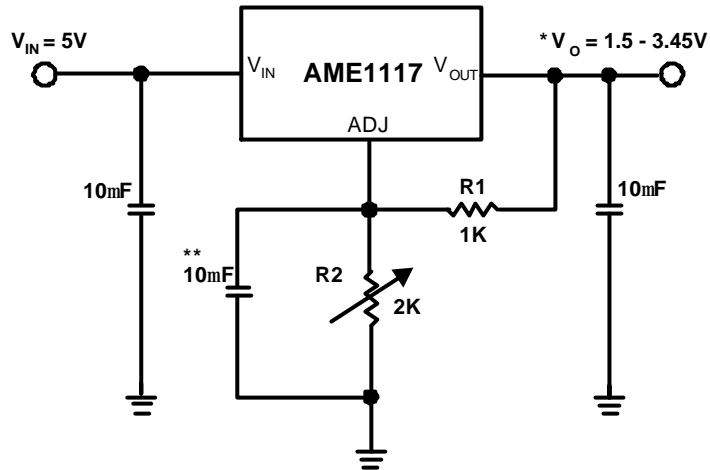
■ Advanced Applications (contd.)
Adjustable Output Voltage

Note: $* V_{OUT} = V_{REF} \left(1 + \frac{R2}{R1} \right) + I_{ADJ} \times R2$

** Optional for improved ripple rejection

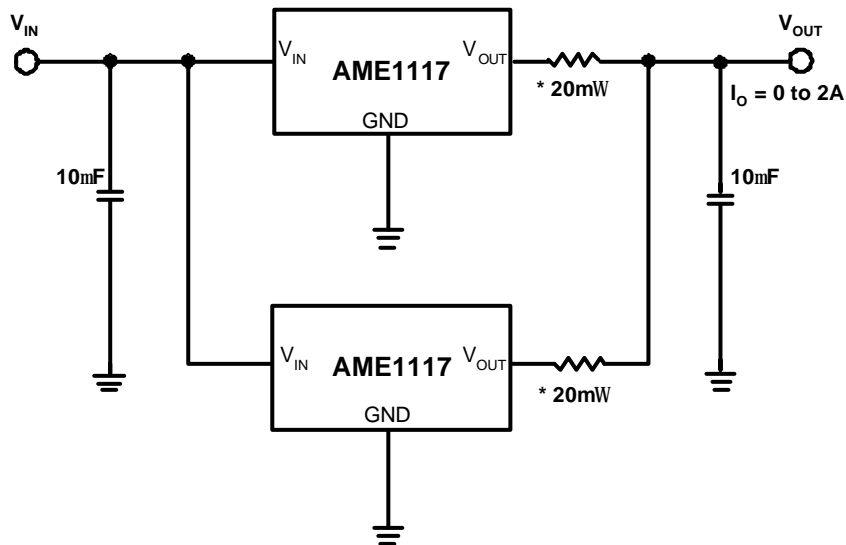
Paralleling Regulators

Note: * 20mΩ is ballast resistance
The inter - connection of #18 wire could act as ballast resistance



■ Advanced Applications

Regulator with Reference

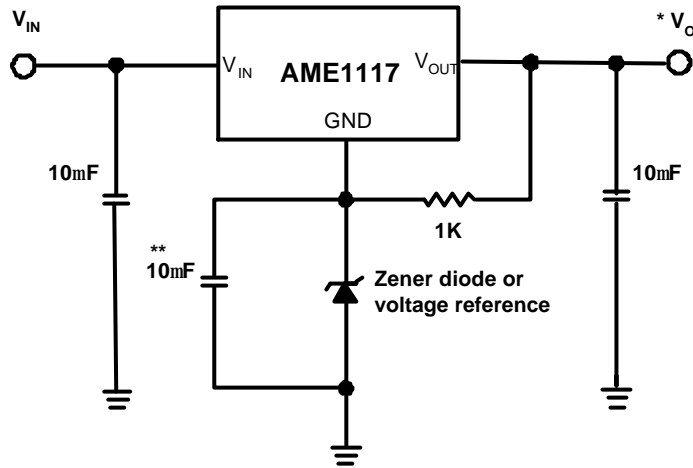

Note: * $V_o = V_{REF} + V_Z$ (V_Z : breakdown voltage of Zener diode)
** Optional for improved ripple rejection

Regulator with Reverse Diode Protection

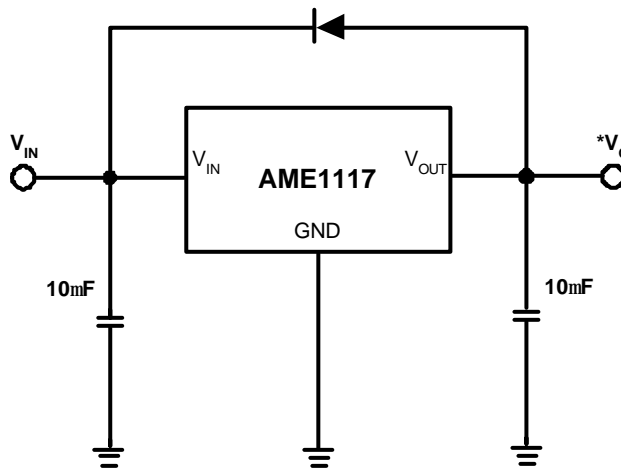



Temperature Stability
(For Fixed Voltage)

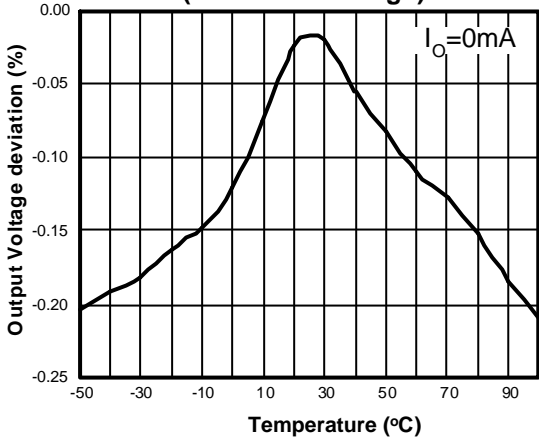

Temperature Stability
(For Adjustable Voltage)

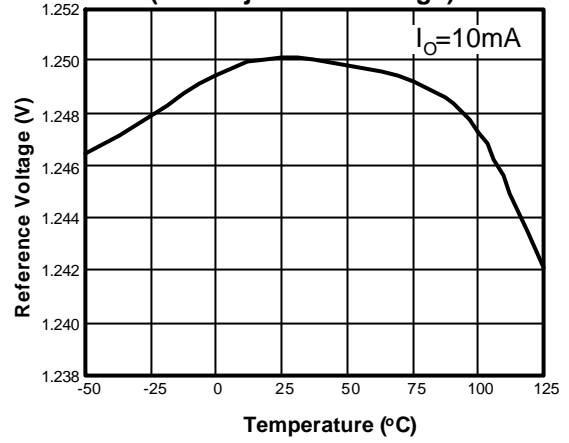

Short Circuit Current

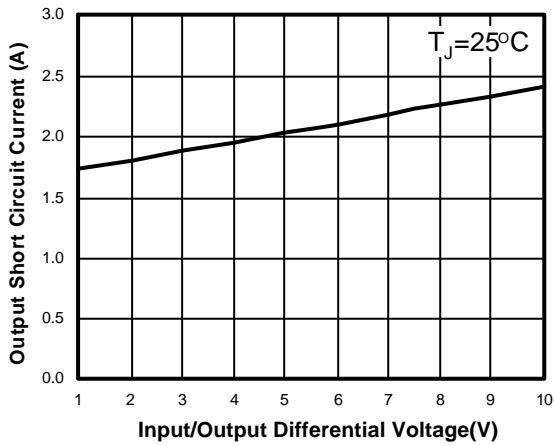

Dropout Voltage

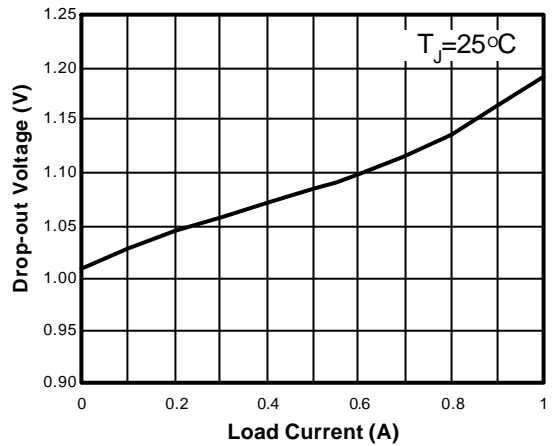

Adjust Pin Current

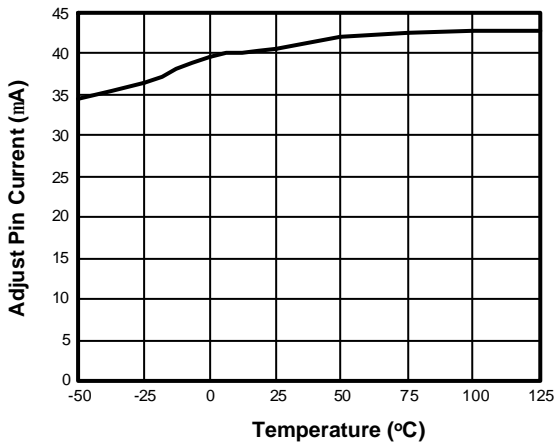

Minimum Operating Current

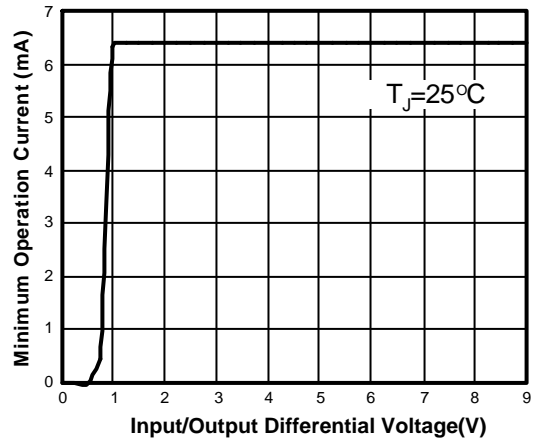



Load Transient Response

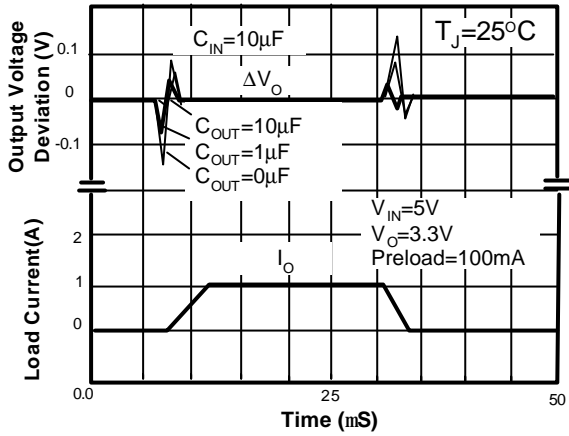

Line Transient Response

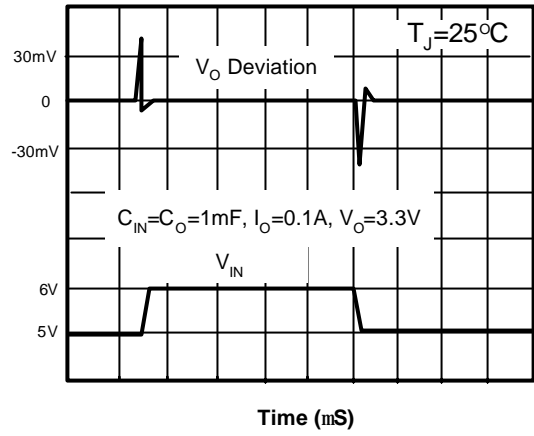

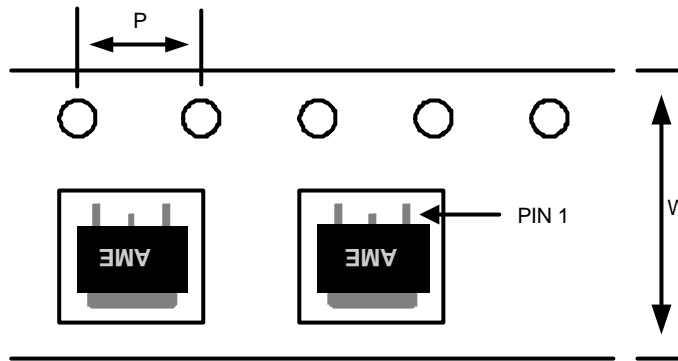
AME1117
■ Tape and Reel Dimension
TO-252-2

Carrier Tape, Number of Components Per Reel and Reel Size

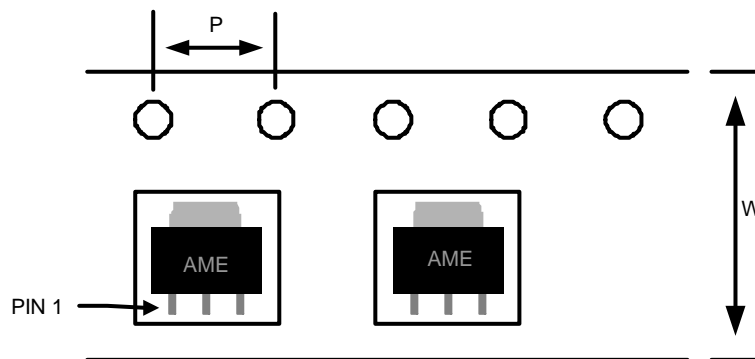
Package	Carrier Width (W)	Pitch (P)	Part Per Full Reel	Reel Size
TO-252-2	16.0±0.1 mm	4.0±0.1 mm	2500pcs	330±1 mm

SOT-223

Carrier Tape, Number of Components Per Reel and Reel Size

Package	Carrier Width (W)	Pitch (P)	Part Per Full Reel	Reel Size
SOT-223	12.0±0.1 mm	4.0±0.1 mm	2500pcs	330±1 mm

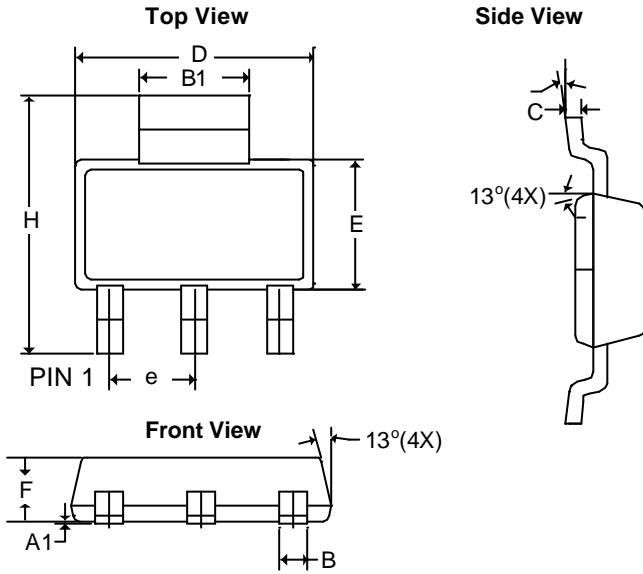

■ Package Dimension

SOT-223



SYMBOLS	MILLIMETERS		INCHES	
	MIN	MAX	MIN	MAX
A ₁	0.01	0.10	0.0004	0.0039
B	0.60	0.84	0.0236	0.0330
B ₁	2.90	3.15	0.1140	0.1240
C	0.24	0.38	0.0094	0.0150
D	6.30	6.71	0.2480	0.2640
E	3.30	3.71	0.1299	0.1460
e	2.30 BSC		0.0906 BSC	
H	6.70	7.30	0.2638	0.2874
q	0°	10°	0°	10°

TO-220-3

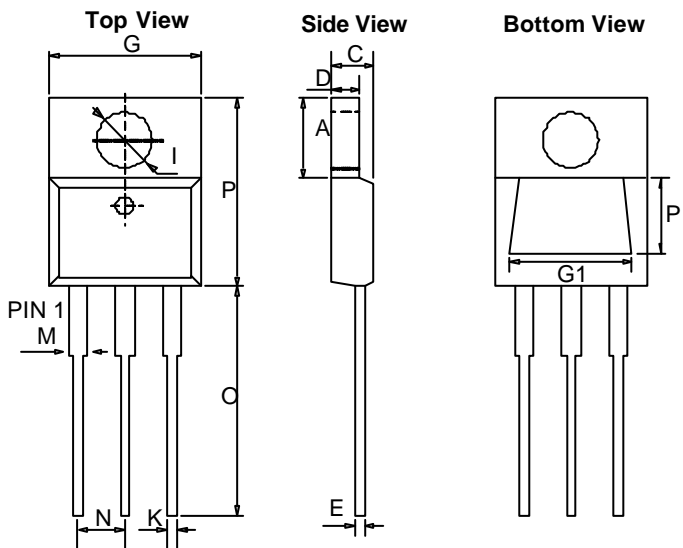

SYMBOLS	MILLIMETERS		INCHES	
	MIN	MAX	MIN	MAX
A	5.58	7.49	0.2197	0.2949
C	2.03	4.83	0.0799	0.1902
D	0.50	1.40	0.0197	0.0551
E	0.30	1.15	0.0118	0.0453
G	9.65	10.67	0.3799	0.4201
I	3.53	4.09	0.1390	0.1610
K	0.50	1.15	0.0197	0.0453
M	1.14	1.78	0.0449	0.0701
N	2.28	2.80	0.0898	0.1102
O	12.70	14.74	0.5000	0.5803
P	14.22	16.51	0.5598	0.6500
P1	5.00	5.70	0.1969	0.2244
G ₁	7.30	8.05	0.2874	0.3169

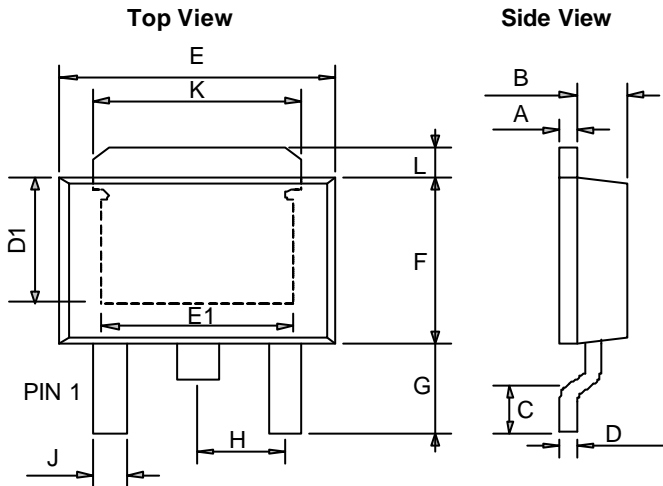
■ Package Dimension
TO-252-2

SYMBOLS	MILLIMETERS		INCHES	
	MIN	MAX	MIN	MAX
A	0.43	0.58	0.0169	0.0230
B	1.60	1.95	0.0630	0.0768
C	0.51	1.78	0.0200	0.0701
D	0.43	0.60	0.0169	0.0236
E	6.35	6.80	0.2500	0.2677
F	5.36	7.20	0.2110	0.2835
G	2.20	3.00	0.0866	0.1181
H	-	*2.30	-	*0.0906
J	-	0.97	-	0.0380
K	5.20	5.50	0.2047	0.2165
L	1.40 REF		0.0551 REF	
D1	3.80 REF		0.1496 REF	
E1	3.81	5.10	0.1500	0.2008

***: Typical Value**
Notes:

1. Controlling dimension: Millimeters.
2. Maximum lead thickness includes lead finish thickness. Minimum lead thickness is the minimum thickness of base material.



www.ame.com.tw
E-Mail: sales@ame.com.tw

Life Support Policy:

These products of AME, Inc. are not authorized for use as critical components in life-support devices or systems, without the express written approval of the president of AME, Inc.

AME, Inc. reserves the right to make changes in the circuitry and specifications of its devices and advises its customers to obtain the latest version of relevant information.

© AME, Inc. , May 2008

Document: 1014-DS1117-T.03

Corporate Headquarter

AME, Inc.

2F, 302 Rui-Guang Road, Nei-Hu District
Taipei 114, Taiwan.

Tel: 886 2 2627-8687

Fax: 886 2 2659-2989