

HSMF-C655

HSMF-C656

HSMF-C657

Bicolor Surface Mount Chip LEDs



Data Sheet

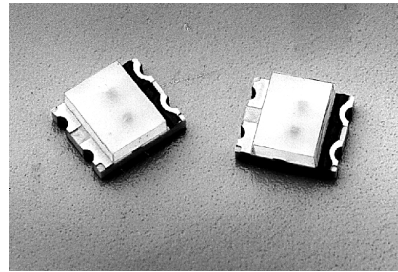

Description

The HSMF-C65x series of bicolor chip-type LEDs are designed in an industry standard package for ease of handling and use. These bicolor LEDs are available as high efficiency red/green, yellow/green, and orange/green.

The small size, low 1.1 mm profile and wide viewing angle make these LEDs excellent for backlighting applications and front panel illumination. They are compatible with IR reflow soldering processes.

Features

- Small size
- Diffuse optics
- Compatible with IR solder processes
- Three combinations available: Red/Green, Orange/Green, Yellow/Green
- Available in 8 mm tape on 7" (178 mm) diameter reels

Applications

- Symbol backlighting
- Status indication
- Front panel indicator

Part Number	Color	Parts/Reel
HSMF-C655	High Efficiency Red/ Green	3000
HSMF-C656	Yellow/ Green	3000
HSMF-C657	Orange/ Green	3000

Package Dimensions

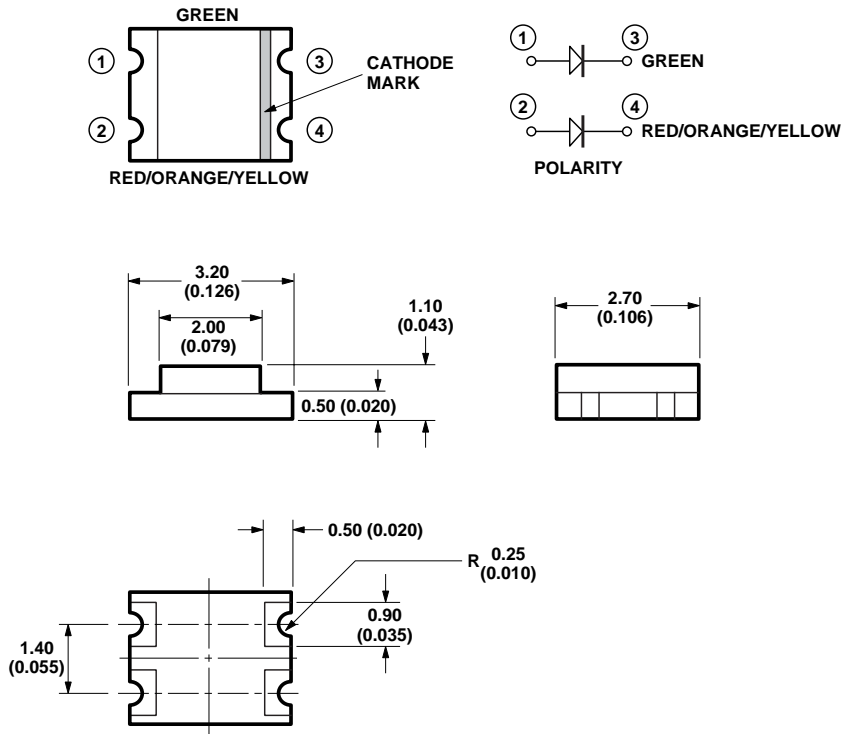

Notes:

1. Dimensions in mm.
2. Tolerance ± 0.1 mm unless otherwise noted.

Absolute Maximum Ratings at $T_A = 25^\circ\text{C}$

Parameter	HSMF-C65x	Units
DC Forward Current ^{[1], [2]}	25	mA
Power Dissipation	65	mW
Reverse Voltage ($I_R = 100 \mu\text{A}$)	5	V
LED Junction Temperature	95	$^\circ\text{C}$
Operating Temperature Range	-25 to +80	$^\circ\text{C}$
Storage Temperature Range	-30 to +85	$^\circ\text{C}$

Notes:

1. Derate Linearly as shown in Figure 4.
2. Maximum current is for entire package.

Optical Characteristics at $T_A = 25^\circ\text{C}$

Color	Luminous Intensity I_V (mcd) @ $I_F = 20\text{ mA}$		Peak Wavelength λ_{peak} (nm) Typ.	Color Dominant Wavelength λ_d ^[1] (nm) Typ.	Viewing Angle $2\theta_{1/2}$ (degrees) ^[2] Typ.	Luminous Efficacy η_V (lm/W) ^[3]
	Min.	Typ.				
High Efficiency Red	1.6	5.0	639	626	155	145
Orange	1.6	4.0	606	604	155	380
Yellow	1.6	5.0	584	586	155	500
Green	4.0	9.0	570	572	155	595

Notes:

1. The dominant wavelength, λ_d , is derived from the 1931 CIE chromaticity diagram and represents the perceived color of the device with respect to standard illuminant D65.
2. $\theta_{1/2}$ is the off-axis angle where the luminous intensity is $1/2$ the peak intensity.
3. The luminous efficacy, η_V , is the ratio of luminous flux to radiant flux, ϕ_V/ϕ_e .

Electrical Characteristics at $T_A = 25^\circ\text{C}$

Color	Forward Voltage V_F (Volts) @ $I_F = 20\text{ mA}$		Reverse Breakdown V_R (Volts) @ $I_R = 100\ \mu\text{A}$ Min.	Capacitance C (pF) $V_F = 0$, $f = 1\text{ MHz}$ Typ.	Thermal Resistance $R\theta_{J-Pin}$ ($^\circ\text{C}/\text{W}$)
	Typ.	Max.			
High Efficiency Red	1.9	2.6	5	4	325
Orange	2.1	2.6	5	4	325
Yellow	2.1	2.6	5	3	325
Green	2.2	3.0	5	8	325

Green Color Bins^[1]		
Dom. Wavelength (nm)		
Bin ID	Min.	Max.
A	561.5	564.5
B	564.5	567.5
C	567.5	570.5
D	570.5	573.5
E	573.5	576.5

Tolerance: ± 0.5 nm.

Orange Color Bins^[1]		
Dom. Wavelength (nm)		
Bin ID	Min.	Max.
A	597.0	600.0
B	600.0	603.0
C	603.0	606.0
D	606.0	609.0
E	609.0	612.0
F	612.0	615.0

Tolerance: ± 1 nm.

Yellow/Amber Color Bins^[1]		
Dom. Wavelength (nm)		
Bin ID	Min.	Max.
A	582.0	584.5
B	584.5	587.0
C	587.0	589.5
D	589.5	592.0
E	592.0	594.5
F	594.5	597.0

Tolerance: ± 0.5 nm.

Note:

1. Bin categories are established for classification of products. Products may not be available in all bin categories. Please contact your Avago representative for information on currently available bins.

Luminous Intensity Bin Limits^[1]

Bin ID	Minimum (mcd)	Maximum (mcd)
A	0.11	0.18
B	0.18	0.29
C	0.29	0.45
D	0.45	0.72
E	0.72	1.10
F	1.10	1.80
G	1.80	2.80
H	2.80	4.50
J	4.50	7.20
K	7.20	11.20
L	11.20	18.00
M	18.00	28.50
N	28.50	45.00
P	45.00	71.50
Q	71.50	112.50
R	112.50	180.00
S	180.00	285.00
T	285.00	450.00
U	450.00	715.00
V	715.00	1125.00
W	1125.00	1800.00
X	1800.00	2850.00
Y	2850.00	4500.00

Tolerance: $\pm 15\%$.

Note:

1. Bin categories are established for classification of products. Products may not be available in all bin categories. Please contact your Avago representative for information on currently available bins.

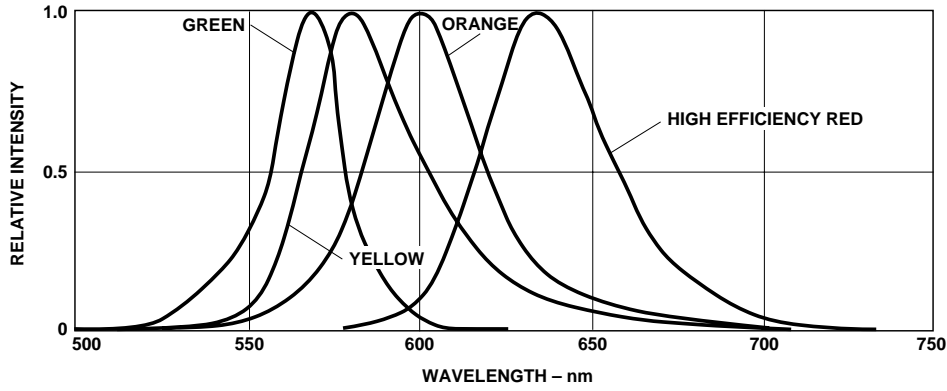

Figure 1. Relative Intensity vs. Wavelength.

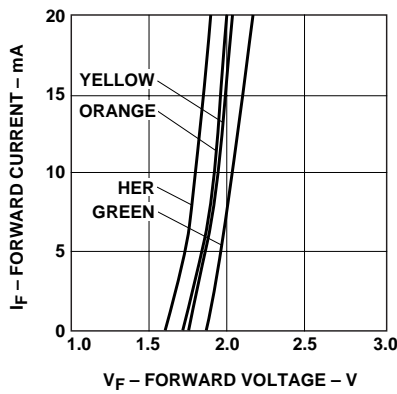

Figure 2. Forward Current vs. Forward Voltage.

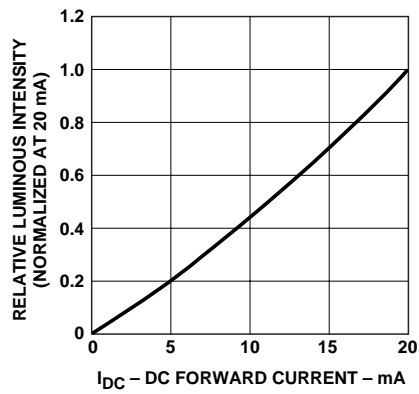

Figure 3. Relative Luminous Intensity vs. DC Forward Current.

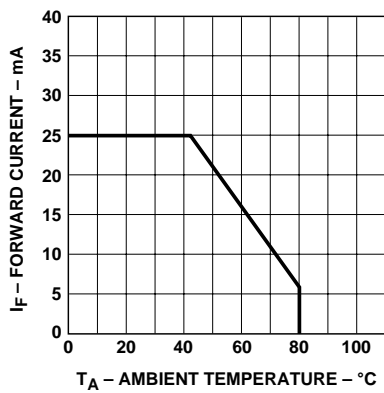

Figure 4. Maximum DC Current vs. Ambient Temperature.

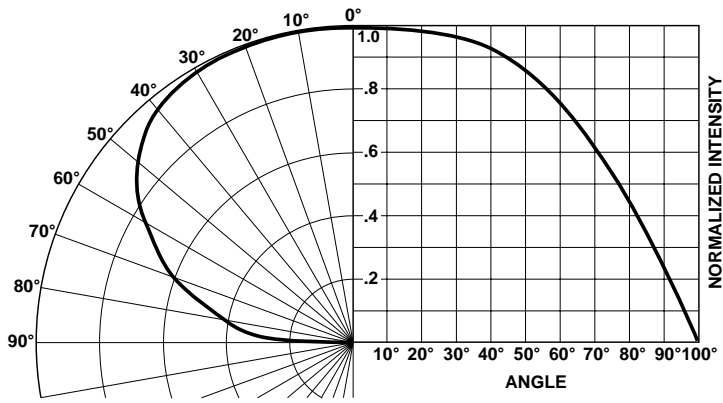

Figure 5. Intensity vs. Angle.

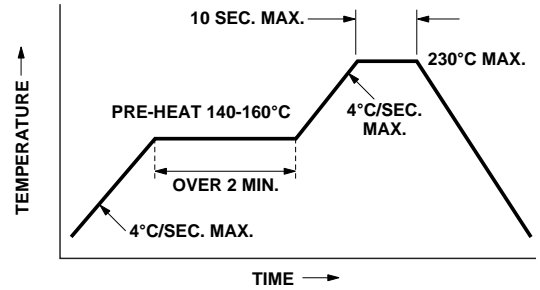

Figure 6. Recommended Reflow Soldering Profile.

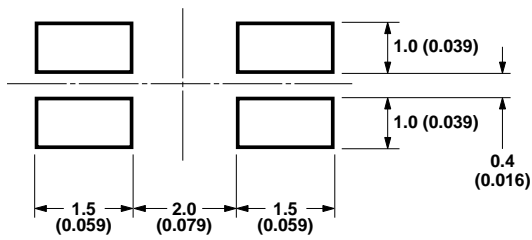

Figure 7. Recommended Solder Pattern.

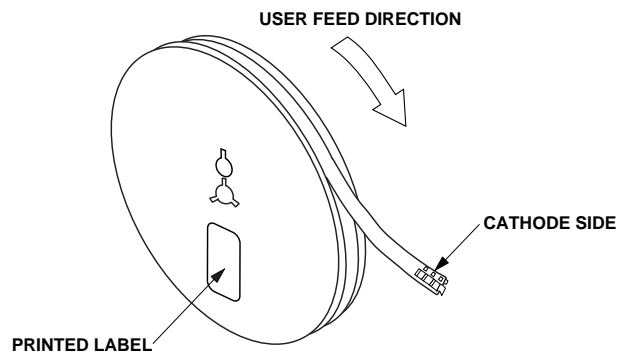

Figure 8. Reeling Orientation.

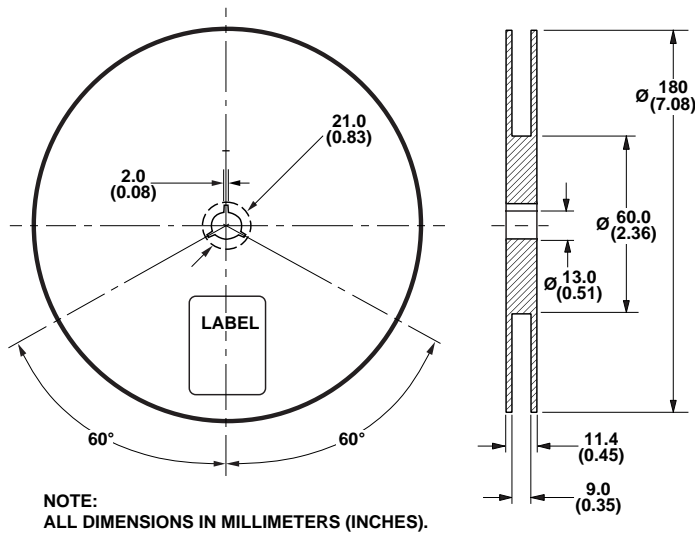

Figure 9. Reel Dimensions.

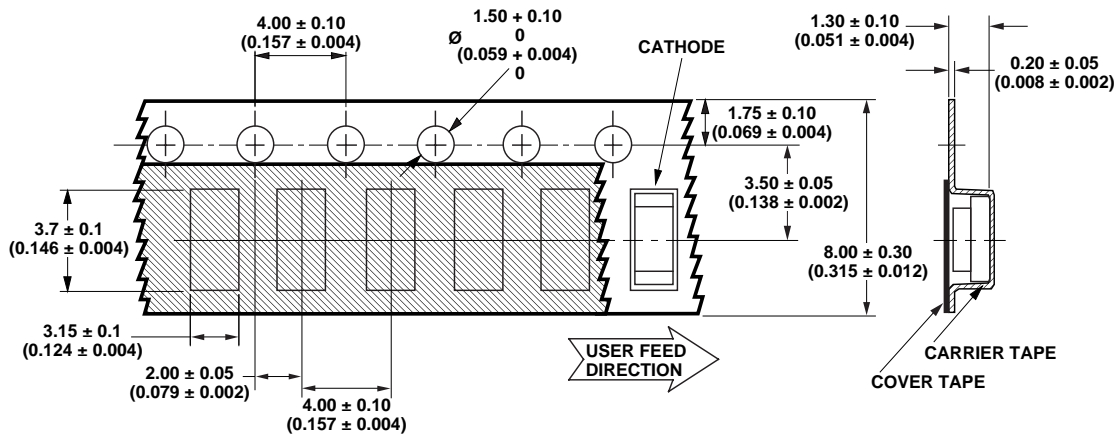

Figure 10. Tape Dimensions.

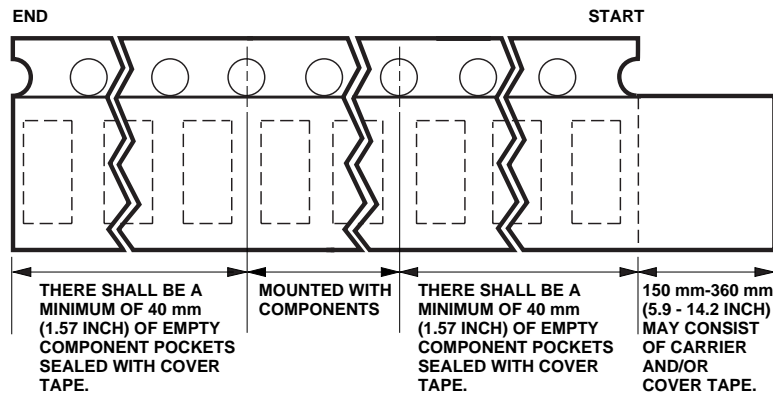

Figure 11. Tape Leader and Trailer Dimensions.

Storage Condition: 5 to 30° C @ 60% RH max.

Baking is required under the condition:

- a) the blue silica gel indicator becoming white/transparent color
- b) the pack has been opened for more than 1 week

Baking recommended condition: 60 ± 5° C for 20 hours.

For product information and a complete list of distributors, please go to our website: www.avagotech.com

Avago, Avago Technologies, and the A logo are trademarks of Avago Technologies Limited in the United States and other countries. Data subject to change. Copyright © 2006 Avago Technologies Limited. All rights reserved. Obsoletes 5988-4447EN 5988-7313EN November 5, 2006

