

MBR2040FCT THRU MBR20200FCT

List

List..... 1

Package outline..... 2

Features..... 2

Mechanical data..... 2

Maximum ratings2

Electrical characteristics..... 2

Rating and characteristic curves..... 3

Pinning information.....4

Marking..... 4

Tube packing.....4

Suggested thermal profiles for soldering processes..... 5

High reliability test capabilities.....6

MBR2040FCT THRU MBR20200FCT

20A High Barrier Power Schottky Rectifiers - 40V-200V

Features

- Low power loss, high efficiency.
- High current capability
- High surge capability.
- Guardring for overvoltage protection.
- Low stored charge majority carrier conduction
- Silicon epitaxial planar chip, metal silicon junction.
- Lead-free parts meet environmental standards of MIL-STD-19500 /228
- Suffix "-H" indicates Halogen-free parts, ex. MBR2040FCT-H.

Mechanical data

- Epoxy : UL94-V0 rated flame retardant
- Case : JEDEC ITO-220AB molded plastic body over passivated chip
- Lead : Axial leads, solderable per MIL-STD-202, Method 208 guaranteed
- Polarity: As marked
- Mounting Position : Any
- Weight : Approximated 1.70gram

Package outline

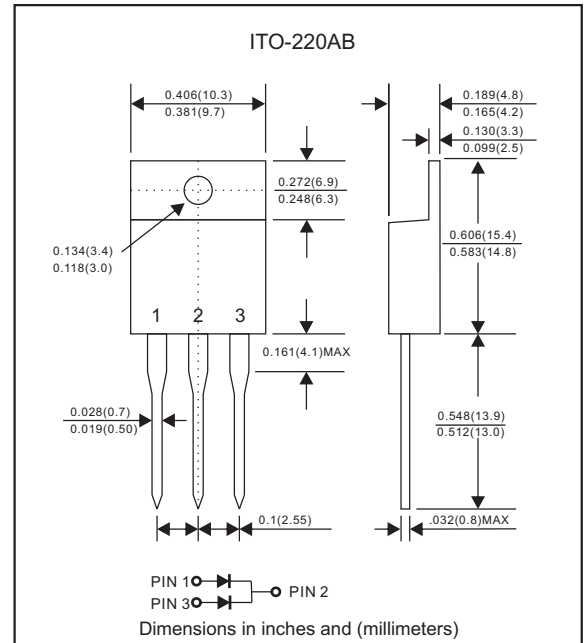

Maximum ratings (AT $T_A=25^\circ\text{C}$ unless otherwise noted)

PARAMETER	SYMBOLS	MBR 2040FCT	MBR 2045FCT	MBR 2050FCT	MBR 2060FCT	MBR 2080FCT	MBR 20100FCT	MBR 20150FCT	MBR 20200FCT	UNIT
Maximum repetitive peak reverse voltage	V_{RRM}	40	45	50	60	80	100	150	200	V
Maximum RMS voltage	V_{RMS}	28	31.5	35	42	56	70	105	140	V
Maximum DC blocking voltage	V_{DC}	40	45	50	60	80	100	150	200	V
Maximum average forward rectified current Per device	I_o	20								A
Peak forward surge current 8.3ms single half sine-wave(JEDEC method)	I_{FSM}	150								A
Operating junction temperature range	T_J	-55 to +150						-55 to +175		$^\circ\text{C}$
Storage temperature range	T_{STG}	-65 to +175								$^\circ\text{C}$

Electrical characteristics (AT $T_A=25^\circ\text{C}$ unless otherwise noted)

PARAMETER	SYMBOLS	MBR 2040FCT	MBR 2045FCT	MBR 2050FCT	MBR 2060FCT	MBR 2080FCT	MBR 20100FCT	MBR 20150FCT	MBR 20200FCT	UNIT
Maximum forward voltage per leg at $I_F=10\text{A}$ at $I_F=20\text{A}$	V_F	0.65 0.84		0.75 0.85		0.85 0.95		0.92 1.00		V V
Maximum DC reverse current at $T_J=25^\circ\text{C}$ at rated DC blocking voltage at $T_J=125^\circ\text{C}$	I_R	0.05 10				0.01 10				mA mA

Thermal characteristics

PARAMETER	SYMBOLS	MBR 2040FCT	MBR 2045FCT	MBR 2050FCT	MBR 2060FCT	MBR 2080FCT	MBR 20100FCT	MBR 20150FCT	MBR 20200FCT	UNIT
Typical thermal resistance junction to case per leg	$R_{\theta JC}$	2.0								$^\circ\text{C}/\text{W}$

Rating and characteristic curves (MBR2040FCT THRU MBR20200FCT)

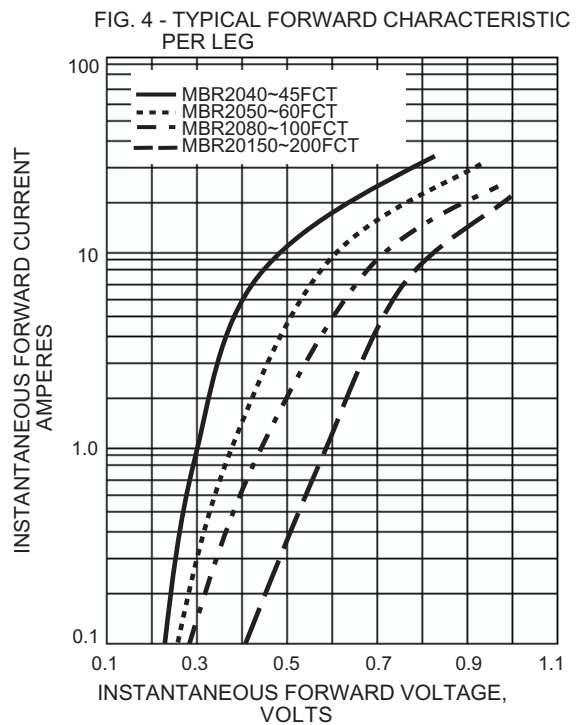
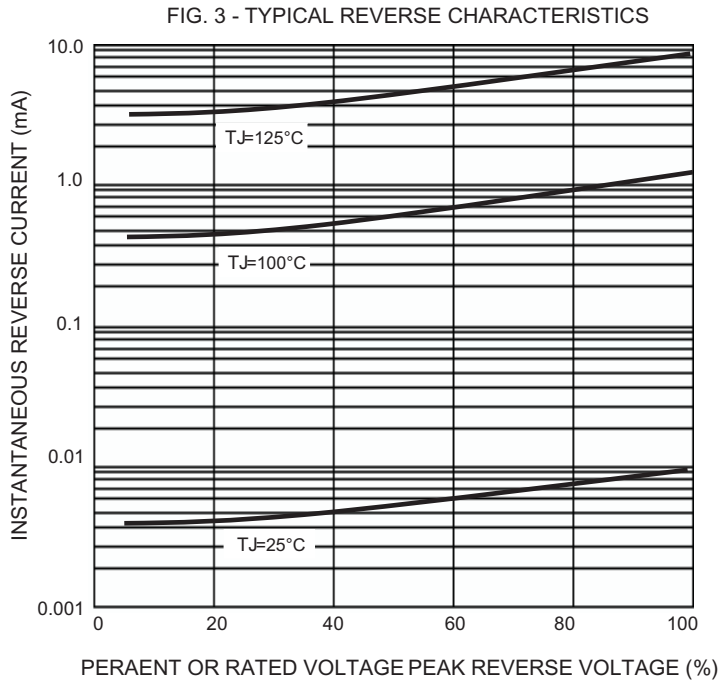
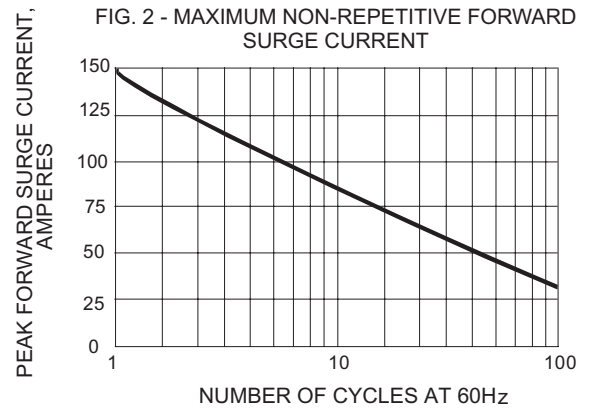
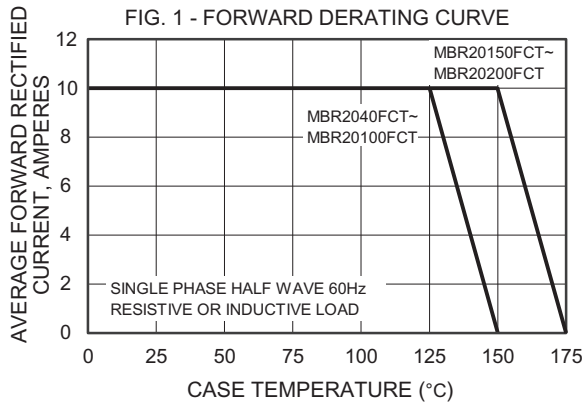

MBR2040FCT THRU MBR20200FCT

Pinning information

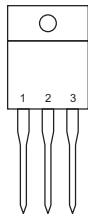
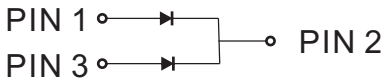
Pin	Simplified outline	Symbol
Pin1 anode Pin2 cathode Pin3 anode		

Marking

Type number	Marking code
MBR2040FCT	MBR2040FCT
MBR2045FCT	MBR2045FCT
MBR2050FCT	MBR2050FCT
MBR2060FCT	MBR2060FCT
MBR2080FCT	MBR2080FCT
MBR20100FCT	MBR20100FCT
MBR20150FCT	MBR20150FCT
MBR20200FCT	MBR20200FCT

Tube packing

PACKAGE	TUBE (pcs)	TUBE SIZE (m/m)	BOX (pcs)	INNER BOX (m/m)	CARTON SIZE (m/m)	CARTON (pcs)	APPROX. GROSS WEIGHT (kg)
ITO-220AB	50	525*32*7.0	1,000	555*150*40	580*230*175	5,000	15.0

MBR2040FCT THRU MBR20200FCT

Suggested thermal profiles for soldering processes

1. Lead free temperature profile wave-soldering

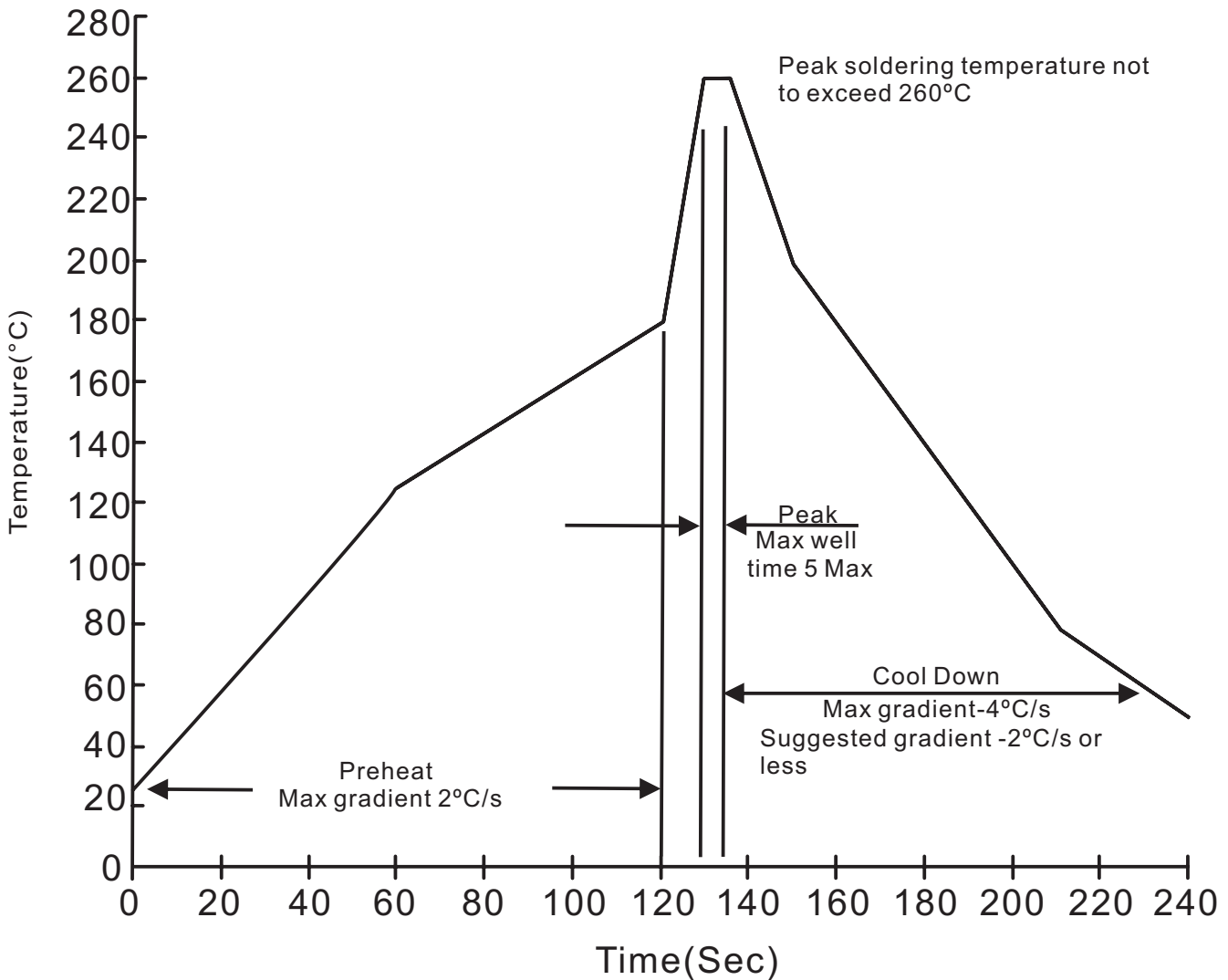

MBR2040FCT THRU MBR20200FCT

High reliability test capabilities

Item Test	Conditions	Reference
1. Solder Resistance	at $260\pm 5^{\circ}\text{C}$ for $10\pm 2\text{sec}$. immerse body into solder $1/16''\pm 1/32''$	MIL-STD-750D METHOD-2031
2. Solderability	at $245\pm 5^{\circ}\text{C}$ for 5 sec.	MIL-STD-202F METHOD-208
3. High Temperature Reverse Bias	$V_R=80\%$ rate at $T_J=150^{\circ}\text{C}$ for 168 hrs.	MIL-STD-750D METHOD-1038
4. Forward Operation Life	Rated average rectifier current at $T_A=25^{\circ}\text{C}$ for 500hrs.	MIL-STD-750D METHOD-1027
5. Intermittent Operation Life	$T_A = 25^{\circ}\text{C}$, $I_F = I_O$ On state: power on for 5 min. off state: power off for 5 min. on and off for 500 cycles.	MIL-STD-750D METHOD-1036
6. Pressure Cooker	$15P_{SIG}$ at $T_A=121^{\circ}\text{C}$ for 4 hrs.	JESD22-A102
7. Temperature Cycling	-55°C to $+125^{\circ}\text{C}$ dwelled for 30 min. and transferred for 5min. total 10 cycles.	MIL-STD-750D METHOD-1051
8. Forward Surge	8.3ms single half sine-wave , one surge.	MIL-STD-750D METHOD-4066-2
9. Humidity	at $T_A=85^{\circ}\text{C}$, RH=85% for 1000hrs.	MIL-STD-750D METHOD-1021
10. High Temperature Storage Life	at 175°C for 1000 hrs.	MIL-STD-750D METHOD-1031