

NOTES:

1. C REPRESENTS A CRITICAL DIMENSION.
2. PUSHOUT FORCE SHALL BE 1 LB. MIN.
3. GOLD AREA TO APPEAR ON POST.
4. TAILS TO BE SHEARED TO DIMENSION SHOWN. (FOR HAND TOOLING ONLY)
5. TO BE VALID ALL PART NUMBERS MUST MEET THE FOLLOWING PARAMETERS: THE BOARD SPACE RANGE, POST HEIGHT MIN. AND BOARD + POST COMBINATION FOR EACH STYLE.
6. MAX BURR: .003[.08] ON CUT TAIL.
7. MAX CUT FLASH TO BE .010[.25] ON CRITICAL AREAS AS SHOWN.
8. AVAILABLE ONLY W/BOARD SPACE .215[5.46] TOP .610[15.49].
9. PARTS TO BE ASSEMBLED WITH ALIGNMENT HOLES (IN BODY) FACING THE TAILS
10. LOWER BODY MAY BE BLACK OR WHITE.
11. FILL BODY SO THAT THE LEAD IN OF THE CORE IS ON THE TAIL SIDE.
12. MAX HEIGHT VARIATION BETWEEN ROWS: .005[0.13].
13. FOR ADDED MECHANICAL STABILITY, SAMTEC RECOMMENDS MECHANICAL BOARD SPACERS BE USED IN APPLICATIONS WITH GOLD OR SELECTIVE GOLD PLATED CONNECTORS. CONTACT IPG@SAMTEC.COM FOR MORE INFORMATION.
14. SUB-FW-50-03-XX-D-280-015 TO USE T-1S15-08, SUB-FW-50-05-XX-D-400-065 TO USE T-1S15-03.

DO NOT SCALE FROM THIS PRINT

PATENT NUMBERS
5713755 / 5961339

FW-XX-XX-XX-D-XXX-XXX-XX

POSITION SPEC
No. OF POS PER ROW
-02 THRU -50

LEAD STYLE
-03: USE T-1S15-XX-X
-05: USE T-1S15-XX-X
(SEE TABLE 1)

PLATING
-G: GOLD, 10 Au / 50 Ni MIN ON CONTACT, 3 Au / 50 Ni MIN ON TAIL
-F: FLASH SELECTIVE, 3 Au / 50 Ni MIN ON CONTACT, MATTE TIN TAIL
-L: LIGHT SELECTIVE, 10 Au / 50 Ni MIN ON CONTACT, MATTE TIN TAIL
-H: HEAVY GOLD, 30 Au / 50 Ni MIN ON CONTACT, 3 Au / 50 Ni MIN ON TAIL
-LM: LIGHT SELECTIVE, 10 Au / 50 Ni MIN ON CONTACT, MATTE TIN TAIL
-FM: FLASH SELECTIVE, 3 Au / 50 Ni MIN ON CONTACT, MATTE TIN TAIL

DOUBLE ROW
(SEE TABLE 1 FOR BODY STYLE)

OPTION

- P: PICK & PLACE PAD (USE PPP-25) (USE PPP-25-NT WITH -TR ONLY) (SEE FIG. 3, SHT 2) (5 POS. MIN)
- TR: TAPE & REEL
.6875[17.46] MAX OVERALL HEIGHT AVAILABLE FOR -TR. MAX OVERALL HEIGHT = POST + BOARDSPACE + PAD + ALIGNMENT PIN = .6875[17.46]
- ES: END SHROUDS (SEE FIG. 5, SHT 2) (9 POS PER ROW MIN) (MAX POST: .075[1.91]) (SEE NOTE 8)
- EP: GUIDE POST (FIG. 6, SHT 3) (9 POS PER ROW MIN) (MAX POST: .075[1.91]) (USE ONLY WHEN MATING WITH CLP) (SEE NOTE 8)
- A: ALIGNMENT PIN (MOLDED OR STAKED, SAMTEC'S DISCRETION ON WHICH) (SEE FIG. 7 & 8 SHT 3) (STAKED: 6 POS. MIN) (MOLDED: 3 POS. MIN) (SEE NOTE 8)

POST HEIGHT (SEE NOTE 5)
.065[1.65] MIN
POST + BOARD SPACE = "F" =
-03: .150-.400 [3.81-10.16]
*.401-.675 [10.19-17.15]
-05: *.150-.400 [3.81-10.16]
.401-.675 [10.19-17.15]

BOARD SPACE OPTION (SEE NOTE 5)
SEE TABLE 1
-03 LEAD STYLE (.085[2.16] MIN - .335[8.51] MAX)
-05 LEAD STYLE (.248[6.30] MIN - .610[15.49] MAX)
MAX = "A" - POST (SEE TABLE 1)

* = FOR EXISTING CUSTOMERS ONLY

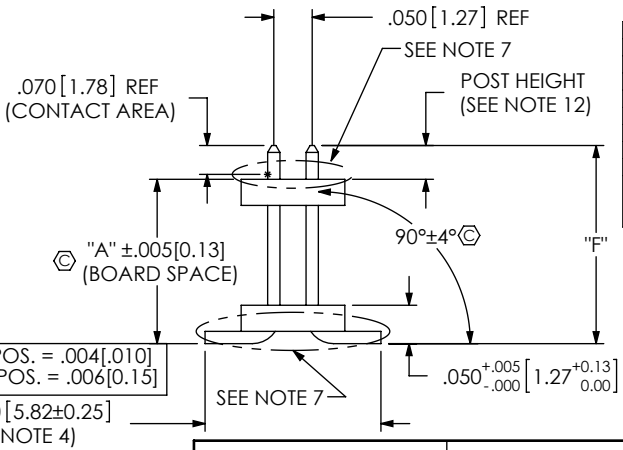
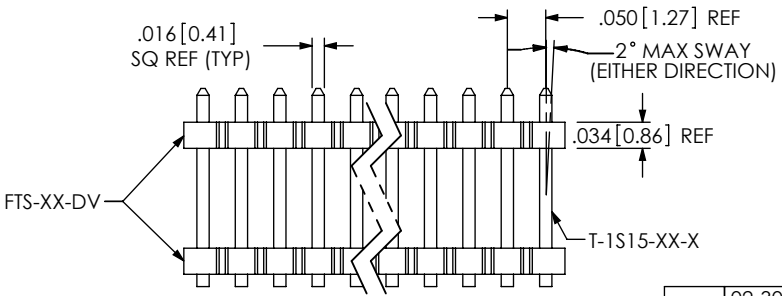
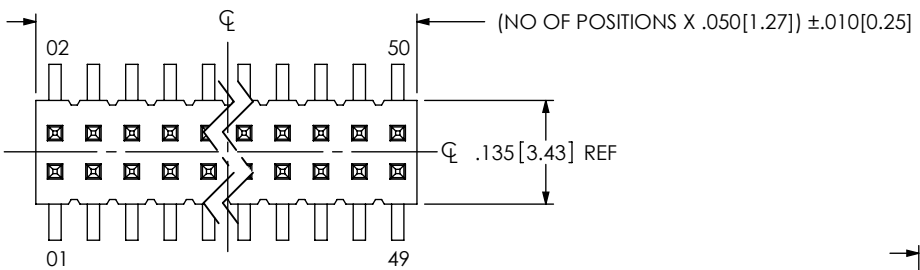

C	02-30 POS. = .004[0.10]
C	31-50 POS. = .006[0.15]
	.229 ± .010 [5.82 ± 0.25] (SEE NOTE 4)

LEAD STYLE	OPTIONS	OVERALL HEIGHT	PACKAGING TUBE	PLUG
-03	-A-P	.150 - .650	PT-FW005-D-03-P	TP-03
-03	NONE, A	.150 - .225	PT-FW005-D-03-P	TP-03
-03	NONE, A	.226 - .309	PT-FW005-D-03-P	TP-03
-03	NONE, A	.310 - .400	PT-FW005-D-03-P	TP-03
-05	NONE, A	.310 - .800	PT-FW006-D-05-P	TP-03
-05	-A-P	.310 - .650	PT-FW006-D-05-P	TP-03
-05	-A-P	.651 - .800	PT-FW006-D-05-P	TP-03
-03, -05	-ES, -EP, -ES-A, -ES-A-P, -ES-P, -EP-A, -EP-P, -EP-A-P	ALL	PT-1-24-01-71	TP-03

PACKAGING NOTE:
TUBE POSITIONS 5-50, LAYER PACKAGE ALL OTHERS

LEAD STYLE	"F" RANGE	TERMINAL PIN
-03	.150-.299	T-1S15-04-X
-03	.300-.400	T-1S15-03-X
-05	.401-.675	T-1S15-03-X

(SEE NOTE 14)

LEAD STYLE	"A" RANGE	"C" RANGE (SEE SHEET 2, FIG 5 & 6)	"D" RANGE (SEE SHEET 2, FIG 5 & 6)	BODY STYLE		FIG
				UPPER BODY	LOWER BODY	
-03	.085 - .214 [2.16 - 5.44]	N/A	N/A	FTS-XX-DV	FTS-XX-DV	1
-03	.215 - .335 [5.46 - 8.51]	.293 - .423 REF [7.45 - 10.75]	.413 - .543 REF [10.50 - 13.79]	FTSH-XX-D	*FTSH-XX-D	2 (SEE SHEET 2)
-05	.248 - .610 [6.30 - 15.49]	.326 - .698 REF [8.28 - 17.73]	.446 - .818 REF [11.32 - 20.78]	FTSH-XX-D	FTSH-XX-D	4 (SEE SHEET 2)

* FOR BKT MACHINE, USE FW-XX-D

UNLESS OTHERWISE SPECIFIED, DIMENSIONS ARE IN INCHES. TOLERANCES ARE:
DECIMALS ANGLES
.XX: ±.01 [.3] 5°
.XXX: ±.005 [.13]
.XXXX: ±.0020 [.051]

PROPRIETARY NOTE
THIS DOCUMENT CONTAINS INFORMATION CONFIDENTIAL AND PROPRIETARY TO SAMTEC, INC. AND SHALL NOT BE REPRODUCED OR TRANSFERRED TO OTHER DOCUMENTS OR DISCLOSED TO OTHERS OR USED FOR ANY PURPOSE OTHER THAN THAT WHICH IT WAS OBTAINED WITHOUT THE EXPRESSED WRITTEN CONSENT OF SAMTEC, INC.



520 PARK EAST BLVD, NEW ALBANY, IN 47150
PHONE: 812-944-6733 FAX: 812-948-5047
e-Mail: info@SAMTEC.com code 53322

MATERIAL: DO NOT SCALE DRAWING SHEET SCALE: 4:1
BODY: LCP, UL 94 VO, COLOR: FTS-50-DV & FTSH-50-D: BLACK FW-50-D: NATURAL
TERMINAL: PHOS BRONZE
MAX FLASH ALLOWED: .002[0.05]
MAX GATE VESTIGE: .002[0.05]
F:\DWG\MISC\MKTG\FW-XX-XX-XX-D-XXX-XXX-XX-MKT.SLDDRW

DESCRIPTION:
.050 X .050 SURFACE MOUNT BOARD SPACERS
DWG. NO.
FW-XX-XX-XX-D-XXX-XXX-XX
BY: BRATCHER 11-03-1994 SHEET 1 OF 3

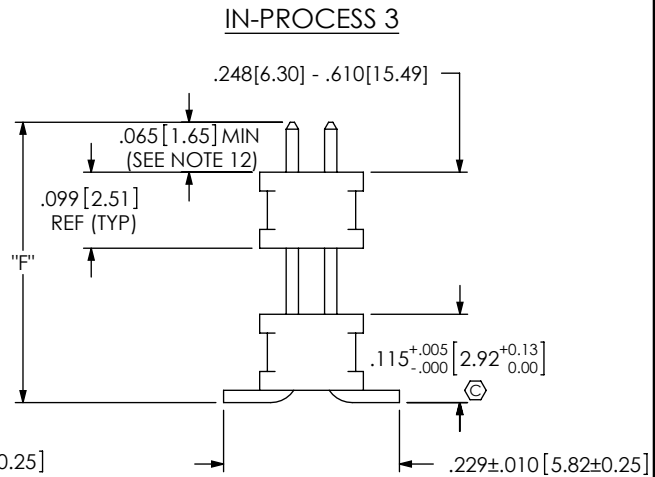
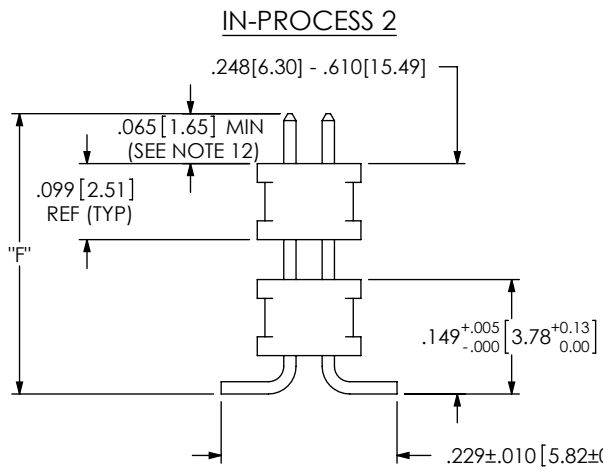
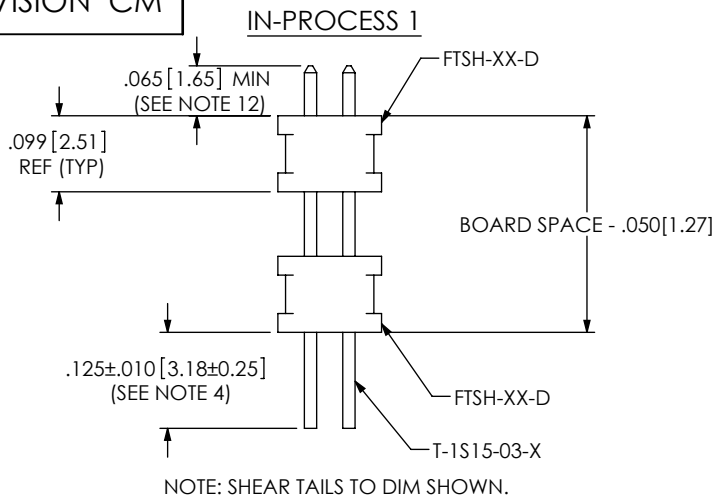

FIG 4
(IN-PROCESS 1 MAY BE BUILT WITH M30 MACHINE)
DIFFERENT AS SHOWN, OTHERWISE THE SAME AS FIG 1

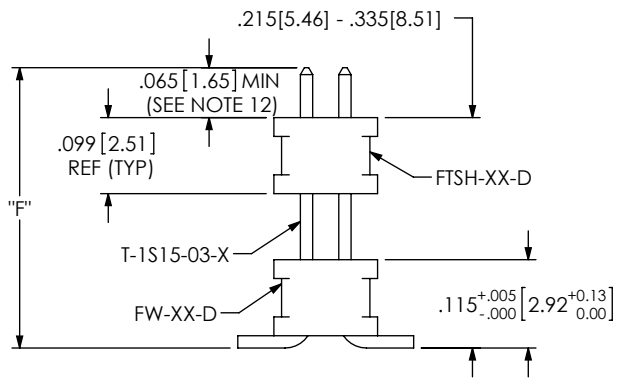

FIG 2
(BKT MACHINE)
DIFFERENT AS SHOWN, OTHERWISE THE SAME AS FIG 1

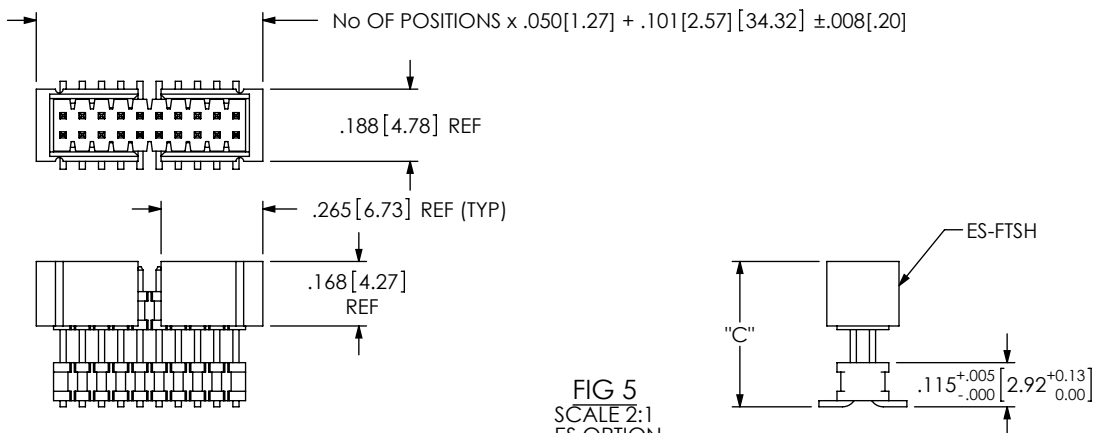

FIG 5
SCALE 2:1
-ES OPTION
DIFFERENT AS SHOWN, OTHERWISE THE SAME AS FIG 1
9 POSITION MINIMUM (SEE NOTE 8)

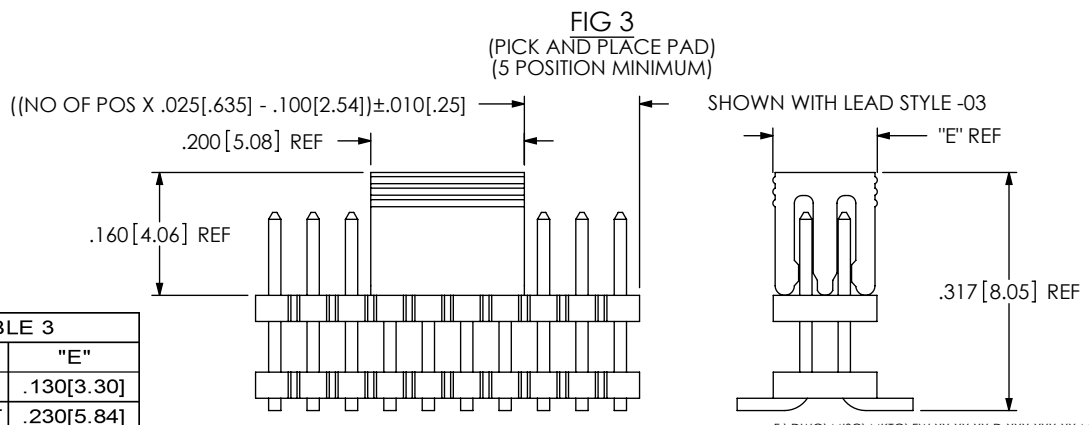

TABLE 3	
PART No.	"E"
PPP-25	.130 [3.30]
PPP-25-NT	.230 [5.84]

F:\DWG\MISC\MKTG\FW-XX-XX-D-XXX-XXX-XX-MT.SLDDRW

PROPRIETARY NOTE
THIS DOCUMENT CONTAINS INFORMATION CONFIDENTIAL AND PROPRIETARY TO SAMTEC, INC. AND SHALL NOT BE REPRODUCED OR TRANSFERRED TO OTHER DOCUMENTS OR DISCLOSED TO OTHERS OR USED FOR ANY PURPOSE OTHER THAN THAT WHICH IT WAS OBTAINED WITHOUT THE EXPRESSED WRITTEN CONSENT OF SAMTEC, INC.

DO NOT SCALE DRAWING

SHEET SCALE: 4:1

520 PARK EAST BLVD, NEW ALBANY, IN 47150
PHONE: 812-944-6733 FAX: 812-948-5047
e-Mail info@SAMTEC.com code 55322

DESCRIPTION:
.050 x .050 SURFACE MOUNT BOARD SPACERS

DWG. NO.
FW-XX-XX-XX-D-XXX-XXX-XX

BY: BRATCHER 11-03-1994 SHEET 2 OF 3

REVISION CM

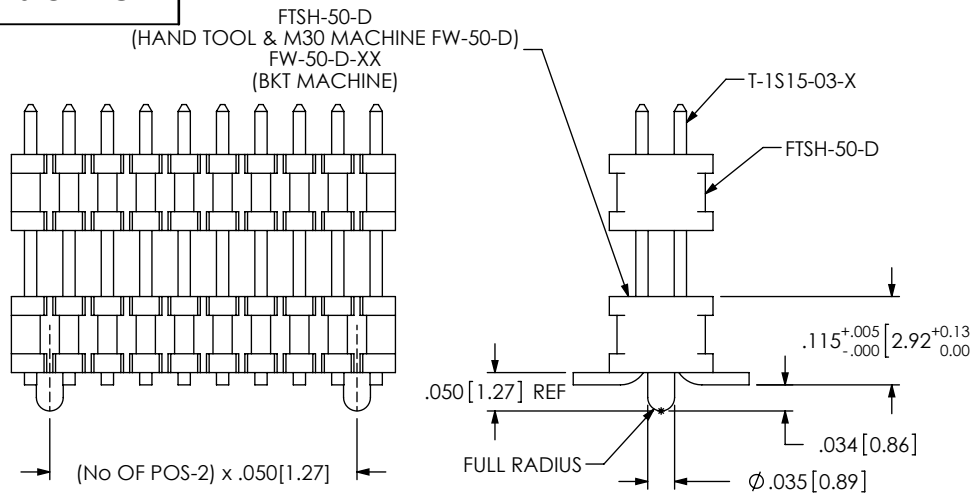

FIG 7
-A OPTION (MOLDED)
MOLD 3 POSITION MIN
DIFFERENT AS SHOWN OTHERWISE SAME AS FIG 1

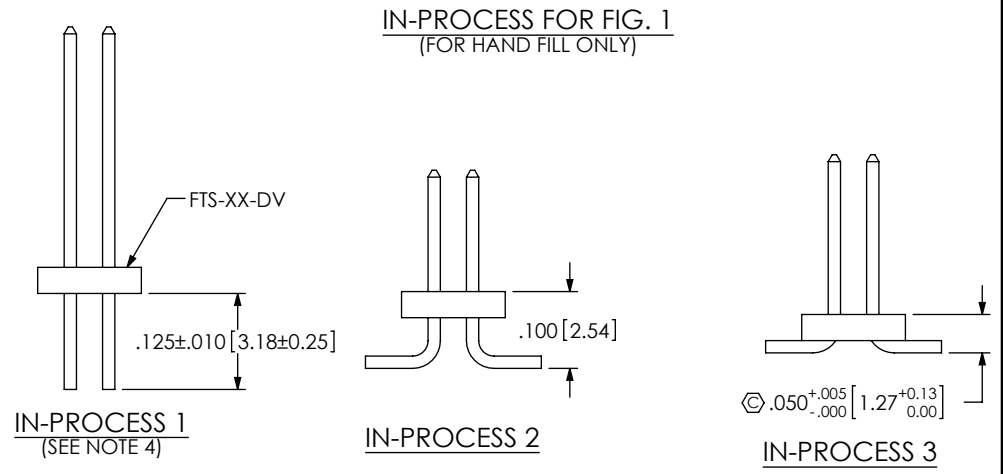

FIG 6
-EP OPTION
USE ONLY WHEN MATING TO CLP
(9 POSITION MIN)
(SEE NOTE 8)
DIFFERENT AS SHOWN, OTHERWISE SAME AS FIG 1

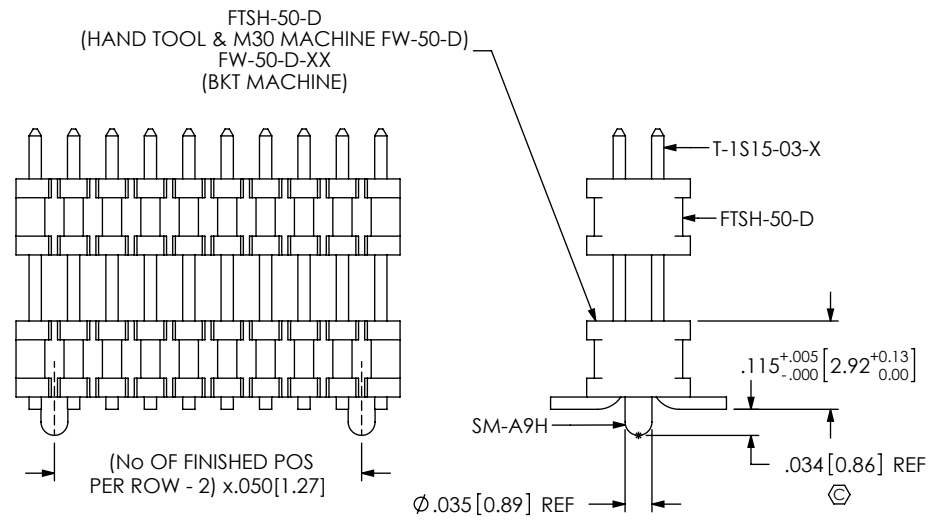
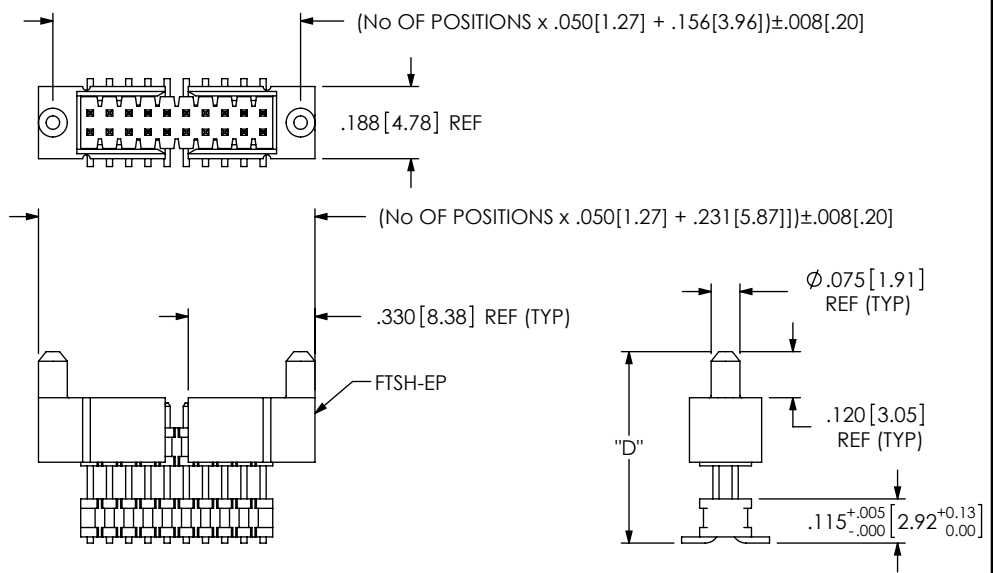

FIG 8
-A OPTION (STAKED)
6 POSITION MIN
DIFFERENT AS SHOWN OTHERWISE SAME AS FIG 1



PROPRIETARY NOTE
THIS DOCUMENT CONTAINS INFORMATION CONFIDENTIAL AND PROPRIETARY TO SAMTEC, INC. AND SHALL NOT BE REPRODUCED OR TRANSFERRED TO OTHER DOCUMENTS OR DISCLOSED TO OTHERS OR USED FOR ANY PURPOSE OTHER THAN THAT WHICH IT WAS OBTAINED WITHOUT THE EXPRESSED WRITTEN CONSENT OF SAMTEC, INC.

DO NOT SCALE DRAWING

SHEET SCALE: 4:1

samtec

520 PARK EAST BLVD, NEW ALBANY, IN 47150
PHONE: 812-944-6733 FAX: 812-948-5047
e-Mail info@SAMTEC.com code 55322

DESCRIPTION:
.050 x .050 SURFACE MOUNT BOARD SPACERS

DWG. NO.
FW-XX-XX-XX-D-XXX-XXX-XX

BY: BRATCHER 11-03-1994 SHEET 3 OF 3