



3.3V CMOS OCTAL BUFFER/DRIVER WITH 3-STATE OUTPUTS, 5 VOLT TOLERANT I/O

IDT74LVC240A ADVANCE INFORMATION

FEATURES:

- 0.5 MICRON CMOS Technology
- ESD > 2000V per MIL-STD-883, Method 3015;
> 200V using machine model (C = 200pF, R = 0)
- 1.27mm pitch SOIC, 0.65mm pitch SSOP,
0.635mm pitch QSOP, 0.65mm pitch TSSOP packages
- Extended commercial range of -40°C to +85°C
- Vcc = 3.3V ±0.3V, Normal Range
- Vcc = 2.3V to 3.6V, Extended Range
- CMOS power levels (0.4µW typ. static)
- Rail-to-Rail output swing for increased noise margin
- All inputs, outputs and I/O are 5 Volt tolerant
- Supports hot insertion

Drive Features for LVC240A:

- High Output Drivers: ±24mA
- Reduced system switching noise

APPLICATIONS:

- 5V and 3.3V mixed voltage systems
- Data communication and telecommunication systems

DESCRIPTION:

The LVC240A device is designed specifically to improve the performance and density of 3-state memory address drivers, clock drivers, and bus-oriented receivers and transmitters.

This device is organized as two 4-bit buffers/drivers with separate output-enable (\overline{OE}) inputs. When \overline{OE} is low, the device passes data from the A inputs to the Y outputs. When \overline{OE} is high, the outputs are in the high-impedance state.

The LVC240A has been designed with a ±24mA output driver. This driver is capable of driving a moderate to heavy load while maintaining speed performance.

To ensure the high-impedance state during power up or power down, \overline{OE} should be tied to Vcc through a pullup resistor; the minimum value of the resistor is determined by the current-sinking capability of the driver.

Inputs can be driven from either 3.3V or 5V devices. This feature allows the use of this device as a translator in a mixed 3.3V/5V system environment.

Functional Block Diagram

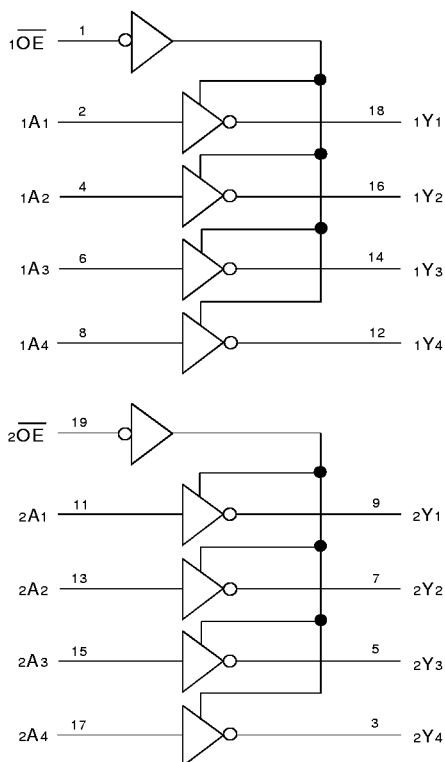

EXTENDED COMMERCIAL TEMPERATURE RANGE

APRIL 1999

PIN CONFIGURATION

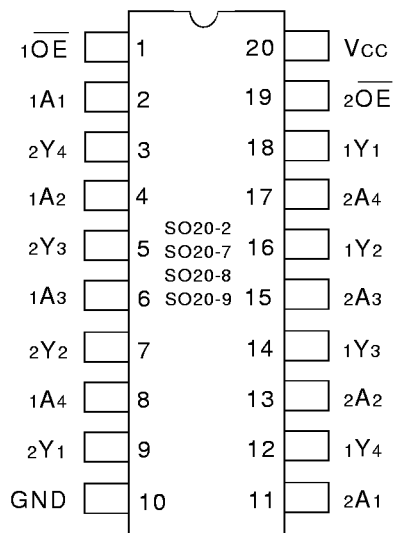

SOIC/ SSOP/ QSOP/ TSSOP
TOP VIEW

ABSOLUTE MAXIMUM RATINGS (1)

Symbol	Description	Max.	Unit
VTERM(2)	Terminal Voltage with Respect to GND	- 0.5 to +6.5	V
VTERM(3)	Terminal Voltage with Respect to GND	- 0.5 to +6.5	V
TSTG	Storage Temperature	- 65 to +150	°C
IOUT	DC Output Current	- 50 to +50	mA
I _{IK}	Continuous Clamp Current, V _I < 0 or V _O < 0	- 50	mA
I _{CC}	Continuous Current through each V _{CC} or GND	±100	mA

NOTES:

- Stresses greater than those listed under ABSOLUTE MAXIMUM RATINGS may cause permanent damage to the device. This is a stress rating only and functional operation of the device at these or any other conditions above those indicated in the operational sections of this specification is not implied. Exposure to absolute maximum rating conditions for extended periods may affect reliability.
- V_{CC} terminals.
- All terminals except V_{CC}.

CAPACITANCE (T_A = +25°C, f = 1.0MHz)

Symbol	Parameter(1)	Conditions	Typ.	Max.	Unit
C _{IN}	Input Capacitance	V _{IN} = 0V	4.5	6	pF
C _{OUT}	Output Capacitance	V _{OUT} = 0V	5.5	8	pF
C _{I/O}	I/O Port Capacitance	V _{IN} = 0V	6.5	8	pF

NOTE:

- As applicable to the device type.

PIN DESCRIPTION

Pin Names	Description
x \overline{OE}	3-State Output-enable Inputs (Active LOW)
xAx	Data Inputs
xYx	Data Outputs

FUNCTION TABLE (each buffer) (1)

Inputs		Outputs
x \overline{OE}	xAx	xYx
L	H	L
L	L	H
H	X	Z

NOTE:

- H = HIGH Voltage Level
 L = LOW Voltage Level
 X = Don't Care
 Z = High-Impedance

DC ELECTRICAL CHARACTERISTICS OVER OPERATING RANGE

Following Conditions Apply Unless Otherwise Specified:

Operating Condition: $T_A = -40^\circ\text{C}$ To $+85^\circ\text{C}$

Symbol	Parameter	Test Conditions		Min.	Typ. ⁽¹⁾	Max.	Unit
V _{IH}	Input HIGH Voltage Level	V _{CC} = 2.3V to 2.7V		1.7	—	—	V
		V _{CC} = 2.7V to 3.6V		2	—	—	
V _{IL}	Input LOW Voltage Level	V _{CC} = 2.3V to 2.7V		—	—	0.7	V
		V _{CC} = 2.7V to 3.6V		—	—	0.8	
I _{IH} I _{IL}	Input Leakage Current	V _{CC} = 3.6V	V _I = 0 to 5.5V	—	—	±5	μA
IOZH IOZL	High Impedance Output Current (3-State Output pins)	V _{CC} = 3.6V	V _O = 0 to 5.5V	—	—	±10	μA
IOFF	Input/Output Power Off Leakage	V _{CC} = 0V, V _{IN} or V _O ≤ 5.5V		—	—	±50	μA
V _{IK}	Clamp Diode Voltage	V _{CC} = 2.3V, I _{IN} = -18mA		—	-0.7	-1.2	V
V _H	Input Hysteresis	V _{CC} = 3.3V		—	100	—	mV
ICCL ICCH ICCZ	Quiescent Power Supply Current	V _{CC} = 3.6V	V _{IN} = GND or V _{CC}	—	—	10	μA
			3.6 ≤ V _{IN} ≤ 5.5V ⁽²⁾	—	—	10	
ΔI _{CC}	Quiescent Power Supply Current Variation	One input at V _{CC} - 0.6V, other inputs at V _{CC} or GND		—	—	500	μA

8LVC Link

NOTES:

- Typical values are at V_{CC} = 3.3V, +25°C ambient.
- This applies in the disabled state only.

OUTPUT DRIVE CHARACTERISTICS

Symbol	Parameter	Test Conditions ⁽¹⁾		Min.	Max.	Unit
V _{OH}	Output HIGH Voltage	V _{CC} = 2.3V to 3.6V	I _{OH} = -0.1mA	V _{CC} - 0.2	—	V
		V _{CC} = 2.3V	I _{OH} = -6mA	2	—	
		V _{CC} = 2.3V	I _{OH} = -12mA	1.7	—	
		V _{CC} = 2.7V		2.2	—	
		V _{CC} = 3.0V		2.4	—	
		V _{CC} = 3.0V	I _{OH} = -24mA	2.2	—	
V _{OL}	Output LOW Voltage	V _{CC} = 2.3V to 3.6V	I _{OL} = 0.1mA	—	0.2	V
		V _{CC} = 2.3V	I _{OL} = 6mA	—	0.4	
			I _{OL} = 12mA	—	0.7	
		V _{CC} = 2.7V	I _{OL} = 12mA	—	0.4	
		V _{CC} = 3.0V	I _{OL} = 24mA	—	0.55	

8LVC Link

NOTE:

- V_{IH} and V_{IL} must be within the min. or max. range shown in the DC ELECTRICAL CHARACTERISTICS OVER OPERATING RANGE table for the appropriate V_{CC} range. $T_A = -40^\circ\text{C}$ to $+85^\circ\text{C}$.

OPERATING CHARACTERISTICS, $V_{CC} = 3.3V \pm 0.3V$, $T_A = 25^\circ C$

Symbol	Parameter	Test Conditions	Typical	Unit
CPD	Power Dissipation Capacitance per buffer/driver Outputs enabled	$C_L = 0pF$, $f = 10MHz$	32	pF
CPD	Power Dissipation Capacitance per buffer/driver Outputs disabled		3	pF

SWITCHING CHARACTERISTICS ⁽¹⁾

Symbol	Parameter	$V_{CC} = 2.5V \pm 0.2V$		$V_{CC} = 2.7V$		$V_{CC} = 3.3V \pm 0.3V$		Unit
		Min.	Max.	Min.	Max.	Min.	Max.	
tPLH tPHL	Propagation Delay xAx to xYx	—	—	—	7.5	1.3	6.5	ns
tpZH tpZL	Output Enable Time x \overline{OE} to xYx	—	—	—	9	1.1	8	ns
tpHZ tPLZ	Output Disable Time x \overline{OE} to xYx	—	—	—	8	1.4	7	ns
tsk(o)	Output Skew ⁽²⁾	—	—	—	—	—	1	ns

NOTES:

- See test circuits and waveforms. $T_A = -40^\circ C$ to $+85^\circ C$.
- Skew between any two outputs of the same package and switching in the same direction.

TEST CIRCUITS AND WAVEFORMS

TEST CONDITIONS

Symbol	V _{CC} (1) = 3.3V ± 0.3V	V _{CC} (1) = 2.7V	V _{CC} (2) = 2.5V ± 0.2V	Unit
V _{LOAD}	6	6	2 x V _{CC}	V
V _{IH}	2.7	2.7	V _{CC}	V
V _T	1.5	1.5	V _{CC} / 2	V
V _{LZ}	300	300	150	mV
V _{HZ}	300	300	150	mV
C _L	50	50	30	pF

8LVC Link

TEST CIRCUITS FOR ALL OUTPUTS

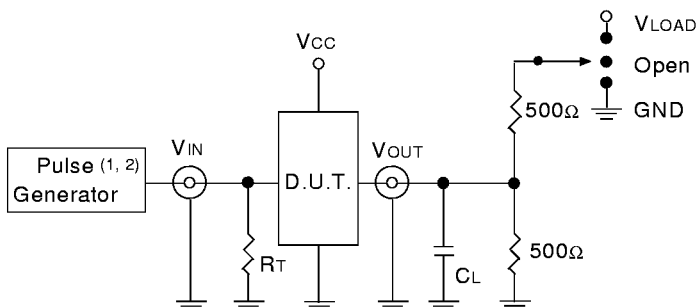

LVC Link

DEFINITIONS:

C_L = Load capacitance: includes jig and probe capacitance.
R_T = Termination resistance: should be equal to Z_{OUT} of the Pulse Generator.

NOTES:

1. Pulse Generator for All Pulses: Rate ≤ 10MHz; t_F ≤ 2.5ns; t_R ≤ 2.5ns.
2. Pulse Generator for All Pulses: Rate ≤ 10MHz; t_F ≤ 2ns; t_R ≤ 2ns.

SWITCH POSITION

Test	Switch
Open Drain	V _{LOAD}
Disable Low	
Enable Low	
Disable High	GND
Enable High	
All Other tests	Open

8LVC Link

OUTPUT SKEW - t_{SK}(x)

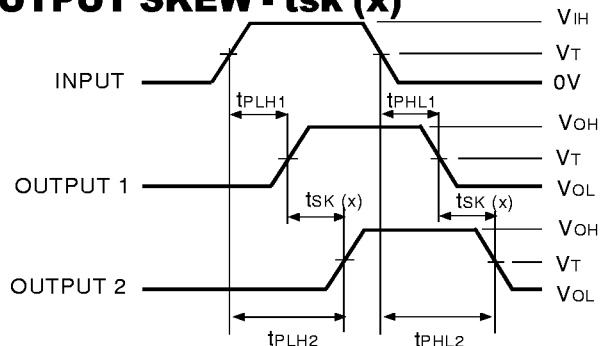

$$t_{SK}(x) = |t_{PLH2} - t_{PLH1}| \text{ or } |t_{PHL2} - t_{PHL1}|$$

LVC Link

NOTES:

1. For t_{SK}(o) OUTPUT1 and OUTPUT2 are any two outputs.
2. For t_{SK}(b) OUTPUT1 and OUTPUT2 are in the same bank.

PROPAGATION DELAY

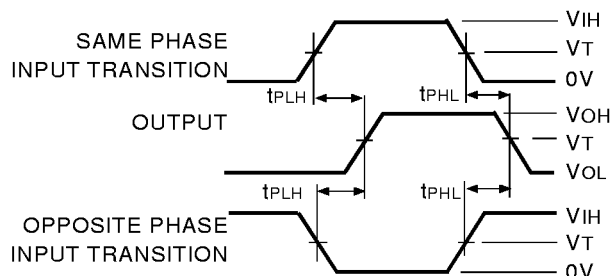

LVC Link

ENABLE AND DISABLE TIMES

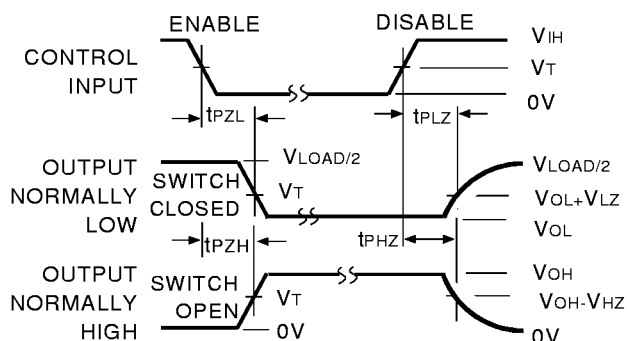

LVC Link

NOTE:

1. Diagram shown for input Control Enable-LOW and input Control Disable-HIGH.

SET-UP, HOLD, AND RELEASE TIMES

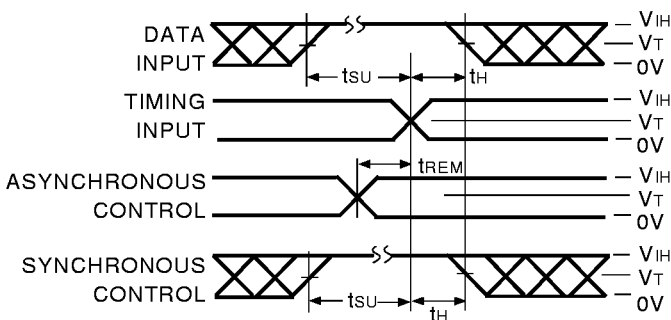

LVC Link

PULSE WIDTH

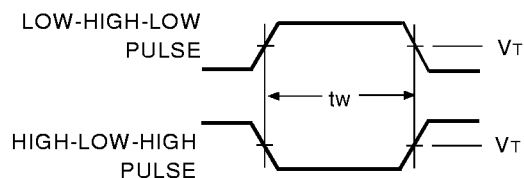

LVC Link

ORDERING INFORMATION

IDT	XX	LVC	X	XXXX	XX
Temp. Range	Bus-Hold	Device Type	Package		
				SO	Small Outline IC (gull wing) (SO20-2)
				PY	Shrink Small Outline Package (SO20-7)
				Q	Quarter Size Small Outline Package (SO20-8)
				PG	Thin Shrink Small Outline Package (SO20-9)
			240A		Octal Buffer/Driver with 3-State Outputs, ±24mA
		Blank			No Bus-hold
74					-40°C to +85°C

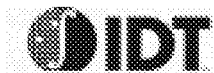

CORPORATE HEADQUARTERS
2975 Stender Way
Santa Clara, CA 95054

for SALES:
800-345-7015 or 408-727-6116
fax: 408-492-8674
www.idt.com*

**To search for sales office near you, please click the sales button found on our home page or dial the 800# above and press 2.
The IDT logo is a registered trademark of Integrated Device Technology, Inc.*