



# CD4023BM/CD4023BC Buffered Triple 3-Input NAND Gate

# CD4025BM/CD4025BC Buffered Triple 3-Input NOR Gate

### General Description

These triple gates are monolithic complementary MOS (CMOS) integrated circuits constructed with N- and P-channel enhancement mode transistors. They have equal source and sink current capabilities and conform to standard B series output drive. The devices also have buffered outputs which improve transfer characteristics by providing very high gain. All inputs are protected against static discharge with diodes to  $V_{DD}$  and  $V_{SS}$ .

### Features

- Wide supply voltage range 3.0V to 15V
- High noise immunity 0.45  $V_{DD}$  (typ.)
- Low power TTL compatibility fan out of 2 driving 74L or 1 driving 74LS
- 5V–10V–15V parametric ratings
- Symmetrical output characteristics
- Maximum input leakage 1  $\mu$ A at 15V over full temperature range

### Connection Diagrams

CD4023BM/CD4023BC  
Dual-In-Line Package

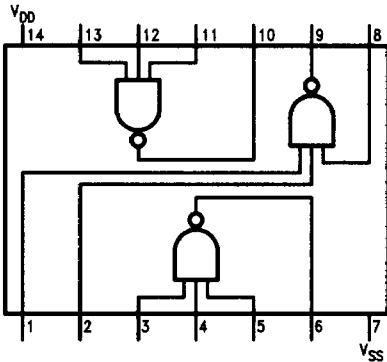

Top View

TL/F/5956-1

CD4025BM/CD4025BC  
Dual-In-Line Package

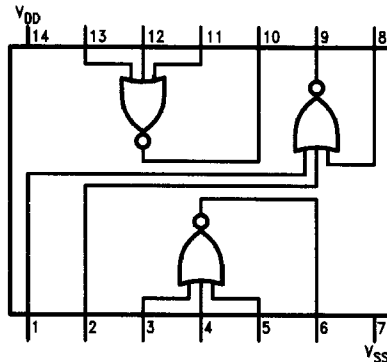

Top View

TL/F/5956-2

Order Number CD4023B\* or CD4025B\*

\*Please look into Section 8, Appendix D for availability of various package types.

### Absolute Maximum Ratings (Notes 1 & 2)

If Military/Aerospace specified devices are required, contact the National Semiconductor Sales Office/Distributors for availability and specifications.

DC Supply Voltage ( $V_{DD}$ )	-0.5 $V_{DC}$ to +18 $V_{DC}$
Input Voltage ( $V_{IN}$ )	-0.5 $V_{DC}$ to $V_{DD}$ + 0.5 $V_{DC}$
Storage Temp. Range ( $T_S$ )	-65°C to +150°C
Power Dissipation ( $P_D$ )	
Dual-In-Line	700 mW
Small Outline	500 mW
Lead Temperature ( $T_L$ )	
(Soldering, 10 seconds)	260°C

### Recommended Operating Conditions

DC Supply Voltage ( $V_{DD}$ )	5 $V_{DC}$ to 15 $V_{DC}$
Input Voltage ( $V_{IN}$ )	0 $V_{DC}$ to $V_{DD}$ $V_{DC}$
Operating Temperature Range ( $T_A$ )	
CD4023BM, CD4025BM	-55°C to +125°C
CD4023BC, CD4025BC	-40°C to +85°C

### DC Electrical Characteristics CD4023BM, CD4025BM (Note 2)

Symbol	Parameter	Conditions	-55°C		+25°C			+125°C		Units				
			Min	Typ	Min	Typ	Max	Min	Max					
$I_{DD}$	Quiescent Device Current	$V_{DD} = 5V$		0.25		0.004	0.25		7.5	$\mu A$				
		$V_{DD} = 10V$		0.5		0.005	0.5		15	$\mu A$				
		$V_{DD} = 15V$		1.0		0.006	1.0		30	$\mu A$				
$V_{OL}$	Low Level Output Voltage	$V_{DD} = 5V$		0.05		0	0.05		0.05	V				
		$V_{DD} = 10V$		0.05		0	0.05		0.05	V				
		$V_{DD} = 15V$		0.05		0	0.05		0.05	V				
$V_{OH}$	High Level Output Voltage	$V_{DD} = 5V$	4.95		4.95	5		4.95		V				
		$V_{DD} = 10V$	9.95		9.95	10		9.95		V				
		$V_{DD} = 15V$	14.95		14.95	15		14.95		V				
$V_{IL}$	Low Level Input Voltage	$V_{DD} = 5V, V_O = 4.5V$	}	$ I_O  < 1\mu A$		2	1.5		1.5	V				
		$V_{DD} = 10V, V_O = 9.0V$									3.0	4	3.0	3.0
		$V_{DD} = 15V, V_O = 13.5V$									4.0	6	4.0	4.0
$V_{IH}$	High Level Input Voltage	$V_{DD} = 5V, V_O = 0.5V$	}	$ I_O  < 1\mu A$		3	3.5		3.5	V				
		$V_{DD} = 10V, V_O = 1.0V$									7.0	6	7.0	7.0
		$V_{DD} = 15V, V_O = 1.5V$									11.0	9	11.0	11.0
$I_{OL}$	Low Level Output Current (Note 3)	$V_{DD} = 5V, V_O = 0.4V$	0.64		0.51	0.88		0.36		mA				
		$V_{DD} = 10V, V_O = 0.5V$	1.6		1.3	2.2		0.90		mA				
		$V_{DD} = 15V, V_O = 1.5V$	4.2		3.4	8		2.4		mA				
$I_{OH}$	High Level Output Current (Note 3)	$V_{DD} = 5V, V_O = 4.6V$	-0.64		-0.51	-0.88		-0.36		mA				
		$V_{DD} = 10V, V_O = 9.5V$	-1.6		-1.3	-2.2		-0.90		mA				
		$V_{DD} = 15V, V_O = 13.5V$	-4.2		-3.4	-8		-2.4		mA				
$I_{IN}$	Input Current	$V_{DD} = 15V, V_{IN} = 0V$		-0.10		$-10^{-5}$	-0.10		-1.0	$\mu A$				
		$V_{DD} = 15V, V_{IN} = 15V$		0.10		$10^{-5}$	0.10		1.0	$\mu A$				

### Schematic Diagram

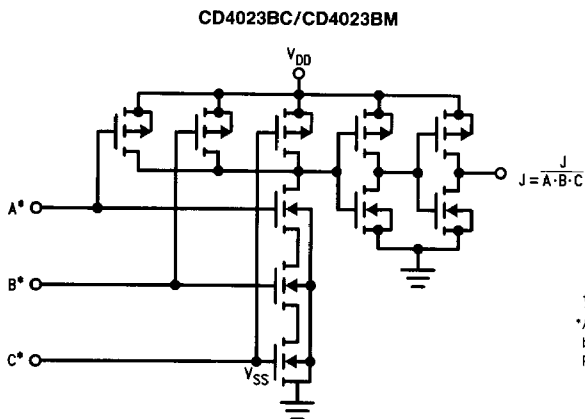

½ Device Shown  
 \*All Inputs Protected  
 by Standard CMOS Input  
 Protection Circuit.

TL/F/5956-3

## DC Electrical Characteristics CD4023BC, CD4025BC (Note 2)

Symbol	Parameter	Conditions	-40°C		+25°C			+85°C		Units
			Min	Typ	Min	Typ	Max	Min	Max	
I <sub>DD</sub>	Quiescent Device Current	V <sub>DD</sub> = 5V		1.0		0.004	1.0		7.5	μA
		V <sub>DD</sub> = 10V		2.0		0.005	2.0		15	μA
		V <sub>DD</sub> = 15V		4.0		0.006	4.0		30	μA
V <sub>OL</sub>	Low Level Output Voltage	V <sub>DD</sub> = 5V		0.05		0	0.05		0.05	V
		V <sub>DD</sub> = 10V		0.05		0	0.05		0.05	V
		V <sub>DD</sub> = 15V		0.05		0	0.05		0.05	V
V <sub>OH</sub>	High Level Output Voltage	V <sub>DD</sub> = 5V	4.95		4.95	5		4.95		V
		V <sub>DD</sub> = 10V	9.95		9.95	10		9.95		V
		V <sub>DD</sub> = 15V	14.95		14.95	15		14.95		V
V <sub>IL</sub>	Low Level Input Voltage	V <sub>DD</sub> = 5V, V <sub>O</sub> = 4.5V	}  I <sub>O</sub>   < 1μA	1.5		2	1.5		1.5	V
		V <sub>DD</sub> = 10V, V <sub>O</sub> = 9.0V		3.0		4	3.0		3.0	V
		V <sub>DD</sub> = 15V, V <sub>O</sub> = 13.5V		4.0		6	4.0		4.0	V
V <sub>IH</sub>	High Level Input Voltage	V <sub>DD</sub> = 5V, V <sub>O</sub> = 0.5V	}  I <sub>O</sub>   < 1μA	3.5		3			3.5	V
		V <sub>DD</sub> = 10V, V <sub>O</sub> = 1.0V		7.0		6			7.0	V
		V <sub>DD</sub> = 15V, V <sub>O</sub> = 1.5V		11.0		9			11.0	V
I <sub>OL</sub>	Low Level Output Current (Note 3)	V <sub>DD</sub> = 5V, V <sub>O</sub> = 0.4V	0.52		0.44	0.88		0.36		mA
		V <sub>DD</sub> = 10V, V <sub>O</sub> = 0.5V	1.3		1.1	2.2		0.90		mA
		V <sub>DD</sub> = 15V, V <sub>O</sub> = 1.5V	3.6		3.0	8		2.4		mA
I <sub>OH</sub>	High Level Output Current (Note 3)	V <sub>DD</sub> = 5V, V <sub>O</sub> = 4.6V	-0.52		-0.44	-0.88		-0.36		mA
		V <sub>DD</sub> = 10V, V <sub>O</sub> = 9.5V	-1.3		-1.1	-2.2		-0.90		mA
		V <sub>DD</sub> = 15V, V <sub>O</sub> = 13.5V	-3.6		-3.0	-8		-2.4		mA
I <sub>IN</sub>	Input Current	V <sub>DD</sub> = 15V, V <sub>IN</sub> = 0V		-0.3		-10 <sup>-5</sup>	-0.3		-1.0	μA
		V <sub>DD</sub> = 15V, V <sub>IN</sub> = 15V		0.3		10 <sup>-5</sup>	0.3		1.0	μA

**Note 1:** "Absolute Maximum Ratings" are those values beyond which the safety of the device cannot be guaranteed; they are not meant to imply that the devices should be operated at these limits. The table of "Recommended Operating Conditions" and "Electrical Characteristics" provides conditions for actual device operation.

**Note 2:** V<sub>SS</sub> = 0V unless otherwise specified.

**Note 3:** I<sub>OH</sub> and I<sub>OL</sub> are tested one output at a time.

## Schematic Diagram

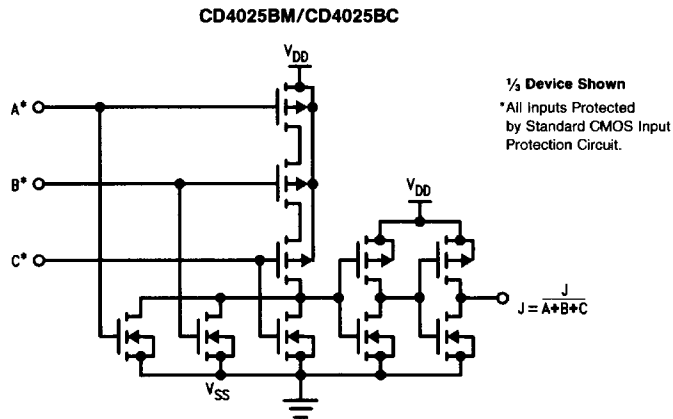

TL/F/5956-4

**AC Electrical Characteristics\***  $T_A = 25^\circ\text{C}$ ,  $C_L = 50\text{ pF}$ ,  $R_L = 200\text{ k}$ , unless otherwise specified

Symbol	Parameter	Conditions	CD4023BC CD4023BM			CD4025BC CD4025BM			Units
			Min	Typ	Max	Min	Typ	Max	
t <sub>PHL</sub>	Propagation Delay, High-to-Low Level	V <sub>DD</sub> = 5V		130	250		130	250	ns
		V <sub>DD</sub> = 10V		60	100		60	100	ns
		V <sub>DD</sub> = 15V		40	70		40	70	ns
t <sub>PLH</sub>	Propagation Delay, Low-to-High Level	V <sub>DD</sub> = 5V		110	250		120	250	ns
		V <sub>DD</sub> = 10V		50	100		60	100	ns
		V <sub>DD</sub> = 15V		35	70		40	70	ns
t <sub>THL</sub> t <sub>TLH</sub>	Transition Time	V <sub>DD</sub> = 5V		90	200		90	200	ns
		V <sub>DD</sub> = 10V		50	100		50	100	ns
		V <sub>DD</sub> = 15V		40	80		40	80	ns
C <sub>IN</sub>	Average Input Capacitance	Any Input		5	7.5		5	7.5	pF
C <sub>PD</sub>	Power Dissipation Capacity (Note 4)	Any Gate		17			17		pF

\*AC Parameters are guaranteed by DC correlated testing.

**Note 4:** C<sub>PD</sub> determines the no load AC power consumption of any CMOS device. For complete explanation, see 54C/74C Family Characteristics Application Note AN-90.