

54ACT/74ACT825 8-Bit D Flip-Flop

General Description

The 'ACT825 is an 8-bit buffered register. They have Clock Enable and Clear features which are ideal for parity bus interfacing in high performance microprogramming systems. Also included are multiple enables that allow multi-use control of the interface. The 'ACT825 has noninverting outputs and is fully compatible with AMD's Am29825.

Features

- Outputs source/sink 24 mA
- Inputs and outputs are on opposite sides
- 'ACT825 has TTL-compatible inputs
- Standard Military Drawing (SMD)
 - 'ACT825: 5962-91611

Logic Symbols

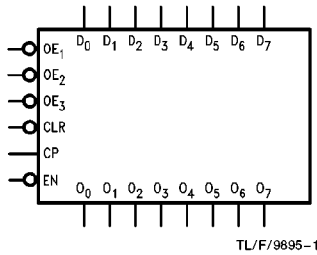

TL/F/9895-1

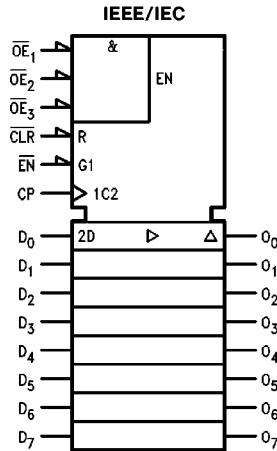

TL/F/9895-3

Connection Diagrams

Pin Assignment
for DIP, Flatpak and SOIC

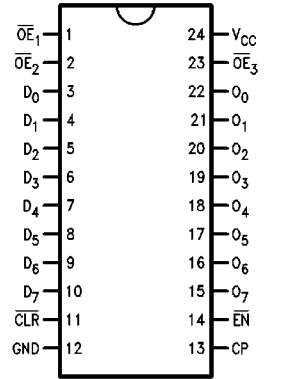

TL/F/9895-2

Pin Assignment
for LCC

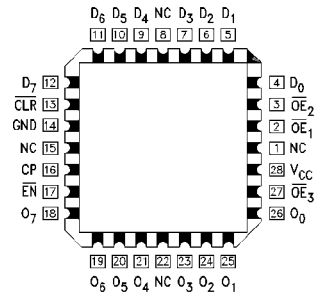

TL/F/9895-4

Pin Names	Description
D ₀ -D ₇	Data Inputs
O ₀ -O ₇	Data Outputs
$\overline{OE}_1, \overline{OE}_2, \overline{OE}_3$	Output Enables
\overline{EN}	Clock Enable
\overline{CLR}	Clear
CP	Clock Input

FACT™ is a trademark of National Semiconductor.
TRI-STATE® is a registered trademark of National Semiconductor Corporation.

Functional Description

The 'ACT825 consists of eight D-type edge-triggered flip-flops. These devices have TRI-STATE® outputs for bus systems, organized in a broadside pinning. In addition to the clock and output enable pins, the buffered clock (CP) and buffered Output Enable (\overline{OE}) are common to all flip-flops. The flip-flops will store the state of their individual D inputs that meet the setup and hold time requirements on the LOW-to-HIGH CP transition. With \overline{OE}_1 , \overline{OE}_2 and \overline{OE}_3 LOW, the contents of the flip-flops are available at the outputs. When one of \overline{OE}_1 , \overline{OE}_2 or \overline{OE}_3 is HIGH, the outputs go to the high impedance state.

Operation of the \overline{OE} input does not affect the state of the flip-flops. The 'ACT825 has Clear (\overline{CLR}) and Clock Enable (\overline{EN}) pins. These pins are ideal for parity bus interfacing in high performance systems.

When \overline{CLR} is LOW and \overline{OE} is LOW, the outputs are LOW. When \overline{CLR} is HIGH, data can be entered into the flip-flops. When \overline{EN} is LOW, data on the inputs is transferred to the outputs on the LOW-to-HIGH clock transition. When \overline{EN} is HIGH, the outputs do not change state, regardless of the data or clock input transitions.

Function Table

Inputs					Internal	Output	Function
\overline{OE}	\overline{CLR}	\overline{EN}	CP	D_n	Q	O	
H	X	L	↗	L	L	Z	High-Z
H	X	L	↗	H	H	Z	High-Z
H	L	X	X	X	L	Z	Clear
L	L	X	X	X	L	L	Clear
H	H	H	X	X	NC	Z	Hold
L	H	H	X	X	NC	NC	Hold
H	H	L	↗	L	L	Z	Load
H	H	L	↗	H	H	Z	Load
L	H	L	↗	L	L	L	Load
L	H	L	↗	H	H	H	Load

H = HIGH Voltage Level
 L = LOW Voltage Level
 X = Immaterial
 Z = High Impedance
 ↗ = LOW-to-HIGH Transition
 NC = No Change

Logic Diagram

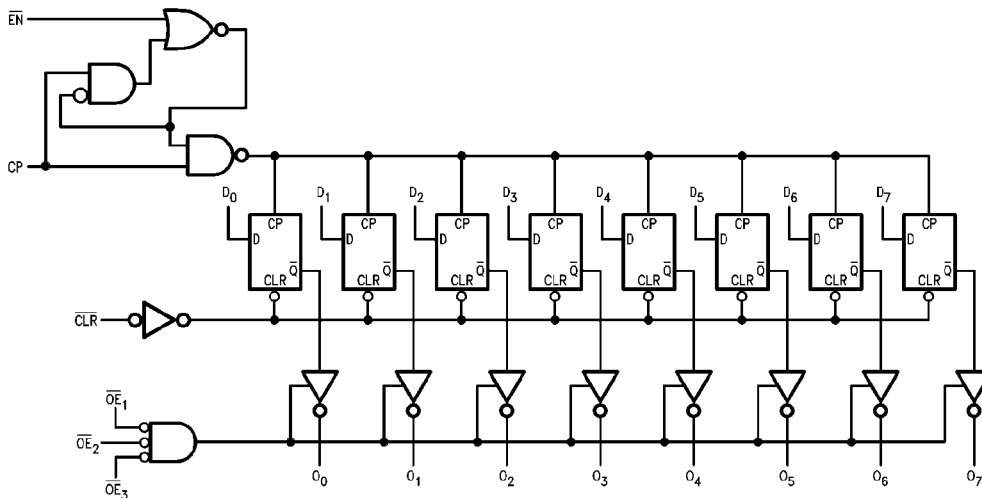

TL/F/9895-5

Please note that this diagram is provided only for the understanding of logic operations and should not be used to estimate propagation delays.

Absolute Maximum Ratings (Note 1)

If Military/Aerospace specified devices are required, please contact the National Semiconductor Sales Office/Distributors for availability and specifications.

Supply Voltage (V_{CC})	-0.5V to 7.0V
DC Input Diode Current (I_{IK})	
$V_I = -0.5V$	-20 mA
$V_I = V_{CC} + 0.5V$	+20 mA
DC Input Voltage (V_I)	-0.5V to $V_{CC} + 0.5V$
DC Output Diode Current (I_{OK})	
$V_O = -0.5V$	-20 mA
$V_O = V_{CC} + 0.5V$	+20 mA
DC Output Voltage (V_O)	+0.5V
DC Output Source or Sink Current (I_O)	±50 mA
DC V_{CC} or Ground Current	
Per Output Pin (I_{CC} or I_{GND})	±50 mA
Storage Temperature (T_{STG})	-65°C to +150°C
Junction Temperature (T_J)	
CDIP	175°C
PDIP	140°C

Note 1: Absolute maximum ratings are those values beyond which damage to the device may occur. The databook specifications should be met, without exception, to ensure that the system design is reliable over its power supply, temperature, and output/input loading variables. National does not recommend operation of FACT™ circuits outside databook specifications.

Recommended Operating Conditions

Supply Voltage (V_{CC})	4.5V to 5.5V
*ACT	
Input Voltage (V_I)	0V to V_{CC}
Output Voltage (V_O)	0V to V_{CC}
Operating Temperature (T_A)	
74ACT	-40°C to +85°C
54ACT	-55°C to +125°C
Minimum Input Edge Rate ($\Delta V/\Delta t$)	
*ACT Devices	
V_{IN} from 0.8V to 2.0V	
V_{CC} @ 4.5V, 5.5V	125 mV/ns

DC Electrical Characteristics

Symbol	Parameter	V_{CC} (V)	74ACT		54ACT		74ACT		Units	Conditions
			$T_A = 25^\circ\text{C}$		$T_A = -55^\circ\text{C to } +125^\circ\text{C}$		$T_A = -40^\circ\text{C to } +85^\circ\text{C}$			
			Typ	Guaranteed Limits						
V_{IH}	Minimum High Level Input Voltage	4.5	1.5	2.0	2.0		2.0		V	$V_{OUT} = 0.1V$ or $V_{CC} - 0.1V$
		5.5	1.5	2.0	2.0		2.0			
V_{IL}	Maximum Low Level Input Voltage	4.5	1.5	0.8	0.8		0.8		V	$V_{OUT} = 0.1V$ or $V_{CC} - 0.1V$
		5.5	1.5	0.8	0.8		0.8			
V_{OH}	Minimum High Level	4.5	4.49	4.4	4.4		4.4		V	$I_{OUT} = -50 \mu\text{A}$
		5.5	5.49	5.4	5.4		5.4			
		4.5		3.86	3.70		3.76		V	* $V_{IN} = V_{IL}$ or V_{IH} $I_{OH} = -24 \text{ mA}$ -24 mA
		5.5		4.86	4.70		4.76			
V_{OL}	Maximum Low Level Output Voltage	4.5	0.001	0.1	0.1		0.1		V	$I_{OUT} = 50 \mu\text{A}$
		5.5	0.001	0.1	0.1		0.1			
		4.5		0.36	0.50		0.44		V	* $V_{IN} = V_{IL}$ or V_{IH} $I_{OL} = 24 \text{ mA}$ 24 mA
		5.5		0.36	0.50		0.44			
I_{IN}	Maximum Input Leakage Current	5.5		±0.1	±1.0		±1.0		μA	$V_I = V_{CC}, \text{GND}$
I_{OZ}	Maximum TRI-STATE Current	5.5		±0.5	±10.0		±5.0		μA	$V_I = V_{IL}, V_{IH}$ $V_O = V_{CC}, \text{GND}$
I_{CCT}	Maximum I_{CC}/Input	5.5	0.6		1.6		1.5		mA	$V_I = V_{CC} - 2.1V$
I_{OLD}	†Minimum Dynamic	5.5			50		75		mA	$V_{OLD} = 1.65V \text{ Max}$
I_{OHD}	Output Current	5.5			-50		-75		mA	$V_{OHD} = 3.85V \text{ Min}$
I_{CC}	Maximum Quiescent Supply Current	5.5		8.0	160		80		μA	$V_{IN} = V_{CC}$ or GND

*All outputs loaded; thresholds on input associated with output under test.

†Maximum test duration 2.0 ms, one output loaded at a time.

Note: I_{CC} limit for 54ACT @ 25°C is identical to 74ACT @ 25°C.

AC Electrical Characteristics

Symbol	Parameter	V _{CC} * (V)	74ACT			54ACT		74ACT		Units
			T _A = +25°C C _L = 50 pF			T _A = -55°C to +125°C C _L = 50 pF		T _A = -40°C to +85°C C _L = 50 pF		
			Min	Typ	Max	Min	Max	Min	Max	
f _{max}	Maximum Clock Frequency	5.0	120	158		95		109	MHz	
t _{PLH}	Propagation Delay CP to O _n	5.0	1.5	5.5	9.5	1.5	11.5	1.5	10.5	ns
t _{PHL}	Propagation Delay CP to O _n	5.0	2.0	5.5	9.5	1.5	11.5	1.5	10.5	ns
t _{PHL}	Propagation Delay CLR to O _n	5.0	2.5	8.0	13.5	1.5	18.0	2.0	15.5	ns
t _{PZH}	Output Enable Time OE to O _n	5.0	1.5	6.0	10.5	1.5	11.5	1.5	11.5	ns
t _{PZL}	Output Enable Time OE to O _n	5.0	2.0	6.5	11.0	1.5	12.5	1.5	12.0	ns
t _{PHZ}	Output Disable Time OE to O _n	5.0	1.5	6.5	11.0	1.5	13.5	1.5	12.0	ns
t _{PLZ}	Output Disable Time OE to O _n	5.0	1.5	6.0	10.5	1.5	13.0	1.5	11.5	ns

*Voltage Range 5.0 is 5.0V ±0.5V

AC Operating Requirements

Symbol	Parameter	V _{CC} * (V)	74ACT		54ACT		74ACT		Units
			T _A = +25°C C _L = 50 pF		T _A = -55°C to +125°C C _L = 50 pF		T _A = -40°C to +85°C C _L = 50 pF		
			Typ	Guaranteed Minimum					
t _s	Setup Time, HIGH or LOW D _n to CP	5.0	0.5	2.5	4.0	2.5		ns	
t _h	Hold Time, HIGH or LOW D _n to CP	5.0	0	2.5	2.5	2.5		ns	
t _s	Setup Time, HIGH or LOW EN to CP	5.0	0	2.0	4.0	2.5		ns	
t _h	Hold Time, HIGH or LOW EN to CP	5.0	0	1.0	2.0	1.0		ns	
t _w	CP Pulse Width HIGH or LOW	5.0	2.5	4.5	6.0	5.5		ns	
t _w	CLR Pulse Width, LOW	5.0	3.0	5.5	7.0	5.5		ns	
t _{rec}	CLR to CP Recovery Time	5.0	1.5	3.5	4.5	4.0		ns	

*Voltage Range 5.0 is 5.0V ±0.5V

Capacitance

Symbol	Parameter	Typ	Units	Conditions
C _{IN}	Input Capacitance	4.5	pF	V _{CC} = OPEN
C _{PD}	Power Dissipation Capacitance	44	pF	V _{CC} = 5.0V

Ordering Information

The device number is used to form part of a simplified purchasing code where the package type and temperature range are defined as follows:

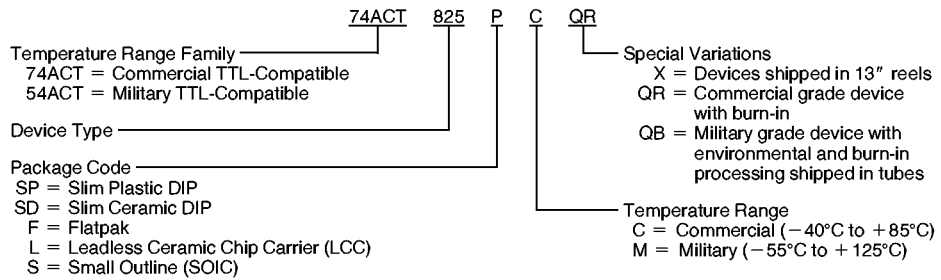

Physical Dimensions inches (millimeters)

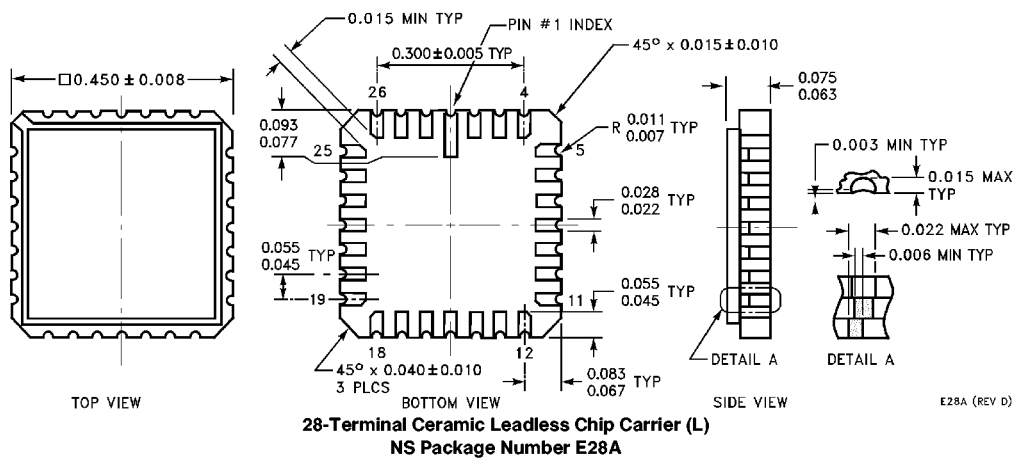

Physical Dimensions inches (millimeters) (Continued)

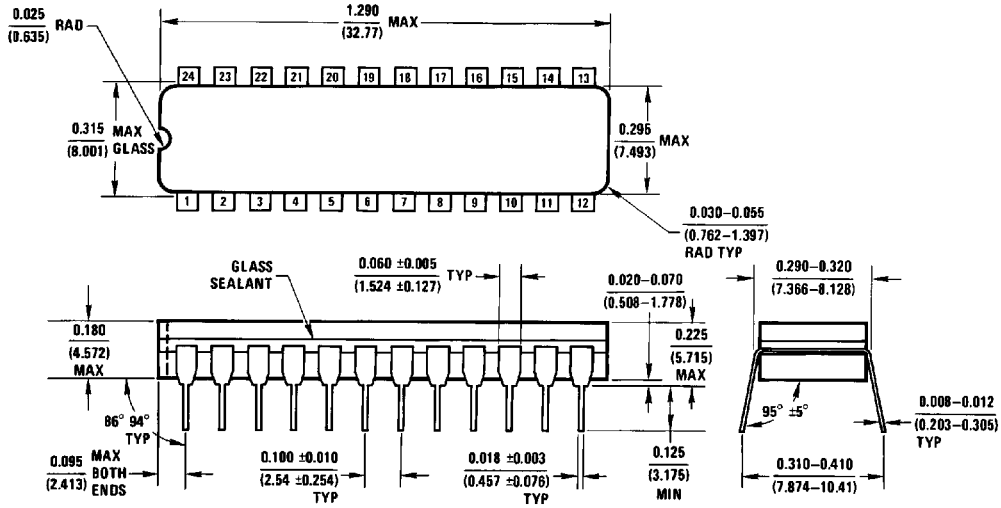

**24 Lead Slim (0.300" Wide) Ceramic Dual-In-Line (SD)
NS Package Number J24F**

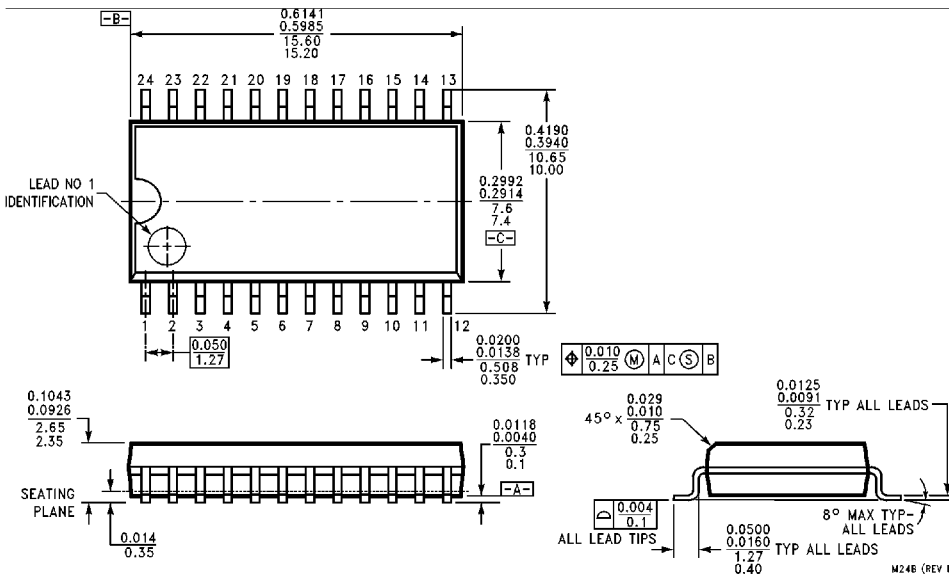

**24 Lead Small Outline Integrated Circuit (S)
NS Package Number M24B**

Physical Dimensions inches (millimeters) (Continued)

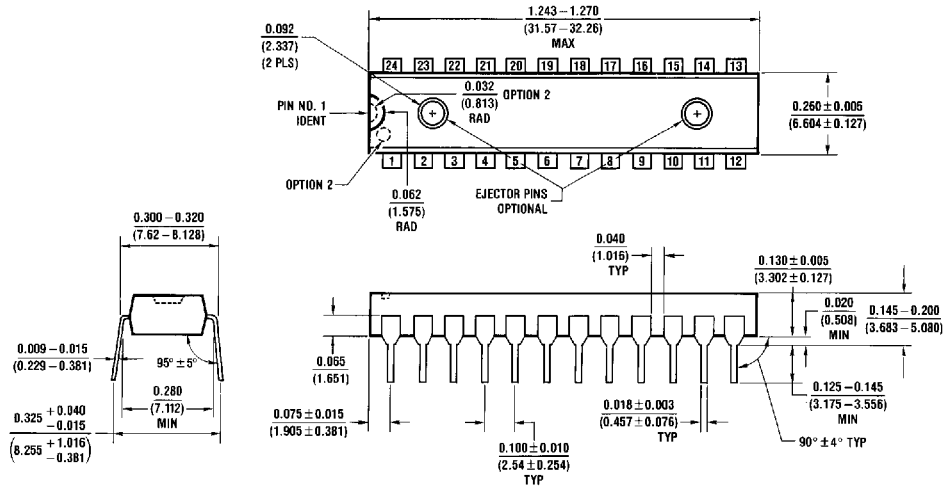

**24 Lead Slim (0.300" Wide) Plastic Dual-In-Line (SP)
NS Package Number N24C**

N24C (REV F)

Physical Dimensions inches (millimeters) (Continued)

Lit. # 114637

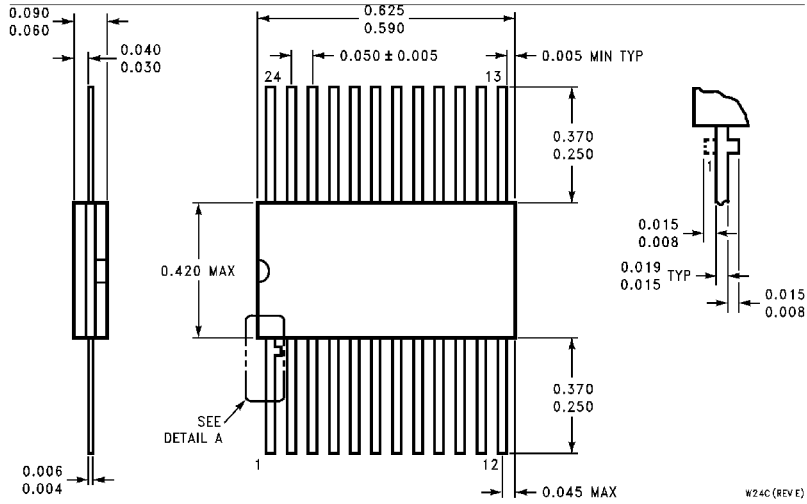

**24 Lead Ceramic Flatpak (F)
NS Package Number W24C**

LIFE SUPPORT POLICY

NATIONAL'S PRODUCTS ARE NOT AUTHORIZED FOR USE AS CRITICAL COMPONENTS IN LIFE SUPPORT DEVICES OR SYSTEMS WITHOUT THE EXPRESS WRITTEN APPROVAL OF THE PRESIDENT OF NATIONAL SEMICONDUCTOR CORPORATION. As used herein:

1. Life support devices or systems are devices or systems which, (a) are intended for surgical implant into the body, or (b) support or sustain life, and whose failure to perform, when properly used in accordance with instructions for use provided in the labeling, can be reasonably expected to result in a significant injury to the user.
2. A critical component is any component of a life support device or system whose failure to perform can be reasonably expected to cause the failure of the life support device or system, or to affect its safety or effectiveness.



National Semiconductor Corporation
2900 Semiconductor Drive
P.O. Box 58090
Santa Clara, CA 95052-8090
Tel: 1(800) 272-9959
TWX: (910) 339-9240

National Semiconductor GmbH
Livry-Gargan-Str. 10
D-82256 Fürstenfeldbruck
Germany
Tel: (81-41) 35-0
Telex: 527649
Fax: (81-41) 35-1

National Semiconductor Japan Ltd.
Sumitomo Chemical
Engineering Center
Bldg. 7F
1-7-1, Nakase, Mihama-Ku
Chiba-City,
Chiba Prefecture 261
Tel: (043) 299-2300
Fax: (043) 299-2500

National Semiconductor Hong Kong Ltd.
13th Floor, Straight Block,
Ocean Centre, 5 Canton Rd.
Tsimshatsui, Kowloon
Hong Kong
Tel: (852) 2737-1600
Fax: (852) 2736-9960

National Semicondutores Do Brazil Ltda.
Rue Deputado Lacorda Franco
120-3A
Sao Paulo-SP
Brazil 05418-000
Tel: (55-11) 212-5066
Telex: 391-1131931 NSBR BR
Fax: (55-11) 212-1181

National Semiconductor (Australia) Pty. Ltd.
Building 16
Business Park Drive
Monash Business Park
Nottingham, Melbourne
Victoria 3168 Australia
Tel: (3) 558-9999
Fax: (3) 558-9998

National does not assume any responsibility for use of any circuitry described, no circuit patent licenses are implied and National reserves the right at any time without notice to change said circuitry and specifications.