

COS/MOS INTEGRATED CIRCUIT

4028B

HCC/HCF 4028B

BCD-TO-DECIMAL DECODER

- BCD-TO-DECIMAL DECODING OR BINARY-TO-OCTAL DECODING
- HIGH DECODED OUTPUT DRIVE CAPABILITY
- "POSITIVE LOGIC" INPUTS AND OUTPUTS: DECODED OUTPUTS GO HIGH ON SELECTION
- MEDIUM-SPEED OPERATION: $t_{PHL}, t_{PLH} = 80 \text{ ns (TYP.) @ } V_{DD} = 10\text{V}$
- STANDARDIZED SYMMETRICAL OUTPUT CHARACTERISTICS
- QUIESCENT CURRENT SPECIFIED TO 20V FOR HCC DEVICE
- 5V, 10V, AND 15V PARAMETRIC RATINGS
- INPUT CURRENT OF 100 nA AT 18V AND 25°C FOR HCC DEVICE
- 100% TESTED FOR QUIESCENT CURRENT
- MEETS ALL REQUIREMENTS OF JEDEC TENTATIVE STANDARD No. 13A, "STANDARD SPECIFICATIONS FOR DESCRIPTION OF "B" SERIES CMOS DEVICES"

The **HCC 4028B** (extended temperature range) and **HCF 4028B** (intermediate temperature range) are monolithic integrated circuit, available in 16-lead dual in-line plastic or ceramic package, ceramic flat package and plastic micropackage.

The **HCC/HCF 4028B** types are BCD-to-decimal or binary-to-octal decoders consisting of buffering on all 4 inputs, decoding-logic gates, and 10 output buffers. A BCD code applied to the four inputs, A to D, results in a high level at the selected one of 10 decimal decoded outputs. Similarly, a 3-bit binary code applied to inputs A through C is decoded in octal code at output 0 to 7 if D = "0". High drive capability is provided at all outputs to enhance dc and dynamic performance in high fan-out applications.

ABSOLUTE MAXIMUM RATINGS

V_{DD}^*	Supply voltage: HCC types HCF types	-0.5 to 20	V
V_i	Input voltage	-0.5 to 18	V
I_i	DC input current (any one input)	-0.5 to $V_{DD} + 0.5$	V
P_{tot}	Total power dissipation (per package)	± 10	mA
	Dissipation per output transistor	200	mW
	for T_{op} = full package-temperature range	100	mW
T_{op}	Operating temperature: HCC types HCF types	-55 to 125	°C
		-40 to 85	°C
T_{stg}	Storage temperature	-65 to 150	°C

* All voltage values are referred to V_{SS} pin voltage

ORDERING NUMBERS:

- HCC 4028 BD for dual in-line ceramic package
- HCC 4028 BF for dual in-line ceramic package, frit seal
- HCC 4028 BK for ceramic flat package
- HCF 4028 BE for dual in-line plastic package
- HCF 4028 BF for dual in-line ceramic package, frit seal
- HCF 4028 BM for plastic micropackage

HCC/DCF 4028 B

MECHANICAL DATA (dimensions in mm)

Dual in-line ceramic package for HCC 4028 BD

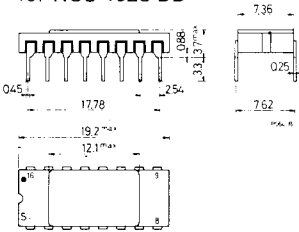

Dual in-line ceramic package for HCC/DCF 4028 BF

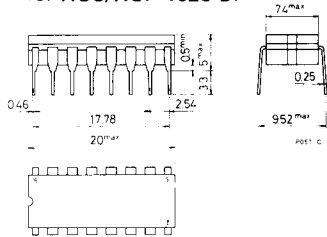

Dual in-line plastic package for HCF 4028 BE

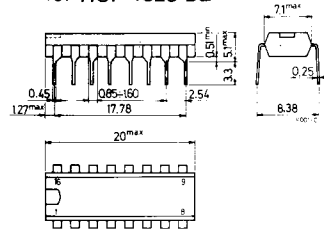

Ceramic flat package for HCC 4028 BK

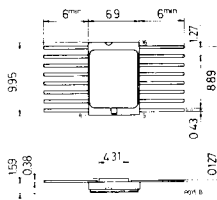

Plastic micropackage for HCF 4028 BM

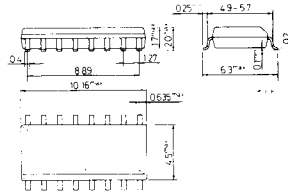

CONNECTION DIAGRAM

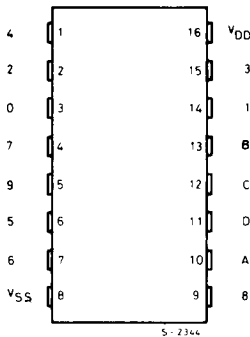

FUNCTIONAL DIAGRAM

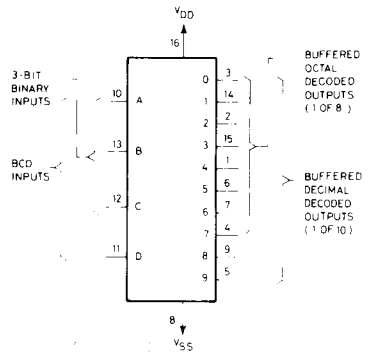

RECOMMENDED OPERATING CONDITIONS

V_{DD}	Supply voltage: HCC types HCF types	3 to 18 V 3 to 15 V	V
V_I	Input voltage	0 to V_{DD}	V
T_{op}	Operating temperature: HCC types HCF types	-55 to 125 °C -40 to 85 °C	°C

LOGIC DIAGRAM AND TRUTH TABLE

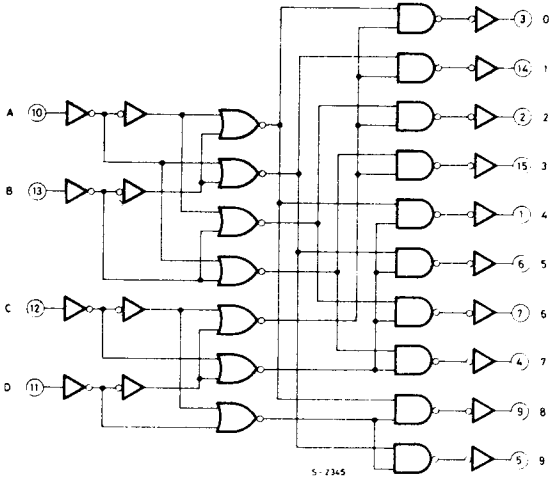

D	C	B	A	0	1	2	3	4	5	6	7	8	9
0	0	0	0	1	0	0	0	0	0	0	0	0	0
0	0	0	1	0	1	0	0	0	0	0	0	0	0
0	0	1	0	0	0	1	0	0	0	0	0	0	0
0	0	1	1	0	0	0	1	0	0	0	0	0	0
0	1	0	0	0	0	0	0	1	0	0	0	0	0
0	1	0	1	0	0	0	0	0	1	0	0	0	0
0	1	1	0	0	0	0	0	0	0	1	0	0	0
0	1	1	1	0	0	0	0	0	0	0	1	0	0
1	0	0	0	0	0	0	0	0	0	0	0	1	0
1	0	0	1	0	0	0	0	0	0	0	0	0	1
1	0	1	0	0	0	0	0	0	0	0	0	0	0
1	0	1	1	0	0	0	0	0	0	0	0	0	0
1	1	0	0	0	0	0	0	0	0	0	0	0	0
1	1	0	1	0	0	0	0	0	0	0	0	0	0
1	1	1	0	0	0	0	0	0	0	0	0	0	0
1	1	1	1	0	0	0	0	0	0	0	0	0	0

WHERE 1 = HIGH LEVEL
0 = LOW LEVEL

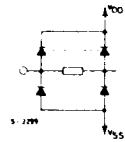

TEST CIRCUITS

Quiescent device current

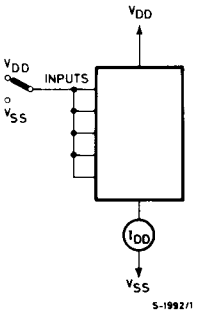

Noise immunity

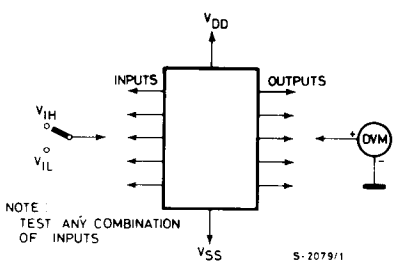

Input leakage current

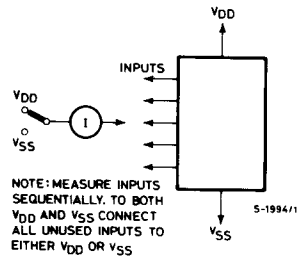

Dynamic power dissipation

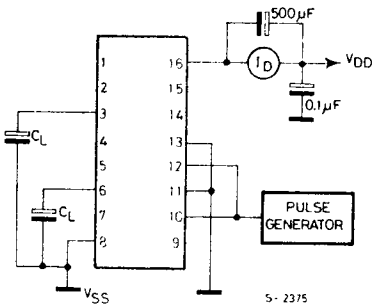

Typical transition time vs. load capacitance

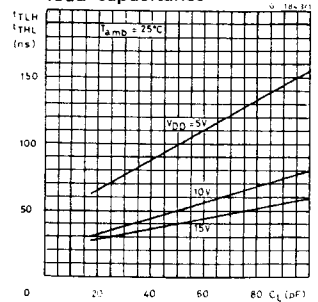

Comp
H_{CC} = 20
H_{CF} = 25
25 4/2/15 E

STATIC ELECTRICAL CHARACTERISTICS (under recommended operating conditions)

Parameter		Test conditions				Values						Unit		
		V _I (V)	V _O (V)	I _O (μA)	V _{DD} (V)	T _{Low} *		25°C			T _{High} *			
						Min.	Max.	Min.	Typ.	Max.	Min.		Max.	
I _L	Quiescent current	HCC types	0/ 5			5		5		0.04	5		150	μA
			0/10			10		10		0.04	10		300	
			0/15			15		20		0.04	20		600	
		HCF types	0/ 5			5		20		0.04	20		150	
			0/10			10		40		0.04	40		300	
			0/15			15		80		0.04	80		600	
V _{OH}	Output high voltage	0/ 5		< 1	5	4.95		4.95			4.95			V
		0/10		< 1	10	9.95		9.95			9.95			
		0/15		< 1	15	14.95		14.95			14.95			
V _{OL}	Output low voltage	5/0		< 1	5		0.05			0.05		0.05	V	
		10/0		< 1	10		0.05			0.05		0.05		
		15/0		< 1	15		0.05			0.05		0.05		
V _{IH}	Input high voltage		0.5/4.5	< 1	5	3.5		3.5			3.5		V	
			1/9	< 1	10	7		7			7			
			1.5/13.5	< 1	15	11		11			11			
V _{IL}	Input low voltage		4.5/0.5	< 1	5		1.5			1.5		1.5	V	
			9/1	< 1	10		3			3		3		
			13.5/1.5	< 1	15		4			4		4		
I _{OH}	Output drive current	HCC types	0/ 5	2.5		5	-2		-1.6	-3.2		-1.15	mA	
			0/ 5	4.6		5	-0.64		-0.51	-1		-0.36		
			0/10	9.5		10	-1.6		-1.3	-2.6		-0.9		
			0/15	13.5		15	-4.2		-3.4	-6.8		-2.4		
		HCF types	0/ 5	2.5		5	-1.53		-1.36	-3.2		-1.1		
			0/ 5	4.6		5	-0.52		-0.44	-1		-0.36		
I _{OL}	Output sink current	HCC types	0/ 5	0.4		5	0.64		0.51	1		0.36	mA	
			0/10	0.5		10	1.6		1.3	2.6		0.9		
			0/15	1.5		15	4.2		3.4	6.8		2.4		
		HCF types	0/ 5	0.4		5	0.52		0.44	1		0.36		
			0/10	0.5		10	1.3		1.1	2.6		0.9		
			0/15	1.5		15	3.6		3.0	6.8		2.4		
I _{IH} , I _{IL}	Input leakage current	HCC types	0/18	Any input	18		±0.1		±10 ⁻⁵	±0.1		± 1	μA	
		HCF types	0/15		15		±0.3		±10 ⁻⁵	±0.3		± 1		
C _I	Input capacitance			Any input					5	7.5			pF	

* T_{Low} = - 55°C for HCC device; -40°C for HCF device.
 * T_{High} = +125°C for HCC device; +85°C for HCF device.
 The Noise Margin for both "1" and "0" level is: 1V min. with V_{DD}= 5V
 2V min. with V_{DD}= 10V
 2.5V min. with V_{DD}= 15V

DYNAMIC ELECTRICAL CHARACTERISTICS ($T_{amb} = 25^{\circ}C$, $C_L = 50$ pF, $R_L = 200$ k Ω , typical temperature coefficient for all V_{DD} values is 0.3%/ $^{\circ}C$, all input rise and fall times = 20 ns)

Parameter	Test conditions	Values			Unit	
		V_{DD} (V)	Min.	Typ.		Max.
t_{PHL} , t_{PLH} Propagation delay time (Clock to "Out")		5		175	350	ns
		10		80	160	
		15		60	120	
t_{THL} , t_{TLH} Transition time		5		100	200	ns
		10		50	100	
		15		40	80	

Minimum output high (source) current characteristics

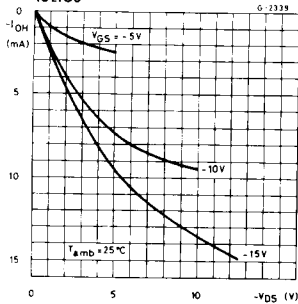

Typical output low (sink) current

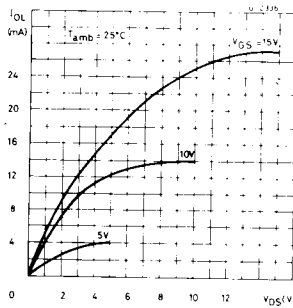

Minimum output low (sink) current characteristics

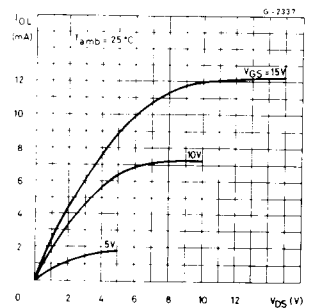

Typical output high (source) current characteristics

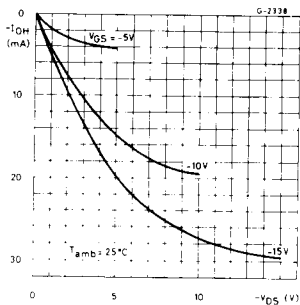

Typical propagation delay time as a function of load capacitance

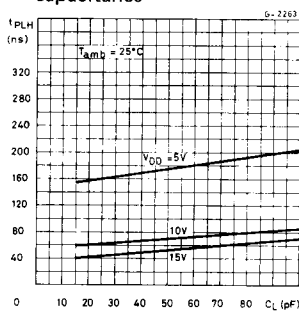

Typical dynamic power dissipation as a function of input frequency

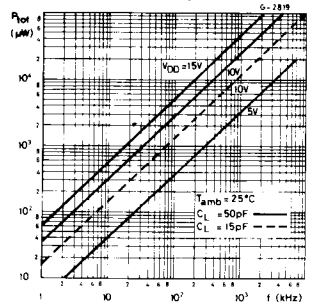

TYPICAL APPLICATIONS

The circuit shown in fig. 1 converts any 4-bit code to a decimal or hexadecimal code. Fig. 2 shows a number of codes and the decimal or hexadecimal number in these codes which must be applied to the input pins of the HCC/HCF 4028B to select a particular output. For example: in order to get a "high" on output n. 8 the input must be either an 8 expressed in 4-bit binary code, a 15 expressed in 4-bit Gray code, or a 5 expressed in Excess-3 code.

Fig. 1 - Code conversion circuit

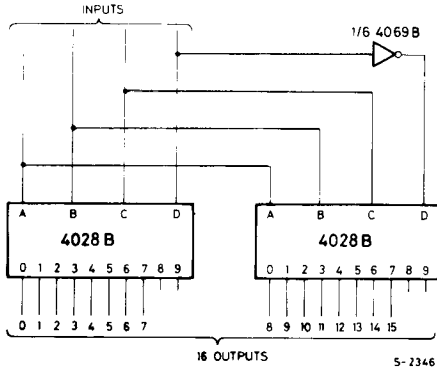

Fig. 2 - Code conversion chart

INPUTS	INPUT CODES				OUTPUT NUMBER
	Hexa-Decimal		Decimal		
	4 BIT BINARY	4 BIT GRAY	EXCESS 3	EXCESS 3 GRAY	
D C B A	4 BIT BINARY	4 BIT GRAY	EXCESS 3	EXCESS 3 GRAY	0 1 2 3 4 5 6 7 8 9 10 11 12 13 14 15
0 0 0 0	0 0	0 0	0 0	0 0	0 0 0 0 0 0 0 0 0 0 0 0 0 0 0 0
0 0 0 1	1 1	1 1	1 1	1 1	0 1 0 0 0 0 0 0 0 0 0 0 0 0 0 0
0 0 1 0	2 3	0 2	2 2	0 0	0 0 1 0 0 0 0 0 0 0 0 0 0 0 0 0
0 0 1 1	3 2	0 3	3 2	0 0	0 0 0 1 0 0 0 0 0 0 0 0 0 0 0 0
0 1 0 0	4 7	1 4	4 4	0 0	0 0 0 0 1 0 0 0 0 0 0 0 0 0 0 0
0 1 0 1	5 6	2 3	5 3	0 0	0 0 0 0 0 1 0 0 0 0 0 0 0 0 0 0
0 1 1 0	6 4	3 1	6 4	0 0	0 0 0 0 0 0 1 0 0 0 0 0 0 0 0 0
0 1 1 1	7 5	4 2	7 5	0 0	0 0 0 0 0 0 0 1 0 0 0 0 0 0 0 0
1 0 0 0	8 15	5 5	8 15	0 0	0 0 0 0 0 0 0 0 1 0 0 0 0 0 0 0
1 0 0 1	9 14	6 6	9 14	0 0	0 0 0 0 0 0 0 0 0 1 0 0 0 0 0 0
1 0 1 0	10 12	7 9	10 12	0 0	0 0 0 0 0 0 0 0 0 0 1 0 0 0 0 0
1 0 1 1	11 13	8 8	11 13	0 0	0 0 0 0 0 0 0 0 0 0 0 1 0 0 0 0
1 1 0 0	12 8	9 5	12 8	0 0	0 0 0 0 0 0 0 0 0 0 0 0 1 0 0 0
1 1 0 1	13 9	6 6	13 9	0 0	0 0 0 0 0 0 0 0 0 0 0 0 0 1 0 0
1 1 1 0	14 11	7 7	14 11	0 0	0 0 0 0 0 0 0 0 0 0 0 0 0 0 1 0
1 1 1 1	15 10	8 8	15 10	0 0	0 0 0 0 0 0 0 0 0 0 0 0 0 0 0 1

Fig. 4 - Neon readout (Nixie Tube) display application

Fig. 3 - 6-bit binary to 1 of 64 address decoder

