

**HiRel NPN Silicon Germanium RF Transistor**

- **HiRel Discrete and Microwave Semiconductor**
- High gain ultra low noise RF transistor
- Outstanding noise figure  $F = 0.7$  dB at 1.8 GHz  
Outstanding noise figure  $F = 1.0$  dB at 6 GHz
- Hermetically sealed microwave package

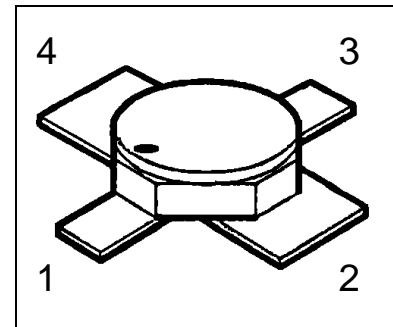

**ESD:** Electrostatic discharge sensitive device, observe handling precautions!

Type	Marking	Pin Configuration				Package
		1	2	3	4	
BFY740B	-	C	E	B	E	Micro-X

**Maximum Ratings**

Parameter	Symbol	Values	Unit
Collector-emitter voltage $T_a > 0$ °C $T_a \leq 0$ °C	$V_{CEO}$	4.0 3.5	V V
Collector-base voltage	$V_{CBO}$	13	V
Emitter-base voltage	$V_{EBO}$	1.2	V
Collector current <sup>1)</sup>	$I_C$	30	mA
Base current	$I_B$	3	mA
Junction temperature	$T_j$	175	°C
Operating temperature range	$T_{op}$	-65...+175	°C
Storage temperature range	$T_{stg}$	-65...+175	°C

**Thermal Resistance**

Junction-soldering point <sup>2)</sup>	$R_{thJS}$	400	K/W
--	------------	-----	-----

**Notes.:**

- 1) For  $T_S \leq 125$  °C. For  $T_S > 125$  °C derating is required.  
2)  $T_S$  is measured on the emitter lead at the soldering point to the pcb.

**Electrical Characteristics**

 at  $T_A=25^\circ\text{C}$ ; unless otherwise specified

Parameter	Symbol	Values			Unit
		min.	typ.	max.	
<b>DC Characteristics</b>					
Collector-base cutoff current $V_{CB} = 5\text{ V}, I_E = 0$	$I_{CBO}$	-	-	10	$\mu\text{A}$
Collector-emitter cutoff current <sup>1)</sup> $V_{CE} = 4.0\text{ V}, I_B = 0.1\ \mu\text{A}$	$I_{CEX}$	-	-	200	$\mu\text{A}$
Emitter-base cutoff current $V_{EB} = 1.2\text{ V}, I_C = 0$	$I_{EBO}$	-	-	5	$\mu\text{A}$
DC current gain $I_C = 20\text{ mA}, V_{CE} = 3\text{ V}$	$h_{FE}$	130	270	480	-
<b>AC Characteristics</b>					
Collector-base capacitance $V_{CB} = 2\text{ V}, V_{BE} = v_{be} = 0, f = 1\text{ MHz}$	$C_{CB}$	-	0.07	-	pF
Collector-emitter capacitance $V_{CE} = 2\text{ V}, V_{BE} = v_{be} = 0, f = 1\text{ MHz}$	$C_{CE}$	-	0.45	-	pF
Emitter-base capacitance $V_{EB} = 0.5\text{ V}, V_{CB} = v_{cb} = 0, f = 1\text{ MHz}$	$C_{EB}$	-	0.6	-	pF
Noise Figure ( $Z_S = Z_{s\text{opt}}$ ) $I_C = 8\text{ mA}, V_{CE} = 3\text{ V}, f = 1.8\text{ GHz}$ $I_C = 8\text{ mA}, V_{CE} = 3\text{ V}, f = 6.0\text{ GHz}$	F	-	0.7 1.0	-	dB
Insertion power gain ( $Z_S = Z_L = 50\ \Omega$ ) $I_C = 20\text{ mA}, V_{CE} = 3\text{ V}, f = 1.8\text{ GHz}$ $I_C = 20\text{ mA}, V_{CE} = 3\text{ V}, f = 6.0\text{ GHz}$	$ S_{21e} ^2$	-	24 14	-	dB
Power gain ( $Z_S = Z_{S\text{opt}}, Z_L = Z_{L\text{opt}}$ ) $I_C = 20\text{ mA}, V_{CE} = 3\text{ V}, f = 1.8\text{ GHz}$	$G_{ms}^{2)}$	-	26.5	-	dB
Power gain ( $Z_S = Z_{S\text{opt}}, Z_L = Z_{L\text{opt}}$ ) $I_C = 20\text{ mA}, V_{CE} = 3\text{ V}, f = 6.0\text{ GHz}$	$G_{ma}^{2)}$	-	18.3	-	dB

**Notes.:**

 1) This Test assures  $V(BR)CE0 > 4.0\text{ V}$ 

$$2) \quad G_{ma} = \left| \frac{S_{21}}{S_{12}} \right| (k - \sqrt{k^2 - 1}), \quad G_{ms} = \left| \frac{S_{21}}{S_{12}} \right|$$

## Micro-X Package

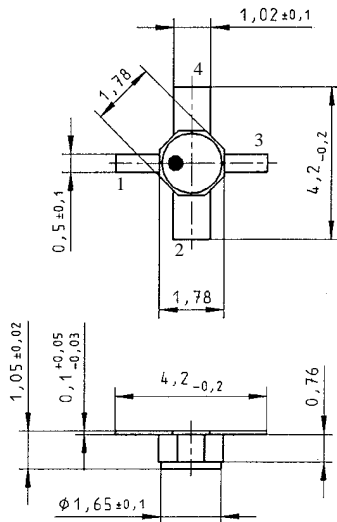

Edition 2011-08

Published by

Infineon Technologies AG

85579 Neubiberg, Germany

© Infineon Technologies AG 2011

All Rights Reserved.

### Attention please!

The information given in this document shall in no event be regarded as a guarantee of conditions or characteristics ("Beschaffenheitsgarantie"). With respect to any examples or hints given herein, any typical values stated herein and/or any information regarding the application of the device, Infineon Technologies hereby disclaims any and all warranties and liabilities of any kind, including without limitation warranties of non-infringement of intellectual property rights of a third party.

### Information

For further information on technology, delivery terms and conditions and prices please contact your nearest Infineon Technologies Office ([www.infineon.com](http://www.infineon.com)).

### Warnings

Due to technical requirements components may contain dangerous substances. For information on the types in question please contact your nearest Infineon Technologies Office.

Infineon Technologies Components may only be used in life-support devices or systems with the express written approval of Infineon Technologies, if a failure of such components can reasonably be expected to cause the failure of that life-support device or system, or to affect the safety or effectiveness of that device or system.

Life support devices or systems are intended to be implanted in the human body, or to support and/or maintain and sustain and/or protect human life. If they fail, it is reasonable to assume that the health of the user or other persons may be endangered.